

# FORD TRANSIT CONNECT



## UPFIT GUIDE

**RANGER**<sup>TM</sup>  
DESIGN

# Helping Mobile Technicians Work More Effectively by Providing Organized Storage Solutions

## At Ranger Design, we believe more is possible.

We believe work vehicles and the technicians that drive them can become more organized, more efficient, more productive and more profitable. At Ranger Design we're committed to bringing you the products and services that make that possible.

More means helping you choose the right work van for your

application, as well as giving you engineering support and expert advice to help design the most efficient work space in your new vehicle.

More also means getting that new van outfitted and on the road faster, so you can start using it for the reason you bought it.

We're committed to bringing you more, because we believe more is possible.



**MORE IS POSSIBLE**



## TABLE OF CONTENTS

CHOOSE A PRODUCT LINE .....	P. 4
PLAN YOUR VAN OUTFIT .....	P. 6
GETTING STARTED .....	P. 8
FLOORS .....	P. 10
PARTITIONS .....	P. 12
PACKAGES .....	P. 16
SHELVING .....	P. 34
DRAWERS .....	P. 39
ACCESSORIES .....	P. 48
LADDER RACKS .....	P. 58
INSTALL KITS .....	P. 60
INDEX .....	P. 61
HOW TO BUY .....	P. 62

# Choose A Product Line To Match Your Needs

Ranger Fleetline and Proline product groups ensure that fleets of any size have the best equipment to fit their budget, trade or fuel saving targets.



Ranger Fleetline

Ranger Proline

	<b>MATERIAL</b>	<b>BENEFITS</b>	<b>PRODUCTS</b>	<b>WARRANTY</b>
<b>WHY BUY RANGER FLEETLINE?</b> You want better quality and price than other steel products on the market.	Steel	Tough Low cost Quiet	Shelving, Partitions, Drawers, Accessories	3 years*
<b>WHY BUY RANGER PROLINE?</b> You want the toughest, quietest product on the market. You need to optimize payload without sacrificing quality.	Aluminum	<b>Toughest</b> <b>Lightweight</b> Quiet	<b>Shelving, Partitions,</b> <b>Drawers, Accessories,</b> <b>Ladder Racks</b>	<b>10 years*</b>

\*Ranger Design Inc. van equipment is warranted to be free from defects in material and workmanship under normal use and service for the period indicated, from the date of the original retail purchase, when installed per Ranger Design instructions in the original vehicle. Please contact Customer Service for full warranty details. Email: [cs@rangerdesign.com](mailto:cs@rangerdesign.com)

Throughout the catalog **FLEETLINE** products are depicted with yellow and **PROLINE** products with black.

**1-800-565-5321**  
7 A.M. – 8 P.M. EST

# World Class Customer Service



## Real people, ready to answer in 2 rings or less\*

We are pleased to offer efficient, personalized service and to answer all questions regarding:

- › Pricing/Quoting
- › Product install
- › Order status
- › Consultation
- › Shipment status
- › New product availability
- › Product specifications
- › Warranty claims
- › Returns/Restocking
- › Vehicle specifications

\*Call customer service and the phone will be answered in 2 rings or less. Yes, a real, live person working in one of our offices in North America is available to answer your questions. No automated attendant. No complicated phone tree and offshore service. Call us to experience the difference.

# PLAN YOUR VAN OUTFIT

## INSIDE ROOF HEIGHT

To determine the maximum shelf height that can be used in the van.

## PARTITION DEPTH

This indicates the space taken up by our partition for this vehicle. Please note that this measurement is determined by the partition that encroaches the most. Some partitions may take up less space. Take note that this measurement may not necessarily be on the floor.

## DOOR OPENING

To determine where shelving will land in relation to the door opening. Use this measurement to determine the space available for drawer units.

## DIMENSIONS IN RED

These dimensions indicate unique measurements for each wheelbase. Use red dimensions to determine the exact wheelbase of your van.

## FLOOR SPACE

This area is usable floor space but due to curvature of the van there may not be the same available area at the roof. Please measure actual van for specific measurement at roof.

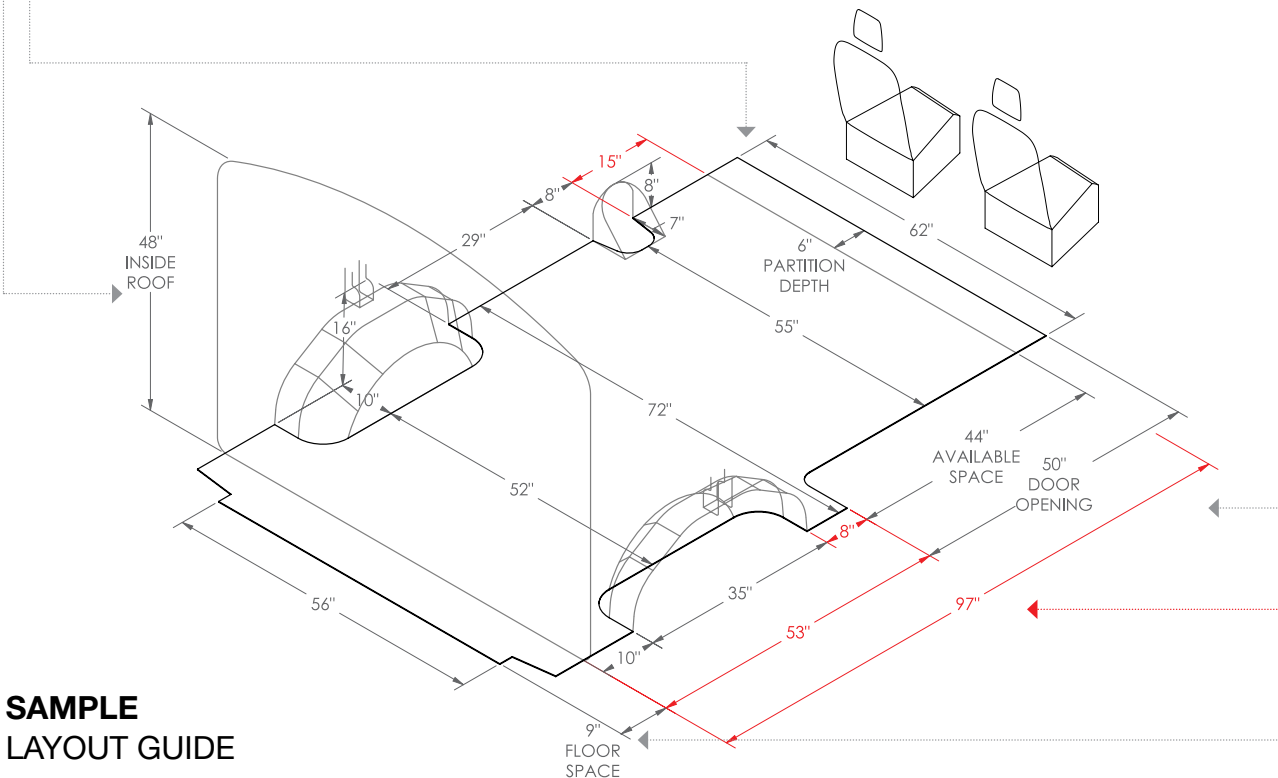

### SAMPLE LAYOUT GUIDE

Wheelbase

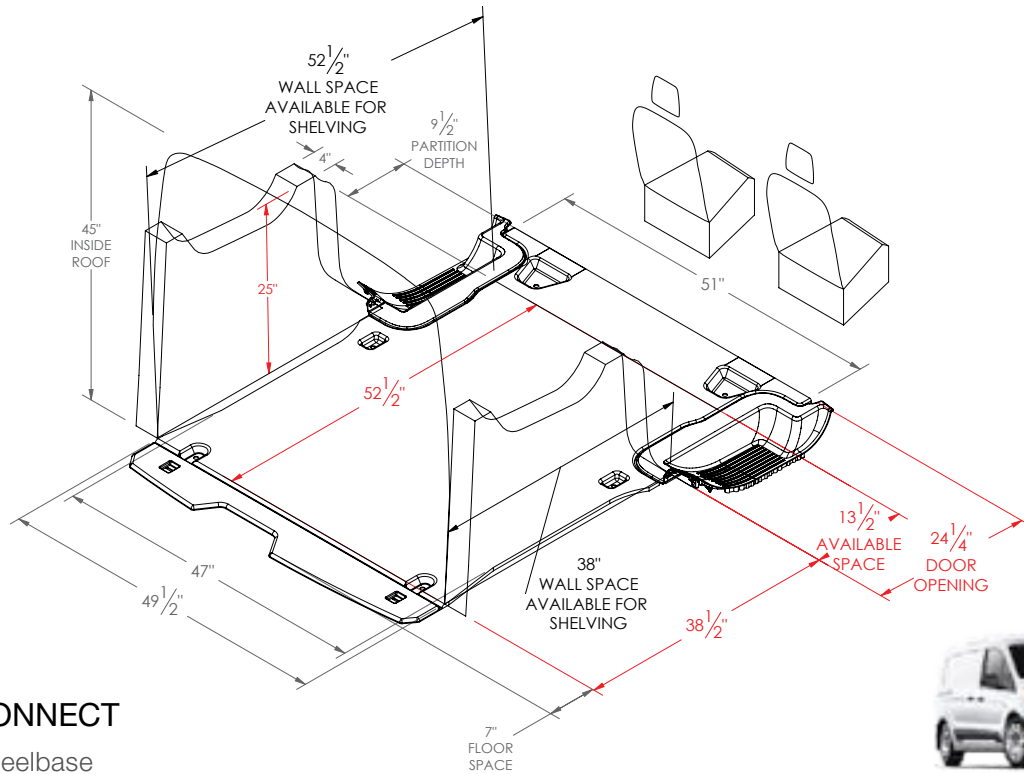

## FORD TRANSIT CONNECT

Short 105" Wheelbase  
Available in U.S. only

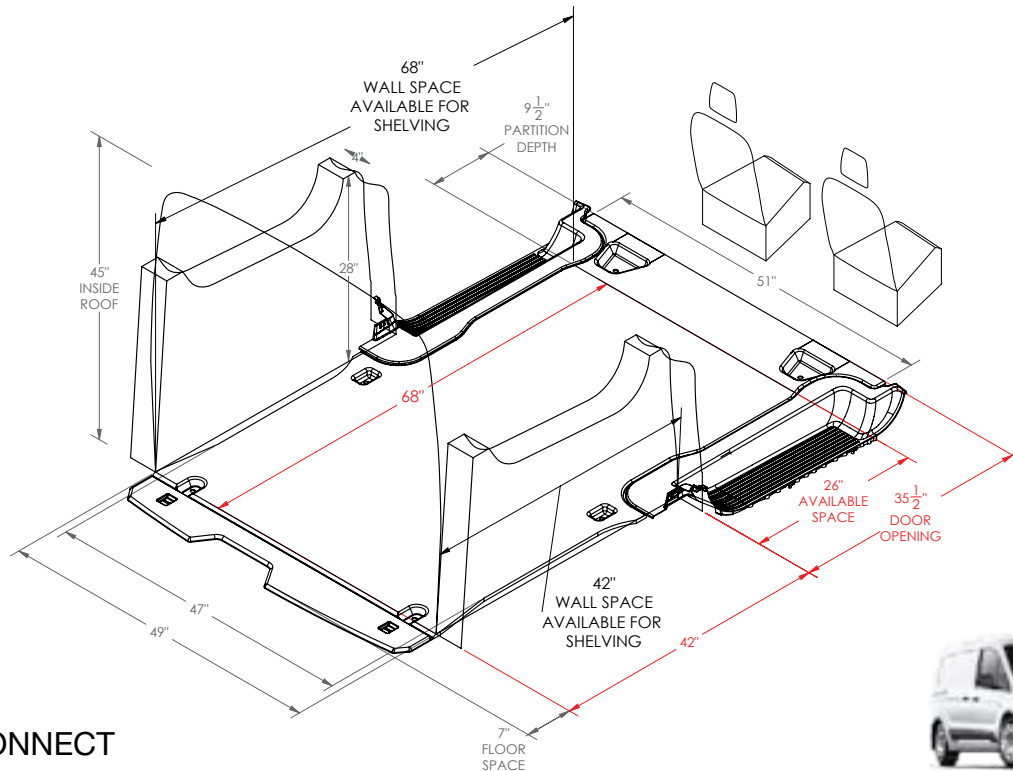

## FORD TRANSIT CONNECT

Long 120.5" Wheelbase

# Take a few minutes to write down these simple steps

## Plan your storage zones

For how long do you plan to use the vehicle?  A year  2–5 years  10 years or more (see page 4)

Will payload capacity be an issue?  Yes  No Why? \_\_\_\_\_

What type of industry are you in? \_\_\_\_\_

### What kind of partition do I need?

Do I need to see my cargo or see out the side doors?  Yes  No

Do I need the ability to go from the cabin to the cargo area through the partition?  Yes  No

### List the equipment/products you will need to store

Place the items that you need most often in the most accessible locations.

	How often will you use this?			Zone
	Daily	Weekly	Monthly	
_____	<input type="checkbox"/>	<input type="checkbox"/>	<input type="checkbox"/>	A-B-C-D-E
_____	<input type="checkbox"/>	<input type="checkbox"/>	<input type="checkbox"/>	_____
_____	<input type="checkbox"/>	<input type="checkbox"/>	<input type="checkbox"/>	_____
_____	<input type="checkbox"/>	<input type="checkbox"/>	<input type="checkbox"/>	_____
_____	<input type="checkbox"/>	<input type="checkbox"/>	<input type="checkbox"/>	_____

Will I need to carry larger objects  Yes  No

### List the tools you will need to carry

Place heavy tools closest to the access doors.

	How often will you use this?			Zone
	Daily	Weekly	Monthly	
_____	<input type="checkbox"/>	<input type="checkbox"/>	<input type="checkbox"/>	A-B-C-D-E
_____	<input type="checkbox"/>	<input type="checkbox"/>	<input type="checkbox"/>	_____
_____	<input type="checkbox"/>	<input type="checkbox"/>	<input type="checkbox"/>	_____
_____	<input type="checkbox"/>	<input type="checkbox"/>	<input type="checkbox"/>	_____
_____	<input type="checkbox"/>	<input type="checkbox"/>	<input type="checkbox"/>	_____

What kind of ladder(s) will I be carrying? Step ladder Extension ladders  
 Size \_\_\_\_\_ Size \_\_\_\_\_



# Storage Zones

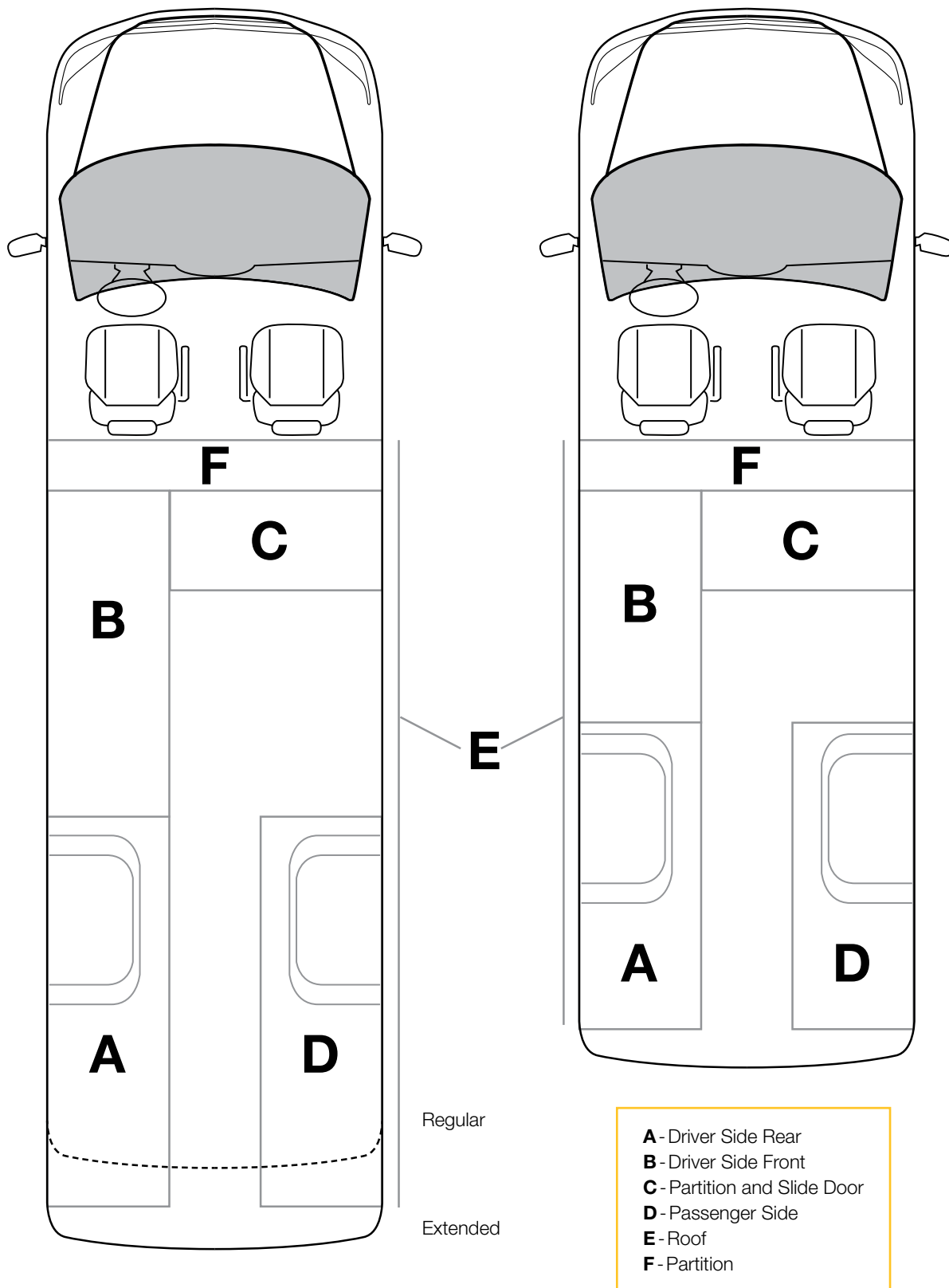

# IT'S MORE THAN A FLOOR

Ranger Design's unique flooring system with integrated aluminum mounting tracks provide a flush surface, making it easy to install a variety of Ranger Design shelving, equipment and accessories.

Ranger Designs' custom-fit rigid flooring system is available for every type of service van. Designed to provide added safety and quieter ride, these impact and puncture-resistant floors give your van a professional look.

Unique benefits of these flooring products include:

- › **Economical** – because the flooring has integrated mounting tracks for the price of a regular floor
- › **Safer** – due to the integrated track, improved load distribution and noise reduction
- › **Improved van resale value** – durable professional looking and protects the vehicle
- › **Efficient** – 3 panel floor installed in 45 minutes by one person and easy to maintain



## PROTECTION

The floor protects your vehicle and prevents damage to the factory floor.



## SAFETY

Due to the integrated track, improved load distribution and noise reduction.





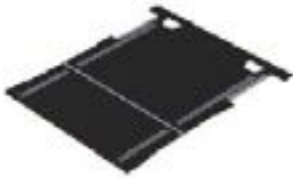

## EFFICIENCY

Custom-fit easy to install by one person.



### 6540-FCS





Ford Transit Connect Floor  
Short Wheelbase

	105"
	33 lbs
	1 hr
	Yes



### 6540-FCL

Ford Transit Connect Floor  
Long Wheelbase

	120.5"
	42 lbs
	1 hr
	Yes



Impact and puncture resistant floors preserve the cargo van interior.

# SAFETY PARTITIONS

Impact tested safety partitions protect the most important asset: you

Ranger Design safety partitions provide a solid and secure barrier between the occupants of the van and the cargo.

Built from heavy gauge steel, aluminum and thermoformed ABS and polycarbonate, they are designed for maximum impact resistance and uphold a standard of safety set only by Ranger Design products.

Ranger Design partitions also provide a more comfortable environment for the driver by giving more seat travel and by not rattling as the vehicle drives down the road.



## SAFE

Designed for maximum impact resistance. Proven by impact testing.



## EFFICIENT

1. Contoured to maintain seat travel and ensure driver comfort. 2. Contoured to capitalize on cargo area floor space.



## QUIET

Thickness of material cancels vibrations.



### 3010-TC

Contoured Safety Partition

**Aluminum**

Standard Roof

42 lbs

1 hr

Yes

9.25"

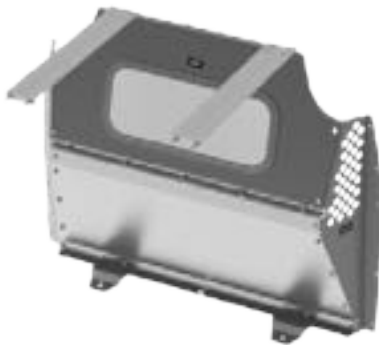

### 3020-TC

Contoured Safety Partition with Tempered Glass Window

**Aluminum**

Standard Roof

42 lbs

1 hr

Yes

9.25"



### 3320-TC

Max View Contoured Safety Partition

**Composite**

Standard Roof

51 lbs

0.7 hr

Yes

8.5"



### C10-E

Contoured Safety Partition with Perforated Window

**Steel**

Standard Roof

53 lbs

1 hr

Yes

9"

## SETBACK FROM B PILLAR

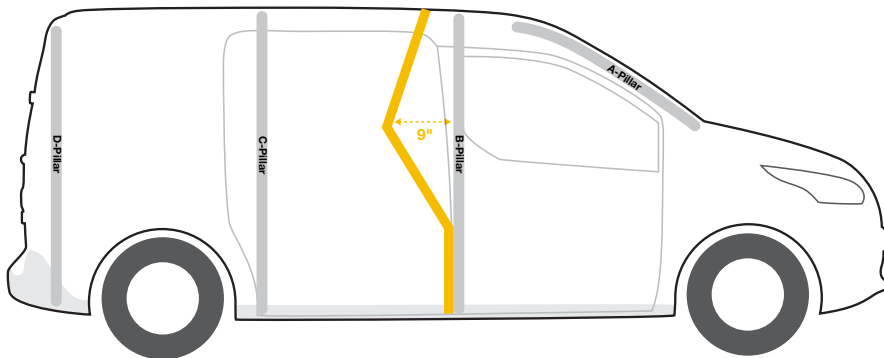

# SAFETY PARTITIONS

PARTITIONS



## C12-E

Contoured Safety Partition

### Steel

Standard Roof

53 lbs

1 hr

Yes

9"

## CONTOURED SAFETY PARTITIONS

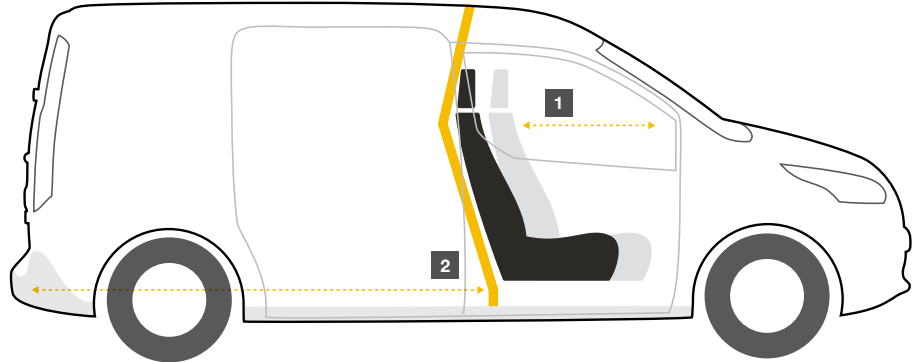

1. Contoured to maintain seat travel and ensure driver comfort.
2. Contoured to capitalize on cargo area floor space.



## C13-E

Wire Mesh Partition

### Steel

Standard Roof

27 lbs

0.7 hr

Yes

9"



**3020-TC** Contoured Safety Partition with Tempered Glass Window

SEE CLEARLY NOW, INTRODUCING THE REVOLUTIONARY

# MAX VIEW SAFETY PARTITION



WINNER OF

**THE  
WORK  
TRUCK  
SHOW.  
2016**

**2016  
INNOVATION  
AWARD**

The Ranger Design Max View gives you 180 degree rear visibility into the cargo area – giving you the safety and comfort you deserve

This state-of-the-art composite van partition provides unmatched protection with lightweight material. Built from thermoformed ABS and polycarbonate and is engineered to resist maximum impact. With a snug fit and rattle free construction it gives you:

- › Ergonomic cabin comfort
- › 180 degree rear visibility
- › Airtight climate control

More information on P.13

**THE PERFECT FIT**  
FOR YOUR TOUGHEST JOBS

**RANGER**<sup>TM</sup>  
DESIGN

*Our Promise: To Help You Work More Effectively by Providing Organized Storage Solutions.*



## **TRADE PACKAGES**

Pre-engineered packages  
for a broad range of trades.





**CHOICE**

A range of Fleetline and Proline packages are available for each vehicle.



**TRADE SPECIFIC**

Packages are created with the specific trades in mind. Optimized for maximum productivity.



**PERFECT FIT**

Engineered to optimize space. Layout designed to ensure that all tools are well within reach.

## TRADE PACKAGES

CONTRACTOR . . . . . P. 18  
DELIVERY . . . . . P. 30  
ELECTRICAL . . . . . P. 22  
SERVICE . . . . . P. 26

Get more out of your work van: Ranger Design packages are designed specifically with your trade in mind. Our aim is to ensure that your most frequently used tools and equipment are well within reach.

Do you see a way that we can improve our packages? We appreciate your feedback! Contact our customer service team at **1-800-565-5321**.





# Z10-C5

## Contractor Package

### **TOUGH**

Extrusion builds durability into shelf.

### **QUIET**

The combination of the extrusion, shelf tray, and end-panels create durable, vibration-free shelves.

### **EFFICIENT**

Ergonomic design reduces injuries and increases productivity.



\*Preproduction model shown,  
do not use as an installation guide.

# CONTRACTOR PACKAGES

PACKAGES

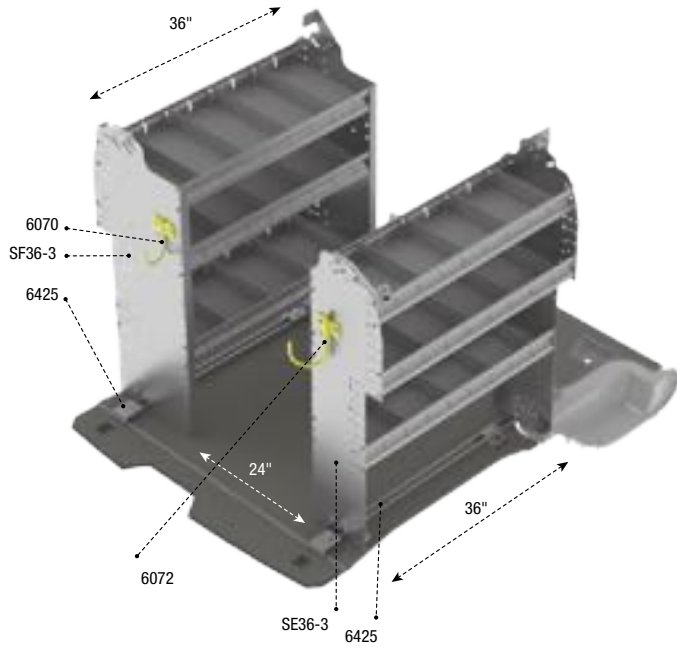

## C410

Contractor Package

**Aluminum**

105"

Standard

73 lbs

2.4 hrs

Yes

Qty	Part #	Description
1	6070	Large hook, fixed
1	6072	Large hook, swivel
2	6425	Shelf unit install kit
1	SE36-3	Shelf unit, contoured
1	SF36-3	Shelf unit, contoured

**Drill-free installation**

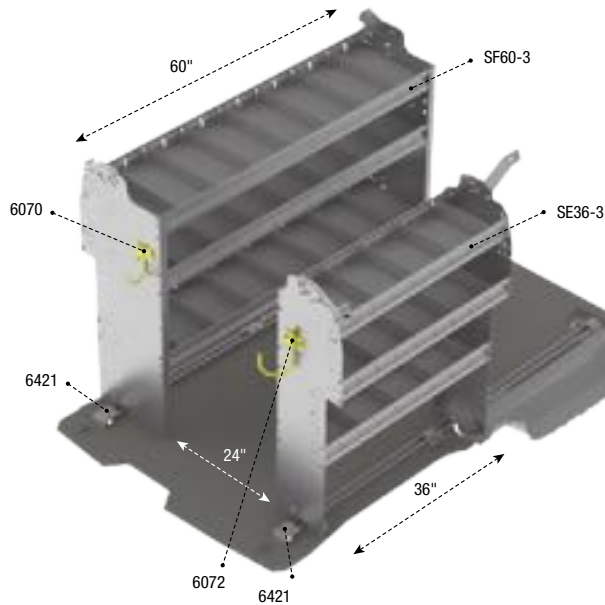

## C510

Contractor Package

**Aluminum**

120.5"

Standard

89 lbs

2.4 hrs

Yes

Qty	Part #	Description
1	6070	Large hook, fixed
1	6072	Large hook, swivel
2	6421	Shelf unit install kit
1	SE36-3	Shelf unit, contoured
1	SF60-3	Shelf unit, contoured

**Drill-free installation**

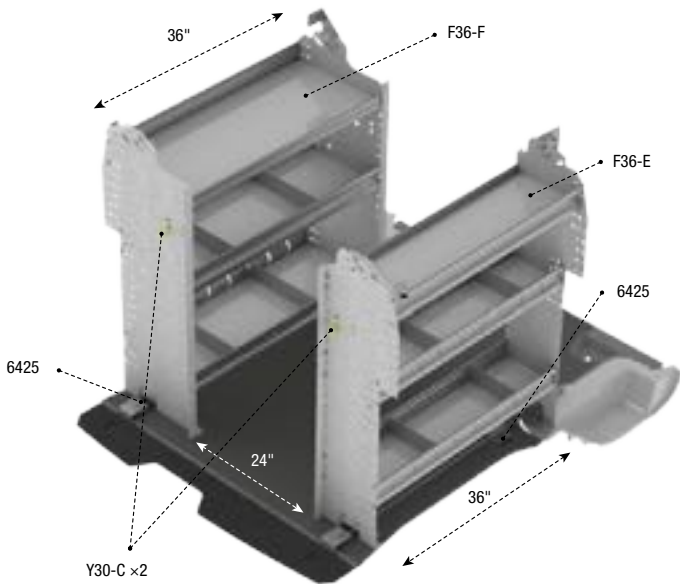

## Z10-C4 Base Contractor Package

**Steel**

105"	Standard	107 lbs
2.4 hrs	Yes	

Qty	Part #	Description
2	6425	Shelf unit install kit
1	F36-E	Shelf unit, contoured
1	F36-F	Shelf unit, contoured
2	Y30-C	Small hook

**Drill-free installation**

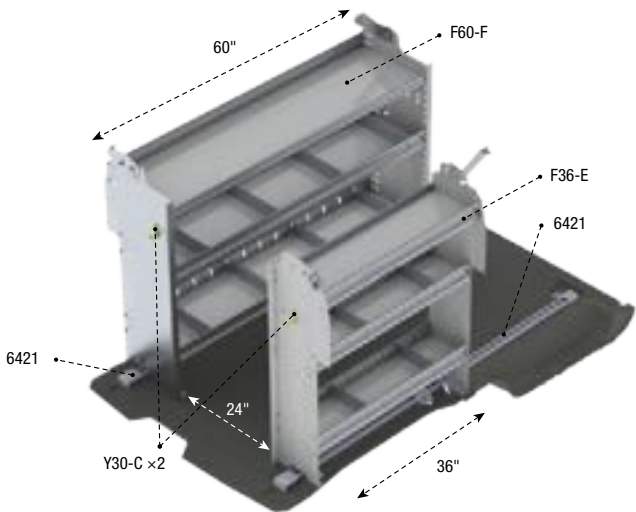

## Z10-C5 Base Contractor Package

**Steel**

120.5"	Standard	126 lbs
2.4 hrs	Yes	

Qty	Part #	Description
2	6421	Shelf unit install kit
1	F36-E	Shelf unit, contoured
1	F60-F	Shelf unit, contoured
2	Y30-C	Small hook

**Drill-free installation**



# C511

## Electrical Package

### **TOUGH**

Extrusion builds durability into shelf.

### **QUIET**

The combination of the extrusion, shelf tray, and end-panels create durable, vibration-free shelves.

### **EFFICIENT**

Ergonomic design reduces injuries and increases productivity.



\*Preproduction model shown,  
do not use as an installation guide.

# ELECTRICAL PACKAGES

PACKAGES

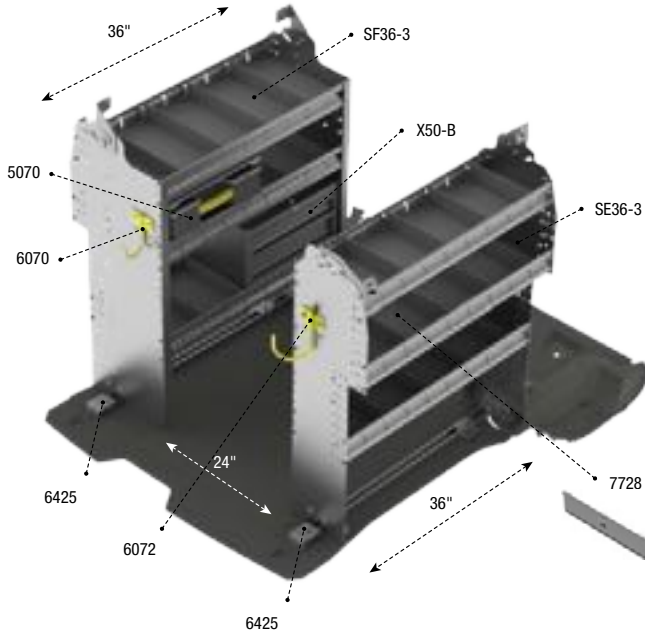

## C411 Electrical Package

**Aluminum**

105"

Standard

104 lbs

3.3 hrs

Yes

Qty	Part #	Description
1	5070	Partskeeper case with shelf mount holder
1	6070	Large hook, fixed
1	6072	Large hook, swivel
2	6425	Shelf unit install kit
1	7728	Locking door kit
1	SE36-3	Shelf unit, contoured
1	SF36-3	Shelf unit, contoured
1	X50-B	Drawer cabinet

**Drill-free installation**

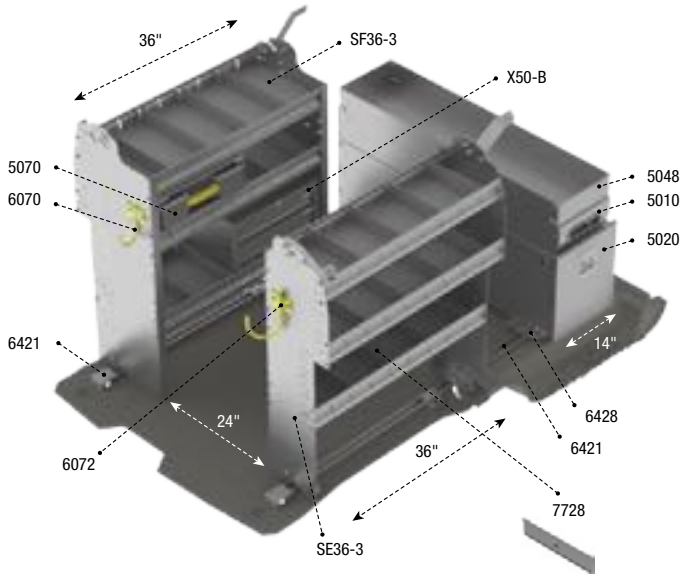

## C511 Electrical Package

**Aluminum**

120.5"

Standard

185 lbs

5 hrs

Yes

Qty	Part #	Description
1	5010	Partslider drawer
1	5020	Tool drawer
1	5048	Partslider drawer, top edge
1	5070	Partskeeper case with shelf mount holder
1	6070	Large hook, fixed
1	6072	Large hook, swivel
2	6421	Shelf unit install kit
1	6428	5020 Tool drawer install kit
1	7728	Locking door kit
1	SE36-3	Shelf unit, contoured
1	SF36-3	Shelf unit, contoured
1	X50-B	Drawer cabinet

**Drill-free installation**



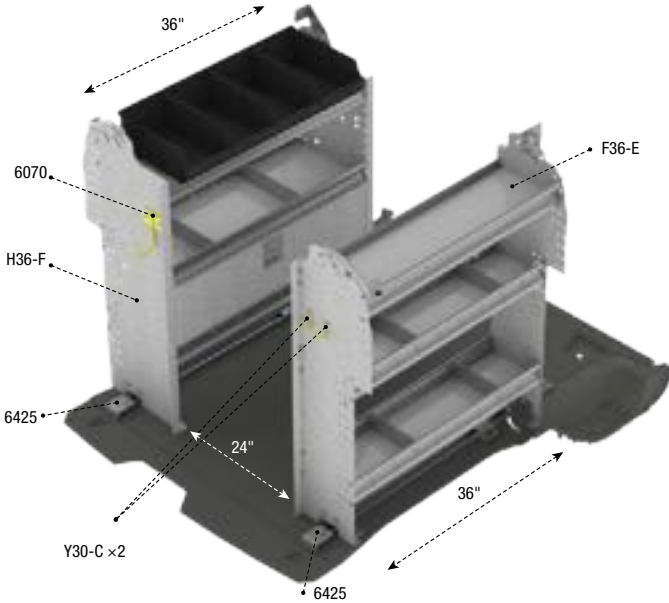

**Z11-C4**  
Electrical Package

**Steel**

105"	Standard	113 lbs
2.6 hrs	Yes	

Qty	Part #	Description
1	6070	Large hook, fixed
2	6425	Shelf unit install kit
1	H36-F	Shelf unit, contoured
1	F36-E	Bin unit, contoured
2	Y30-C	Small hook

**Drill-free installation**

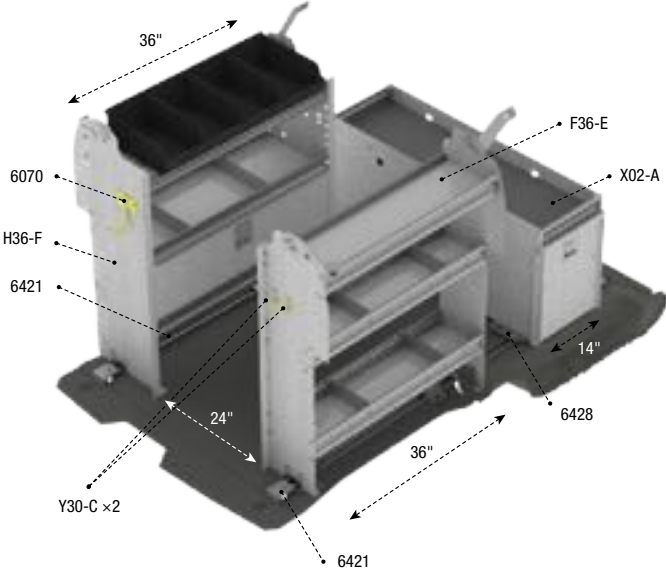

**Z11-C5**  
Electrical Package

**Steel**

120.5"	Standard	196 lbs
3.6 hrs	Yes	

Qty	Part #	Description
1	6070	Large hook, fixed
2	6421	Shelf unit install kit
1	6428	5020 Tool drawer install kit
1	F36-E	Shelf unit, contoured
1	H36-F	Bin unit, contoured
1	X02-A	Tool drawer
2	Y30-C	Small hook

**Drill-free installation**



# Z16-C5

## Service Package

### **TOUGH**

Extrusion builds durability into shelf.

### **QUIET**

The combination of the extrusion, shelf tray, and end-panels create durable, vibration-free shelves.

### **EFFICIENT**

Ergonomic design reduces injuries and increases productivity.



\*Preproduction model shown,  
do not use as an installation guide.

# SERVICE PACKAGES

PACKAGES

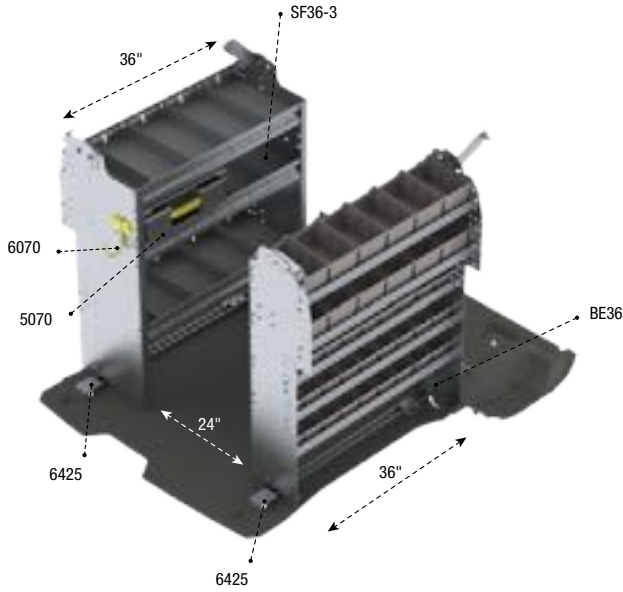

## C416 Service Package

**Aluminum**

105"

Standard

92 lbs

2.5 hrs

Yes

Qty	Part #	Description
1	5070	Partskeeper case with shelf mount holder
1	6070	Large hook, fixed
2	6425	Shelf unit install kit
1	BE36	Bin unit, contoured
1	SF36-3	Shelf unit, contoured

**Drill-free installation**

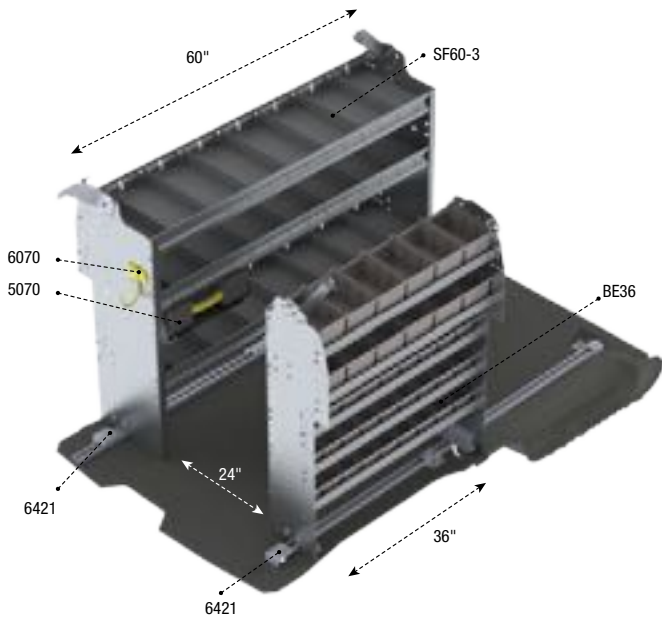

## C516 Service Package

**Aluminum**

120.5"

Standard

108 lbs

2.5 hrs

Yes

Qty	Part #	Description
1	5070	Partskeeper shelf mount
1	6070	Large hook, fixed
2	6421	Shelf unit install kit
1	BE36	Bin unit, contoured
1	SF60-3	Shelf unit, contoured

**Drill-free installation**

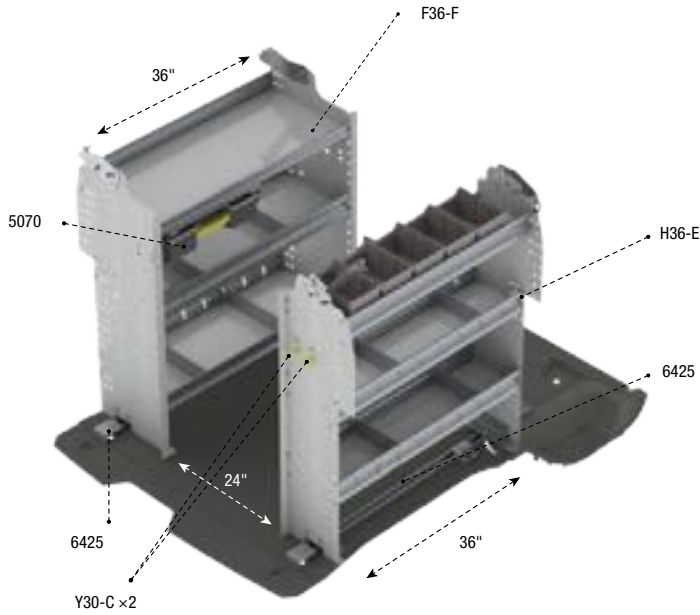

## Z16-C4 Service Package

**Steel**

105"	Standard	122 lbs
2.7 hrs	Yes	

Qty	Part #	Description
1	5070	Partskeeper case with shelf mount holder
2	6425	Shelf unit install kit
1	F36-E	Shelf unit, contoured
1	H36-E	Bin unit, contoured
2	Y30-C	Small hook

**Drill-free installation**

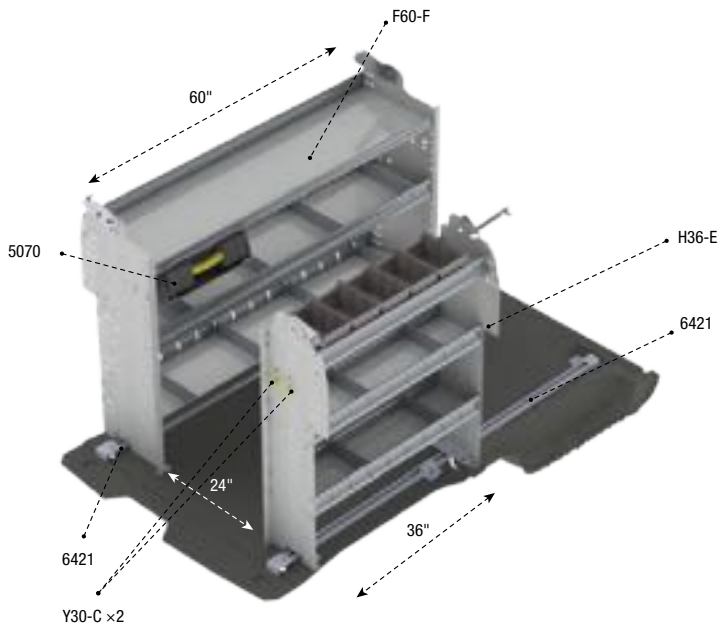

## Z16-C5 Service Package

**Steel**

120.5"	Standard	141 lbs
2.7 hrs	Yes	

Qty	Part #	Description
1	5070	Partskeeper case with shelf mount holder
2	6421	Shelf unit install kit
1	F60-F	Shelf unit, contoured
1	H36-E	Bin unit, contoured
2	Y30-C	Small hook

**Drill-free installation**



# C419

## Delivery Package

### **TOUGH**

Extrusion builds durability into shelf.

### **QUIET**

The combination of the extrusion, shelf tray, and end-panels create durable, vibration-free shelves.

### **EFFICIENT**

Ergonomic design reduces injuries and increases productivity.



\*Preproduction model shown,  
do not use as an installation guide.

# DELIVERY PACKAGES

PACKAGES

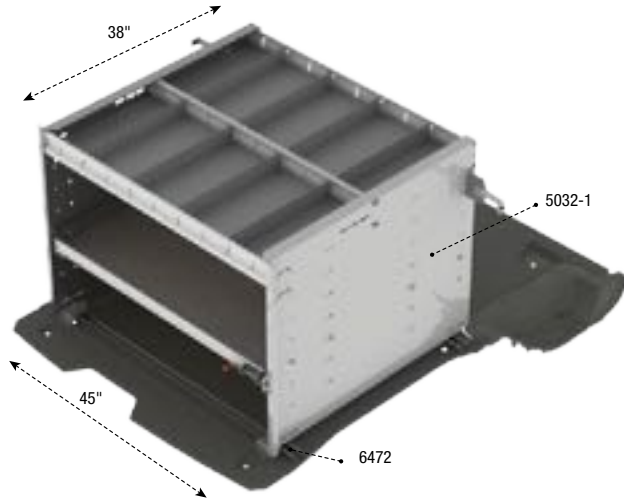

## C419 Delivery Package

**Aluminum**

105", 120.5"	Standard	89 lbs
1 hr	Yes	

Qty	Part #	Description
1	5032-1	Drawer, Access Tray
1	6472	Access tray install kit

**Drill-free installation**

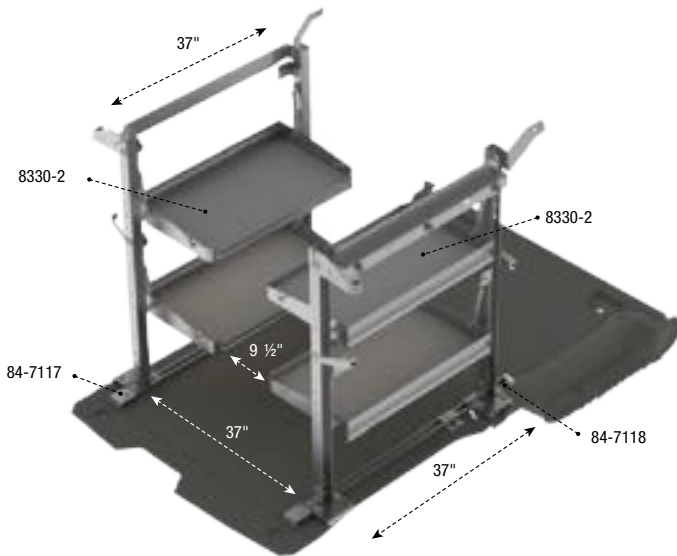

## C519 Delivery Package

**Aluminum**

120.5"	Standard	90 lbs
2.6 hrs	Yes	

Qty	Part #	Description
2	8330-2	Shelf unit, Fold-Away
1	84-7117	Fold-Away install kit
1	84-7118	Fold-Away install kit

**Drill-free installation**



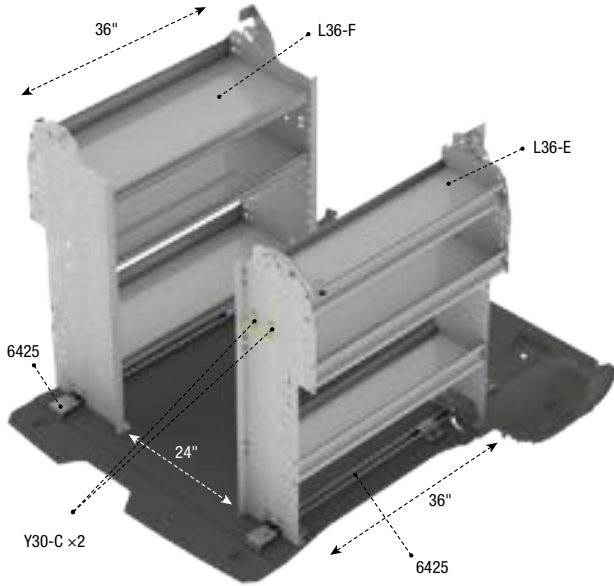

## Z19-C4

Delivery Package

**Steel**

105"	Standard	122 lbs
2.4 hrs	Yes	

Qty	Part #	Description
2	6425	Shelf unit install kit
1	L36-E	Shelf unit, contoured
1	L36-F	Shelf unit, contoured
2	Y30-C	Small hook

**Drill-free installation**

PACKAGES

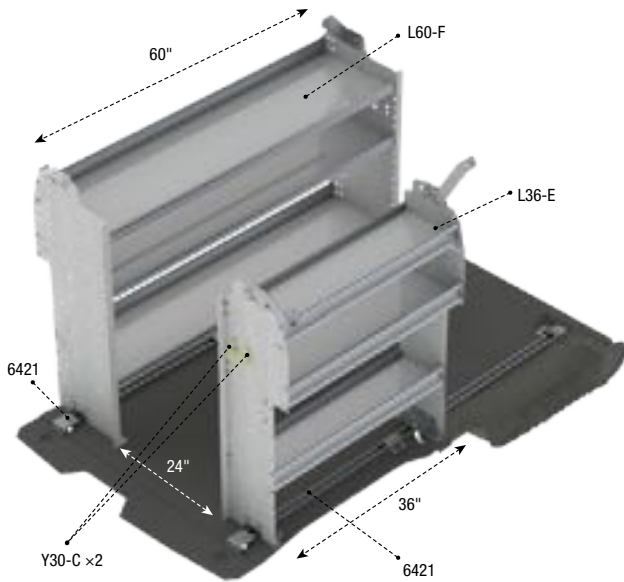

## Z19-C5

Delivery Package

**Steel**

120.5"	Standard	143 lbs
2.4 hrs	Yes	

Qty	Part #	Description
2	6421	Shelf unit install kit
1	L36-E	Shelf unit, contoured
1	L60-F	Shelf unit, contoured
2	Y30-C	Small hook

**Drill-free installation**

# SHELVING

Industry leading strength.  
The perfect fit for the toughest jobs.

## CONTOURED UNITS

- CONTOURED BIN SHELVING UNIT . . . . . P. 35
- CONTOURED SHELVING UNIT . . . . . P. 35
- CONTOURED SHELVING UNIT W/ DIVIDERS . . . . . P. 36
- SHELVING DOORS . . . . . P. 38

## FOLD-AWAY SHELVING . . . . . P. 37

## WORKBENCHES . . . . . P. 37

Ranger Design shelving is built strong and durable and often outlasts the vehicle. Designed to fit with maximum efficiency, Ranger shelving optimizes the space in a work van's cargo area.



**TOUGH**  
Extrusion builds durability into shelf



**QUIET**  
Shelf tray, end panel and extrusion are engineered to be vibration free



**ORGANIZED**  
A well-Planned van outfit increases productivity

# CONTOURED BIN SHELVING UNIT – SHELVING

Contoured Bin Shelving Unit

Aluminum							
							
<b>BE36</b>	12.5" D x 36" W x 40" H	49 lbs			27 (sm), 12 (md)	1 hr	Yes



Contoured Bin Shelving Unit

Steel							
							
<b>H36-E</b>	12.5" D x 36" W x 44" H	60 lbs				1 hr	Yes



Contoured Bin Shelving Unit

Steel							
							
<b>H36-F</b>	17.5" D x 36" W x 44" H	63 lbs				1 hr	Yes



Contoured Shelving Unit

Steel							
							
<b>L36-E</b>	15" D x 36" W x 44" H	60 lbs				1 hr	Yes





SHELVING



# SHELVING – CONTOURED SHELVING UNIT

## Contoured Shelving Unit







### Steel

							
<b>L36-F</b>	15" D x 36" W x 44" H	62 lbs				1 hr	Yes
<b>L60-F</b>	15" D x 60" W x 44" H	83 lbs				1 hr	Yes



## Contoured Shelving Unit with Dividers







### Aluminum

							
<b>SE36-3</b>	12.5" D x 36" W x 44" H	36 lbs	3 Shelves (8", 11", 10")	12	7728	1 hr	Yes



## Contoured Shelving Unit with Dividers







### Aluminum

							
<b>SF36-3</b>	17.5" D x 36" W x 44" H	36 lbs	3 Shelves (15", 16", 13")	12	7733	1 hr	Yes
<b>SF60-3</b>	17.5" D x 60" W x 44" H	52 lbs	3 Shelves (15", 16", 13")	21	7732	1 hr	Yes



## Contoured Shelving Unit with Dividers

### Steel







							
<b>F36-E</b>	12.5" D x 36" W x 44" H	52 lbs	3 Shelves (8", 8", 10")	4	Y11-E	1 hr	Yes



# CONTOURED SHELVING UNIT WITH DIVIDERS – SHELVING

## Contoured Shelving Unit with Dividers







**Steel**

							
<b>F36-F</b>	17.5" D x 36" W x 44" H	55 lbs	3 Shelves (13", 13", 15")	4	Y11-E	1 hr	Yes
<b>F60-F</b>	17.5" D x 60" W x 44" H	74 lbs	3 Shelves (13", 13", 15")	8	Y12-E	1 hr	Yes



## Fold-Away Shelving

**Aluminum**

							
<b>8330-2</b>	18" D x 37" W x 46.5" H	45 lbs	2 Shelves (17", 17")			1.3 hrs	Yes
<b>8348-2</b>	18" D x 55" W x 46.5" H	52 lbs	2 Shelves (17", 17")			1.31 hrs	No

\*Weight capacity for fold-away shelving is 65 lbs / linear foot.



## Square Back Bin Shelving Unit

**Aluminum**

							
<b>7848</b>	11" D x 48" W x 13.25" H	25 lbs			16 (md)	0.5 hr	No



## 7247

Workbench w/hardwood top, one end panel (Drawer cabinet not included)

**Aluminum**



				
	18" D x 48" W x 28" H	47 lbs	1 hr	No

## 7248

Workbench w/hardwood top, two bin shelves

**Aluminum**



				
	18" D x 48" W x 28" H	75 lbs	1 hr	Yes

# SHELVING – DOORS



Shelving Doors

Aluminum					
		Use with shelf width			
7720	44.88" W x 8.69" H	48", 96"	7 lbs	0.5 hr	No
7722	56.88" W x 8.69" H	60"	9 lbs	0.5 hr	No
7723	32.88" W x 8.69" H	36", 72"	5 lbs	0.5 hr	No
7724	20.88" W x 8.69" H	24"	4 lbs	0.5 hr	No
7725	44.88" W x 10.38" H	48", 96"	8 lbs	0.5 hr	Yes
7727	56.88" W x 10.38" H	60"	9 lbs	0.5 hr	No
7728	32.88" W x 10.38" H	36", 72"	6 lbs	0.5 hr	Yes
7729	20.88" W x 10.38" H	24"	4 lbs	0.5 hr	No
7730	44.88" W x 12.06" H	48", 96"	8 lbs	0.5 hr	Yes
7731	38.88" W x 12.06" H	84"	8 lbs	0.5 hr	No
7732	56.88" W x 12.06" H	60"	10 lbs	0.5 hr	No
7733	32.88" W x 12.06" H	36", 72"	6 lbs	0.5 hr	No
7734	20.88" W x 12.06" H	24"	5 lbs	0.5 hr	No
7735	44.88" W x 13.75" H	48", 96"	9 lbs	0.5 hr	No
7737	56.88" W x 13.75" H	60"	11 lbs	0.5 hr	No
7738	32.88" W x 13.75" H	36", 72"	7 lbs	0.5 hr	No
7739	20.88" W x 13.75" H	24"	5 lbs	0.5 hr	No



Shelving Doors

Steel					
		Use with shelf width			
Y10-B	19.88" W x 8.69" H	56"	7 lbs	0.5 hr	No
Y10-C	34.88" W x 8.69" H	70"	9 lbs	0.5 hr	Yes
Y10-D	37.88" W x 8.69" H	38"	10 lbs	0.5 hr	No
Y10-F	41.88" W x 8.69" H	42", 87"	12 lbs	0.5 hr	Yes
Y10-H	47.88" W x 8.69" H	48"	14 lbs	0.5 hr	No
Y10-M	31.88" W x 8.69" H	32"	8 lbs	0.5 hr	No
Y11-C	34.88" W x 10.38" H	70"	10 lbs	0.5 hr	Yes
Y11-D	37.88" W x 10.38" H	38"	11 lbs	0.5 hr	Yes
Y11-E	35.88" W x 10.38" H	36"	10.5 lbs	0.5 hr	No
Y11-F	41.88" W x 10.38" H	42", 87"	13 lbs	0.5 hr	Yes
Y11-M	31.88" W x 10.38" H	32"	8 lbs	0.5 hr	No
Y12-C	34.88" W x 12.06" H	70"	10 lbs	0.5 hr	No
Y12-D	37.88" W x 12.06" H	38"	12 lbs	0.5 hr	No
Y12-F	41.88" W x 12.06" H	42", 87"	14 lbs	0.5 hr	No
Y12-M	31.88" W x 12.06" H	32"	8 lbs	0.5 hr	No



Shelf Block

Aluminum					
		Use with shelf width			
7740	12" W x 16.5" H	All	3 lbs	0.5 hr	No



Shelving Doors

Steel					
		Use with shelf width			
Y10-J	55.88" W x 8.69" H	56"	15 lbs	0.5 hr	No
Y11-J	55.88" W x 10.38" H	56"	16 lbs	0.5 hr	No
Y12-J	55.88" W x 12.06" H	56"	17 lbs	0.5 hr	No



**TOUGH**

Proline drawers are backed by a 10 year warranty.



**QUICK**

Easy to use slam latch.



**SECURE**

Keyed lock to guard valuables.

# DRAWERS

Durable storage compartments, designed for quick and easy access.

- AXESS TRAYS . . . . . P. 40
- COMPACT DRAWERS . . . . . P. 44
- DRAWER CABINETS . . . . . P. 43
- PARTSKEEPERS . . . . . P. 45
- PARTSLIDERS . . . . . P. 43
- TOOL DRAWERS . . . . . P. 46

Ranger Design manufactures a variety of tough, quiet drawer systems and storage modules. Using top quality components such as full-extension, high-capacity ball-bearing drawer slides, secure locks, and Ranger Design’s unique braided stainless steel cable-pull handles. These drawers are the organizational quality that you deserve.

If you never again want to experience the frustration of drawers that jam, sag, and don’t latch properly, we have the solution.



# DRAWERS



## 5032-0

Axess Tray with 1 shelf / no drawers

### Aluminum

38" D x 45" W x 30" H

—

51 lbs

0.9 hr

No



## 5032-1

Axess Tray with 1 shelf / 1 drawer

### Aluminum

38" D x 45" W x 30" H

200 lbs

89 lbs

1 hr

Yes



## 5032-2

Axess Tray with 1 shelf / 2 drawers

### Aluminum

38" D x 45" W x 30" H

200 lbs

127 lbs

1.1 hrs

No



## 5032-3

Axess Tray with 1 shelf / 3 drawers

### Aluminum

38" D x 45" W x 30" H

200 lbs

165 lbs

1.2 hrs

No



## 5032-A

Axess Tray drawer only,  
complete with slides

### Aluminum

38" D x 45" W

—

38 lbs

—

No

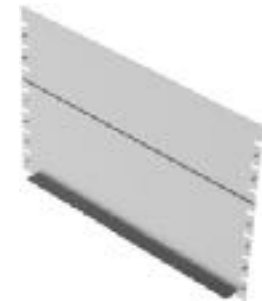

## 5032-F

Axess Tray full back panel for 5032 series

### Aluminum

41" W x 27.25" H

—

8 lbs

0.25 hr

No





# DRAWERS



## 5037-0

Axess Tray with 1 shelf / no drawers

### Aluminum

38" D x 45" W x 42" H

—

55 lbs

1 hr

No



## 5037-1

Axess Tray with 1 shelf / 1 drawer

### Aluminum

38" D x 45" W x 42" H

200 lbs

93 lbs

1.1 hrs

No



## 5037-2

Axess Tray with 1 shelf / 2 drawers

### Aluminum

38" D x 45" W x 42" H

200 lbs

131 lbs

1.2 hrs

No



## 5037-3

Axess Tray with 1 shelf / 3 drawers

### Aluminum

38" D x 45" W x 42" H

200 lbs

169 lbs

1.3 hrs

No



## 5037-A

Axess Tray drawer only, c/w slides

### Aluminum

38" D x 45" W

—

38 lbs

—

No



## 5037-F

Axess Tray full back panel for 5037 series

### Aluminum

41" W x 39.25" H

—

11 lbs

0.25 hr

No



## 5010

Partslider drawer

### Aluminum

48" D x 12" W x 6" H

150 lbs

30 lbs

0.5 hr

Yes



## 5011

Partslider drawer

### Aluminum

36" D x 12" W x 6" H

150 lbs

26 lbs

0.5 hr

No

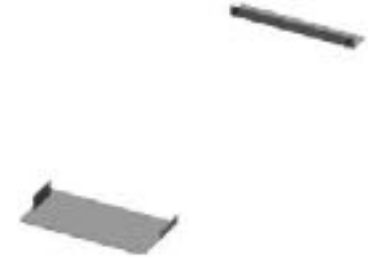

## 5014

Floor mount kit for 5010 / 5011 Partslider drawer

### Aluminum

-

-

1 lb

-

No



## 5048

Top edge, for 5010 Partslider

### Aluminum

48" D x 12" W x 4" H

-

5 lbs

0.2 hr

Yes



## 5051

Top edge, for 5011 Partslider

### Aluminum

36" D x 12" W x 4" H

-

4 lbs

0.2 hr

No



## 5060-5

5 Drawer cabinet and 1 door

### Aluminum

18" D x 24" W x 36" H

150 lbs

104 lbs

1 hr

No

# DRAWERS

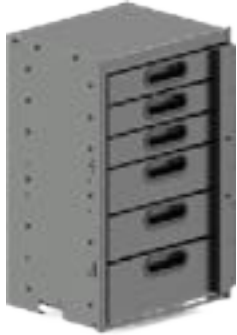

## 5060-6

6 Drawer cabinet

### Aluminum

18" D x 24" W x 36" H

150 lbs

114 lbs

1 hr

No



## 5060-8

8 Drawer cabinet

### Aluminum

18" D x 24" W x 36" H

150 lbs

148 lbs

1 hr

No



## 5067-6

6 Drawer cabinet

### Aluminum

18" D x 18" W x 28" H

150 lbs

97 lbs

0.5 hr

No



## 5068-3

3 Drawer cabinet

### Aluminum

18" D x 15" W x 15" H

150 lbs

45 lbs

0.5 hr

Yes



## 5069-2

2 Drawer cabinet

### Aluminum

14" D x 24" W x 12" H

150 lbs

34 lbs

0.5 hr

Yes



## X50-B

Compact 2-Drawer Unit

### Steel

12.5" D x 18.5" W x 10.5" H

—

19 lbs

0.3 hr

Yes



## X50-C

Compact 3-Drawer Unit

### Steel

12.5" D x 18.5" W x 10.5" H

-

20 lbs

0.3 hr

Yes



## X51-F

Compact 9-Drawer Unit

### Steel

12" D x 17" W x 12" H

-

26 lbs

0.3 hr

Yes



## 5070

Partskeeper carry case with holder, universal

### Aluminum

14" D x 17" W x 5.5" H

-

7 lbs

0.3 hr

Yes



## 5072

Partskeeper carry case with holder, floor mount

### Aluminum

14" D x 17" W x 8.75" H

-

7 lbs

0.3 hr

No



## 5078

Partskeeper cabinet with 4 carry cases

### Aluminum

14" D x 17" W x 24" H

-

23 lbs

0.3 hr

Yes

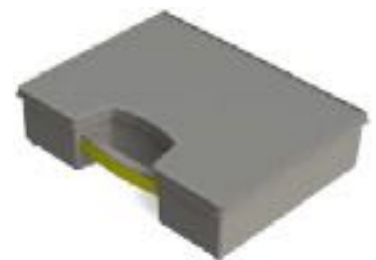

## 5079

Partskeeper carry case

### Plastic

13" D x 16.5" W x 4" H

-

3 lbs

-

No

# DRAWERS



## 5082

Partskeeper cabinet with 8 carry cases

### Aluminum

14" D x 17" W x 43" H

—

48 lbs

1 hr

Yes



## 5083

Partskeeper cabinet with 5 carry cases & 2 shelves

### Aluminum

14" D x 17" W x 43" H

—

41 lbs

1 hr

Yes



## 5020

Tool drawer

### Aluminum

48" D x 14" W x 16" H

320 lbs

46 lbs

1 hr

Yes



## 5021

Tool drawer

### Aluminum

36" D x 14" W x 16" H

320 lbs

39 lbs

1 hr

No



## 5025

Jumbo tool drawer

### Aluminum

48" D x 16" W x 19" H

320 lbs

61 lbs

1 hr

Yes



## 5026

Jumbo tool drawer

### Aluminum

36" D x 16" W x 19" H

320 lbs

54 lbs

1 hr

No



## 5028

Raised base for 5020 tool drawer

### Aluminum

6" D x 14" W x 6" H

—

8 lbs

0.5 hr

No



## 5029

Raised base for 5025 Jumbo tool drawer

### Aluminum

6" D x 16" W x 6" H

—

8 lbs

0.5 hr

No



## X02-A

Fleetline Tool Drawer

### Steel

45.5" D x 13.5" W x 27.5" H

—

80 lbs

1 hr

Yes



Two **5078** Partskeeper cabinet mounted side by side.

### LEGEND



Dimensions



Weight Capacity



Weight



Install Time



Quickship

# ACCESSORIES

Choose the finishing details to tailor the upfit to your specific needs.

BINS .....	P. 49
BOTTLE HOLDERS .....	P. 50
HOOKS .....	P. 52
OTHERS .....	P. 53
PAPER HOLDERS .....	P. 55
WINDOW GRILLS .....	P. 56

The finishing details are just as important when you're setting up your commercial van as they are when you're on the job site. Customize your vehicle with our wide range of options to ensure that you can perform at peak efficiency.



### VERSATILE

Removable storage bins ensure organization on the jobsite or on the go.



### SECURE

Trade specific accessories with a place for all tools and supplies.







### PRODUCTIVE

Stay productive with the most used items well within reach.









**6205**  
Bin cup

Plastic	
	4.5" D x 3.25" W x 3.75" H
	0.12 lb
	–
	No







**6211**  
Small Bin, Graphite

Plastic	
	6.5" D x 4" W x 3" H
	0.24 lb
	–
	Yes







**6212**  
Divider for 6211 small bin

Aluminum	
	–
	–
	–
	No







**6221**  
Medium Bin, Graphite

Plastic	
	10" D x 6" W x 4.5" H
	0.56 lb
	–
	Yes







**6222**  
Divider for 6221 medium bin

Aluminum	
	–
	–
	–
	No



**6231**  
Large Bin, Graphite

Plastic	
	14" D x 8" W x 5.5" H
	1.33 lbs
	–
	Yes

# ACCESSORIES

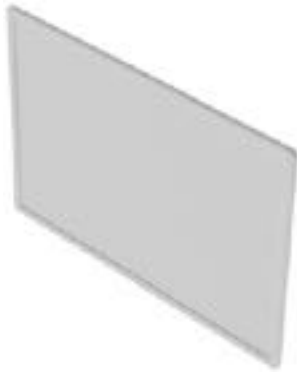

## 6232

Divider for 6231 large bin

### Aluminum

—

—

—

No



## 6006

3 Tier refrigerant rack for small bottles

### Aluminum

14" D x 10.5" W x 43" H

20 lbs

0.6 hr

No

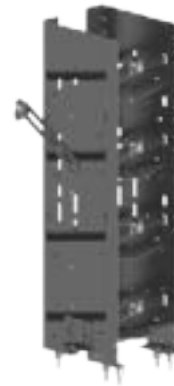

## 6007

4 Tier refrigerant rack for small bottles

### Aluminum

14" D x 10.5" W x 43" H

22 lbs

0.6 hr

Yes



## 6008

3 Tier refrigerant rack for large bottles

### Aluminum

14" D x 13" W x 43" H

22 lbs

0.6 hr

No



## 6010

Two level adjustable bottle holder

### Aluminum

10.25" D x 9.5" W x 36" H

5 lbs

0.4 hr

No



## 6020

Horizontal refrigerant bottle holder

### Aluminum

12.5" D x 48" W x 13" H

17 lbs

0.5 hr

No



## 6030

Bottle rack with straps

### Aluminum

48" W

4 lbs

0.5 hr

No



## 6035

Bottle rack with straps

### Aluminum

60" W

5 lbs

0.5 hr

No



## 6040

Locking cabinet

### Aluminum

8.5" D x 12" W x 24" H

16 lbs

0.6 hr

No



## 6041

Locking cabinet

### Aluminum

15" D x 15.5" W x 33" H

26 lbs

0.7 hr

No



## 6049

Ventilation kit for cabinet

### Aluminum

—

—

—

No



## 6088

Large aluminum bottle holder, comes with two black nylon straps

### Aluminum

8" W x 24" H

2 lbs

0.2 hr

Yes

# ACCESSORIES



## 6086

Small aluminum bottle holder, comes with a black nylon strap

### Aluminum

6" W x 12" H

1 lb

0.2 hr

Yes



## 6070

6" Hook, 3" opening, painted

### Steel

3" D

0.4 lb

0.2 hr

Yes



## 6072

8" Swivel Hook, 4" opening, painted

### Steel

4" D

0.6 lb

0.2 hr

Yes

ACCESSORIES



## 6073

Large aluminum movable hook, 6.5" opening

### Aluminum

6.5" D x 2.75" W x 4" H

1 lb

0.01 hr

Yes



## Y30-C

Coat Hook, 1" opening, chrome plated

### Steel

1" D

0.1 lb

0.2 hr

Yes



6070 6" Hook, 3" opening, painted



## 1130

Elevated strobe mount

### Aluminum

8" W

1 lb

0.1 hr

No



## 6050

Flettner vent, rotary design

### Plastic

8.9" D

1.5 lbs

1 hr

No



## 6052

Vise Holder with an 8"x8" mounting plate

### Steel

—

37 lbs

0.5 hr

No



## 6054

Hitch Step, comes with hitch pin to fit a 2"x2" hitch

### Aluminum

6" D x 12" W

4 lbs

—

No



## 6057

Can Holder

### Aluminum

3" D x 8.5" W x 3" H

1 lb

0.2 hr

No



## 6075

Transport tube door, for 6" diameter tube with stainless steel hardware

### Aluminum

6" D

2 lbs

0.2 hr

No

# ACCESSORIES



## 6078

Cradle & strap kit for 6" diameter transport tube (one cradle and one strap)

### Aluminum

□ 6" D

⬆ 1 lb

🕒 0.1 hr

⚠ No



## 6079

Transport tube door kit complete (Tube not included)

### Aluminum

□ 6" D

⬆ 6 lbs

🕒 0.8 hr

⚠ No



## 6082

Triangle kit with aluminum holder

### Other

□ -

⬆ 14 lbs

🕒 0.2 hr

⚠ No

ACCESSORIES



## 6090

Back up alarm, die cast housing, fully encapsulated circuitry

### Other

□ -

⬆ 1 lb

🕒 1 hr

⚠ No



## 6091

Surface mount tie down ring, zinc plated

### Steel

□ 4" D

⬆ 0.4 lb

🕒 0.2 hr

⚠ No



## 6092

Dome Light, chrome finish housing

### Other

□ 8.5" D

⬆ 1 lb

🕒 1 hr

⚠ No



## 6093

Grab handle

### Plastic

9.5" D

0.1 lb

0.5 hr

No



## 7124

Reel Holder with two 5/8" diameter rods

### Aluminum

7.25" D x 15" W x 24" H

9 lbs

0.5 hr

Yes



## 6061

Paper Holder, extra deep, 2 slots

### Aluminum

3.75" D x 12.75" W x 12" H

2 lbs

0.2 hr

No



## 6063

Paper Holder, extra deep, 5 slots

### Aluminum

3.75" D x 12.75" W x 24" H

5 lbs

0.2 hr

Yes



## 6066

2 Pocket Holder, comes with 8 plastic bins

### Aluminum

4.5" D x 20" W x 21.75" H

7.5 lbs

0.2 hr

No



## 6067

Paper Holder, regular depth, 2 slots

### Aluminum

2.25" D x 12.75" W x 12" H

2 lbs

0.2 hr

No

# ACCESSORIES



## 6068

Hard Hat Holder, painted wire

### Steel

–

0.5 lb

0.2 hr

No



## 6069

Paper Holder, regular depth, 5 slots

### Aluminum

2.25" D x 12.75" W x 24" H

5 lbs

0.2 hr

No



## Y31-A

Paper Holder, extra deep, 3 slots

### Steel

3.75" D x 12.75" W x 16" H

9 lbs

0.2 hr

Yes

ACCESSORIES

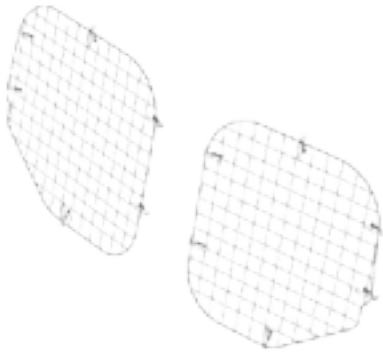

## 6124

Set of 2 rear window grills

### Steel

Standard Roof

8 lbs

0.2 hr

No

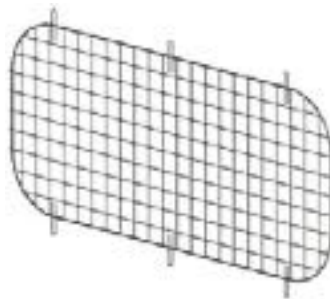

## 3044

Grill for partition window for 3020, 3025, 3068 and 3069

### Aluminum

–

2 lbs

–

No



## 3024

Partition window with frame for 3020, 3025, 3068 and 3069

### Aluminum

–

2 lbs

–

No



INTRODUCING THE NEW RANGER DESIGN

# SEAT COVERS





## OUR KEY ADVANTAGES INCLUDE:

- › Durable material and easy maintenance
- › Urethane coating to make the fabric water and stain resistant
- › Machine wash and dryer safe
- › Easy installation of 30 minutes or less for a set
- › No interference with factory seat functions (heating, cooling or air bag)
- › Minimal seams
- › Tight custom fit for each vehicle, guaranteed to stay in place
- › Puncture resistant to prevent seat damage
- › Durable Cordura® fabric with a 1 year warranty

6256

## SPECIFICATIONS

for 1 set of bucket seat covers

	4 lbs
	0.5 hr
	Yes

**THE PERFECT FIT**  
FOR YOUR TOUGHEST JOBS

**RANGER**<sup>TM</sup>  
DESIGN

*Our Promise: To Help You Work More Effectively by Providing Organized Storage Solutions.*

# LADDER RACKS

Ergonomic Ladder Racks make loading and unloading easier.

Ranger ladder racks make loading and unloading ladders an easy operation. Ranger Design offers drop-down ladder racks for high roof vans, extra tough racks capable of carrying 28' ladders on compact vans, interior ladder carriers and many other options for different applications.



## TOUGH

Military grade aluminum extrusion, high density plastic and stainless steel components ensure no corrosion over the lifetime of the rack.



## QUIET

Aerodynamic design with minimal wind noise.



## SAFE

No metal contact to ladder, leading to longer life of ladders with less chance of fiberglass splinters.



Access Pro, Inside Ladder Carrier

**Aluminum**

<b>1050-M</b>	Universal	—	60"	9 lbs	1 hr	



Standard ladder rack

**Aluminum**

<b>1510-TC</b>	Universal	—	60"	400 lbs	18 lbs	0.9 hr



Ladder rack accessory

**Aluminum**

<b>1127</b>	Universal	Universal		18 lbs	0.5 hr	



Single clamp ladder rack

**Aluminum**

<b>1520-TC</b>	Universal	—	60"	400 lbs	28 lbs	1.2 hrs



Cargo rack

**Aluminum**

<b>1505-TC</b>	Universal	—	60"	480 lbs	18 lbs	0.8 hr



Combination ladder rack

**Aluminum**

<b>1525-TC</b>	Universal	—	60"	400 lbs	47 lbs	1.7 hrs

# LADDER RACKS & INSTALL KITS



Combination ladder rack

## Aluminum

<b>1525-TCX</b>	Universal	—	60"	400 lbs	52 lbs	1.7 hrs



Double clamp ladder rack

## Aluminum

<b>1530-TC</b>	Universal	—	60"	400 lbs	36 lbs	1.7 hrs



Double clamp ladder rack

## Aluminum

<b>1530-TCX</b>	Universal	—	60"	400 lbs	36 lbs	1.7 hrs

# INSTALL KITS



Product #	Transit Connect Short Wheelbase	Transit Connect Long Wheelbase
5025, 5020, X02-A	—	6428
32" Shelving Driver side	—	—
32" Shelving Passenger side	—	—
36" Shelving Driver side	6425	6421
36" Shelving Passenger side	6425	6421
All 56" Shelving	—	—
60" Shelving Driver side	—	6421
60" Shelving Passenger side	—	—
Axess Tray	6472	6472
Fold Away Shelving Driver side	—	84-7117
Fold Away Shelving Passenger side	—	84-7118

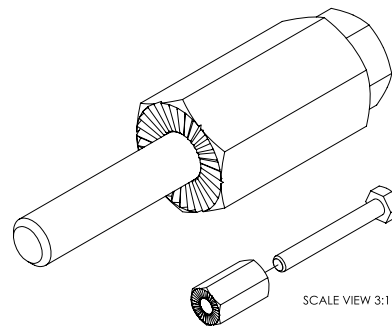

The Plus Nut/Riv-Nut tool (#6490) is available at no charge upon request.

1050-M	59	5078	45	6421	60	F36-F	37
1127	59	5079	45	6425	60	F60-F	37
1130	53	5082	46	6428	60	H36-E	35
1505-TC	59	5083	46	6472	60	H36-F	35
1510-TC	59	6006	50	6490	60	L36-E	35
1520-TC	59	6007	50	6540-FCS	11	L36-F	36
1525-TC	59	6008	50	6540-FCL	11	L60-F	36
1525-TCX	60	6010	50	7124	55	SE36-3	36
1530-TC	60	6020	50	7247	37	SF36-3	36
1530-TCX	60	6030	51	7248	37	SF60-3	36
3010-TC	13	6035	51	7720	38	X02-A	47
3020-TC	13	6040	51	7722	38	X50-B	44
3024	56	6041	51	7723	38	X50-C	45
3044	56	6049	51	7724	38	X51-F	45
3320-TC	13	6050	53	7725	38	Y10-B	38
5010	43	6052	53	7727	38	Y10-C	38
5011	43	6054	53	7728	38	Y10-D	38
5014	43	6057	53	7729	38	Y10-F	38
5020	46	6061	55	7730	38	Y10-H	38
5021	46	6063	55	7731	38	Y10-J	38
5025	46	6066	55	7732	38	Y10-M	38
5026	46	6067	55	7733	38	Y11-C	38
5028	47	6068	56	7734	38	Y11-D	38
5029	47	6069	56	7735	38	Y11-E	38
5032-0	40	6070	52	7737	38	Y11-F	38
5032-1	40	6072	52	7738	38	Y11-J	38
5032-2	40	6073	52	7739	38	Y11-M	38
5032-3	40	6075	53	7740	38	Y12-C	38
5032-A	40	6078	54	7848	37	Y12-D	38
5032-F	40	6079	54	8330-2	37	Y12-F	38
5037-0	42	6082	54	8348-2	37	Y12-J	38
5037-1	42	6086	52	84-7117	60	Y12-M	38
5037-2	42	6088	51	84-7118	60	Y30-C	52
5037-3	42	6090	54	BE36	35	Y31-A	56
5037-A	42	6091	54	C10-E	13	Z10-C4	21
5037-F	42	6092	54	C12-E	14	Z10-C5	21
5048	43	6093	55	C13-E	14	Z11-C4	25
5051	43	6124	56	C410	20	Z11-C5	25
5060-5	43	6205	49	C411	24	Z16-C4	29
5060-6	44	6211	49	C416	28	Z16-C5	29
5060-8	44	6212	49	C419	32	Z19-C4	33
5067-6	44	6221	49	C510	20	Z19-C5	33
5068-3	44	6222	49	C511	24		
5069-2	44	6231	49	C516	28		
5070	45	6232	50	C519	32		
5072	45	6256	57	F36-E	36		

# Over 350 Distributors Across the Continent

## Regular Order

## Quickship Order

**Buy**

Contact one of our 350 distributors  
[rangerdesign.com/find-dealer](http://rangerdesign.com/find-dealer).

Ranger Quickship service is available  
through your local distributor.

**Lead  
Time**

Orders ship from our factory within  
5 business days.

Orders placed with Ranger before 1PM EST will  
ship from our factory in the next business day.



Throughout the catalog products and packages with this symbol  
can be ordered through our Quickship service.

# Turn-Key Fleet Services



## Ship Through or Local Installation Across North America for all Types of Cargo Vans

We are pleased to offer efficient, personalized service and to answer all questions regarding:

### 1. Analysis

- › Cargo Needs Analysis
- › Custom 3D CAD Layouts
- › Hands-on Equipment Demo

### 2. Testing

- › Test Fitting
- › Pilot Build and Review
- › Optimize Package Based on Technician Feedback

### 3. Delivery

- › Delivery, Production and Installation Planning and Scheduling
- › Vehicle Status Tracking

### 4. Service

- › Dedicated Fleet Account Management Team
- › 300 Ranger Distributor Service Support Network
- › Live Customer Service

# Maximize Cargo Capacity & Vehicle Performance With Contractor Grade, Organized Storage Systems

When you want the perfect upfit solution for your work vehicle, turn to Ranger Design. Tested for toughness, Ranger's shelving and upfits will take whatever abuse you can dish out. Their unsurpassed craftsmanship, combined with ideal fit and finish, provide a quiet ride with no rattles.



## CUSTOMER SERVICE

cs@rangerdesign.com  
1-800-565-5321  
rangerdesign.com



## THE PERFECT FIT FOR YOUR TOUGHEST JOBS