

MERCEDES-BENZ  
**SPRINTER**



**UPFIT**  
GUIDE

**RANGER**<sup>TM</sup>  
DESIGN

# Helping Mobile Technicians Work More Effectively by Providing Organized Storage Solutions

## At Ranger Design, we believe more is possible.

We believe work vehicles and the technicians that drive them can become more organized, more efficient, more productive and more profitable. At Ranger Design we're committed to bringing you the products and services that make that possible.

More means helping you choose the right work van for your

application, as well as giving you engineering support and expert advice to help design the most efficient work space in your new vehicle.

More also means getting that new van outfitted and on the road faster, so you can start using it for the reason you bought it.

We're committed to bringing you more, because we believe more is possible.



**MORE IS POSSIBLE**



## TABLE OF CONTENTS

CHOOSE YOUR PRODUCT LINE .....	P. 4
PLAN YOUR VAN OUTFIT .....	P. 6
GETTING STARTED .....	P. 8
FLOORS .....	P. 10
PARTITIONS .....	P. 12
PACKAGES .....	P. 18
SHELVING .....	P. 36
DRAWERS .....	P. 50
ACCESSORIES .....	P. 60
LADDER RACKS .....	P. 66
HOW TO BUY .....	P. 72
INDEX .....	P. 74

# Choose A Product Line To Match Your Needs

Ranger Fleetline and Proline product groups ensure that fleets of any size have the best equipment to fit their budget, trade or fuel saving targets.



Ranger Design Fleetline shown



Ranger Design Proline shown

	<b>MATERIAL</b>	<b>BENEFITS</b>	<b>PRODUCTS</b>	<b>WARRANTY</b>
<p><b>WHY BUY RANGER FLEETLINE?</b> You want better quality and price than other steel products on the market.</p>	Steel	Tough Low cost Quiet	Shelving, Partitions, Drawers, Accessories	3 years*
<p><b>WHY BUY RANGER PROLINE?</b> You want the toughest, quietest product on the market. You need to optimize payload without sacrificing quality.</p>	Aluminum	<b>Toughest</b> <b>Lightweight</b> Quiet	<b>Shelving, Partitions,</b> <b>Drawers, Accessories,</b> <b>Ladder Racks</b>	<b>10 years*</b>

\*Ranger Design Inc. van equipment is warranted to be free from defects in material and workmanship under normal use and service for the period indicated, from the date of the original retail purchase, when installed per Ranger Design instructions in the original vehicle. Please contact Customer Service for full warranty details. Email: [cs@rangerdesign.com](mailto:cs@rangerdesign.com)

Throughout the catalog **FLEETLINE** products are depicted with yellow and **PROLINE** products with black.

**1-800-565-5321**  
7 A.M. – 8 P.M. EST

# World Class Customer Service



## Real people, ready to answer in 2 rings or less\*

We are pleased to offer efficient, personalized service and to answer all questions regarding:

- › Pricing/Quoting
- › Product install
- › Order status
- › Consultation
- › Shipment status
- › New product availability
- › Product specifications
- › Warranty claims
- › Returns/Restocking
- › Vehicle specifications

\*Call customer service and the phone will be answered in 2 rings or less. Yes, a real, live person working in one of our offices in North America is available to answer your questions. No automated attendant. No complicated phone tree and offshore service. Call us to experience the difference.

# PLAN YOUR VAN OUTFIT

## INSIDE ROOF HEIGHT

To determine the maximum shelf height that can be used in the van.

## PARTITION DEPTH

This indicates the space taken up by our partition for this vehicle. Please note that this measurement is determined by the partition that encroaches the most. Some partitions may take up less space. Take note that this measurement may not necessarily be on the floor.

## DOOR OPENING

To determine where shelving will land in relation to the door opening. Use this measurement to determine the space available for drawer units.

## DIMENSIONS IN RED

These dimensions indicate unique measurements for each wheelbase. Use red dimensions to determine the exact wheelbase of your van.

## FLOOR SPACE

This area is usable floor space but due to curvature of the van there may not be the same available area at the roof. Please measure actual van for specific measurement at roof.

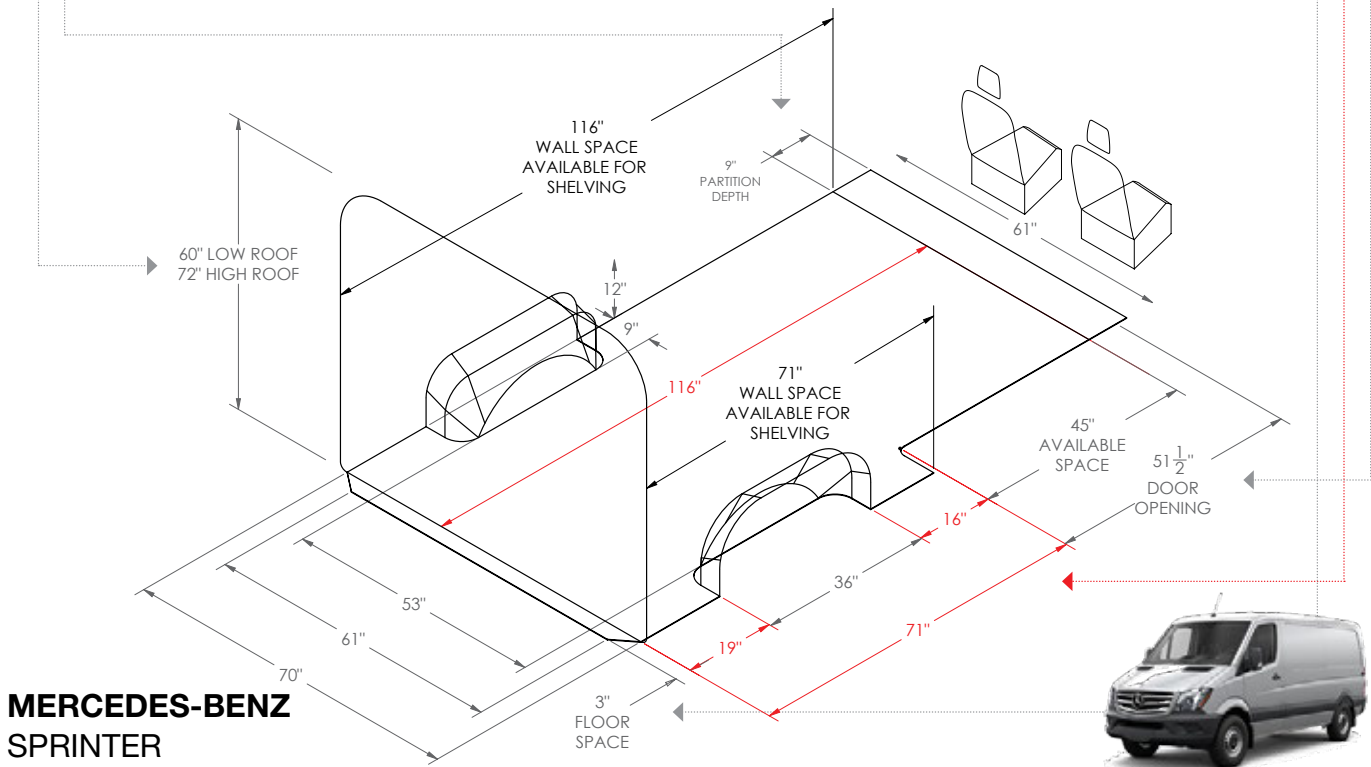

### MERCEDES-BENZ SPRINTER

Regular 144" Wheelbase



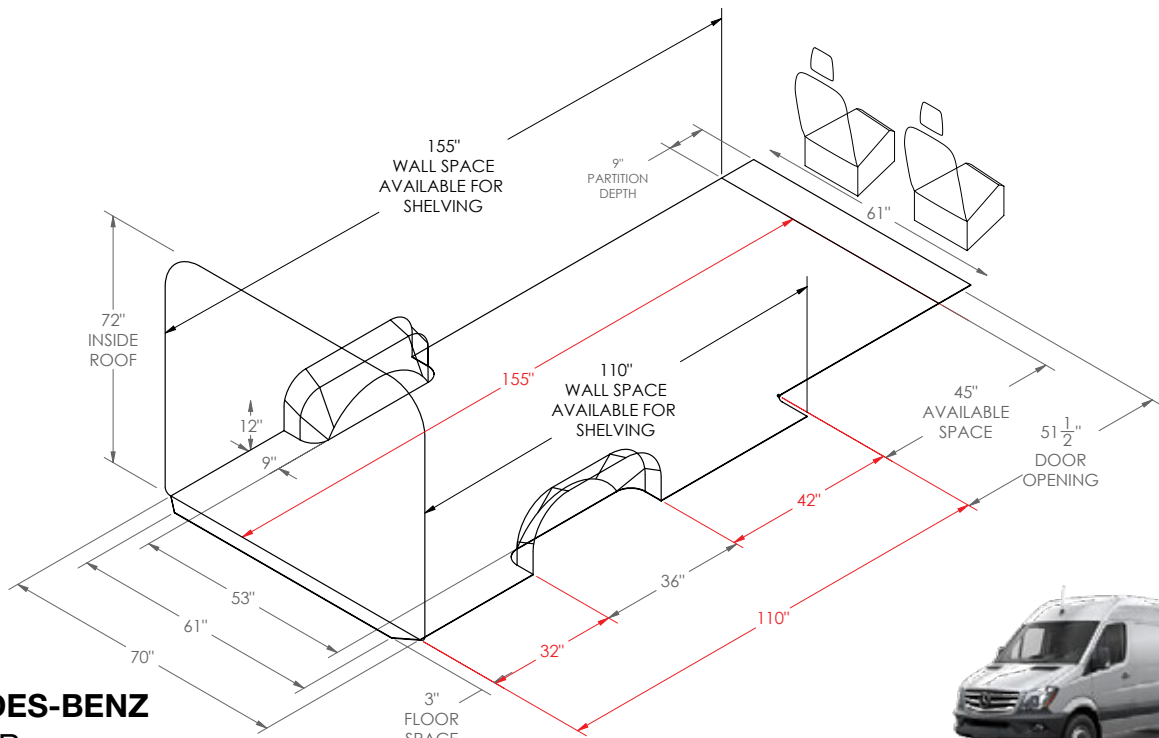

## MERCEDES-BENZ SPRINTER

Long 170" Wheelbase

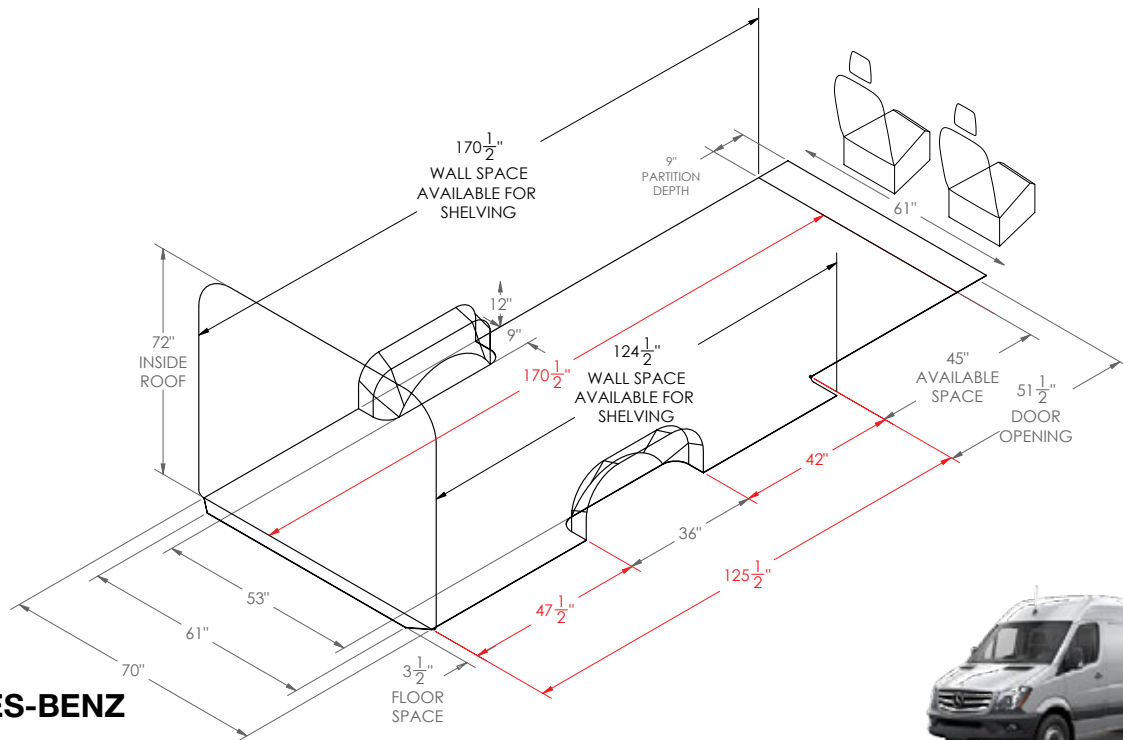

## MERCEDES-BENZ SPRINTER

Extended 170" Wheelbase

# Take a few minutes to write down these simple steps

## Plan your storage zones

For how long do you plan to use the vehicle?  A year  2–5 years  10 years or more (see page 4)

Will payload capacity be an issue?  Yes  No Why? \_\_\_\_\_

What type of industry are you in? \_\_\_\_\_

### What kind of partition do I need?

Do I need to see my cargo or see out the side doors?  Yes  No

Do I need the ability to go from the cabin to the cargo area through the partition?  Yes  No

### List the equipment/products you will need to store

Place the items that you need most often in the most accessible locations.

	How often will you use this?			Zone
	Daily	Weekly	Monthly	
_____	<input type="checkbox"/>	<input type="checkbox"/>	<input type="checkbox"/>	A-B-C-D-E
_____	<input type="checkbox"/>	<input type="checkbox"/>	<input type="checkbox"/>	_____
_____	<input type="checkbox"/>	<input type="checkbox"/>	<input type="checkbox"/>	_____
_____	<input type="checkbox"/>	<input type="checkbox"/>	<input type="checkbox"/>	_____
_____	<input type="checkbox"/>	<input type="checkbox"/>	<input type="checkbox"/>	_____

Will I need to carry larger objects  Yes  No

### List the tools you will need to carry

Place heavy tools closest to the access doors.

	How often will you use this?			Zone
	Daily	Weekly	Monthly	
_____	<input type="checkbox"/>	<input type="checkbox"/>	<input type="checkbox"/>	A-B-C-D-E
_____	<input type="checkbox"/>	<input type="checkbox"/>	<input type="checkbox"/>	_____
_____	<input type="checkbox"/>	<input type="checkbox"/>	<input type="checkbox"/>	_____
_____	<input type="checkbox"/>	<input type="checkbox"/>	<input type="checkbox"/>	_____
_____	<input type="checkbox"/>	<input type="checkbox"/>	<input type="checkbox"/>	_____

What kind of ladder(s) will I be carrying? Step ladder Extension ladders  
 Size \_\_\_\_\_ Size \_\_\_\_\_



# Storage Zones

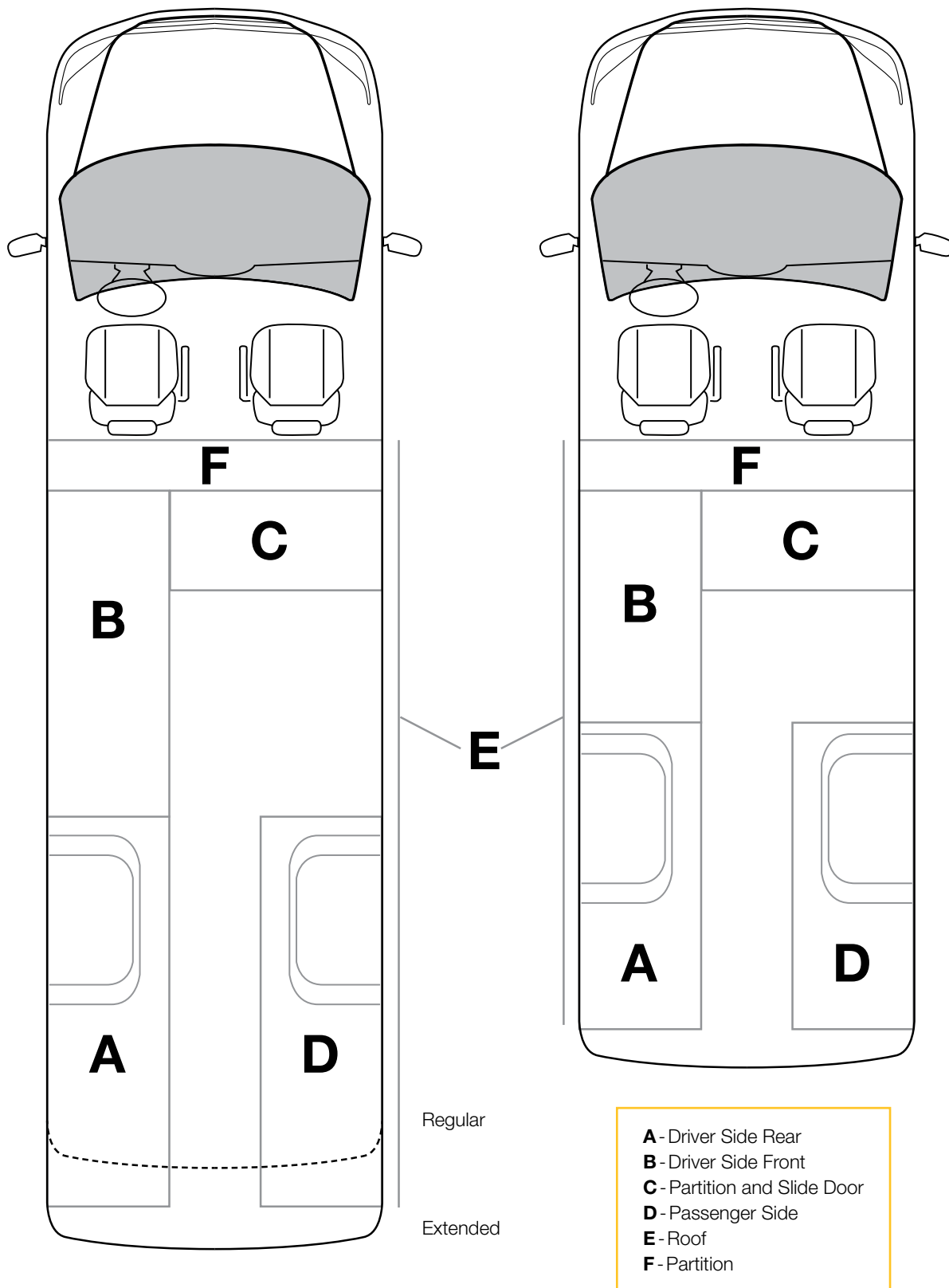

# IT'S MORE THAN A FLOOR

Ranger Design's unique flooring system with integrated aluminum mounting tracks provide a flush surface, making it easy to install a variety of Ranger Design shelving, equipment and accessories.

Ranger Designs' custom-fit rigid flooring system is available for every type of service van. Designed to provide added safety and quieter ride, these impact and puncture-resistant floors give your van a professional look.

Unique benefits of these flooring products include:

- **Economical** – because the flooring has integrated mounting tracks for the price of a regular floor
- **Safer** – due to the integrated track, improved load distribution and noise reduction
- **Improved van resale value** – durable professional looking and protects the vehicle
- **Efficient** – 3 panel floor installed in 45 minutes by one person and easy to maintain



## PROTECTION

The floor protects your vehicle and prevents damage to the factory floor.



## SAFETY

Due to the integrated track, improved load distribution and noise reduction.



## EFFICIENCY

Custom-fit easy to install by one person.



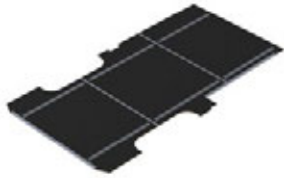

## 6540-DR

Mercedes Sprinter Floor

 144"

 86 lbs

 1 hr

 Yes

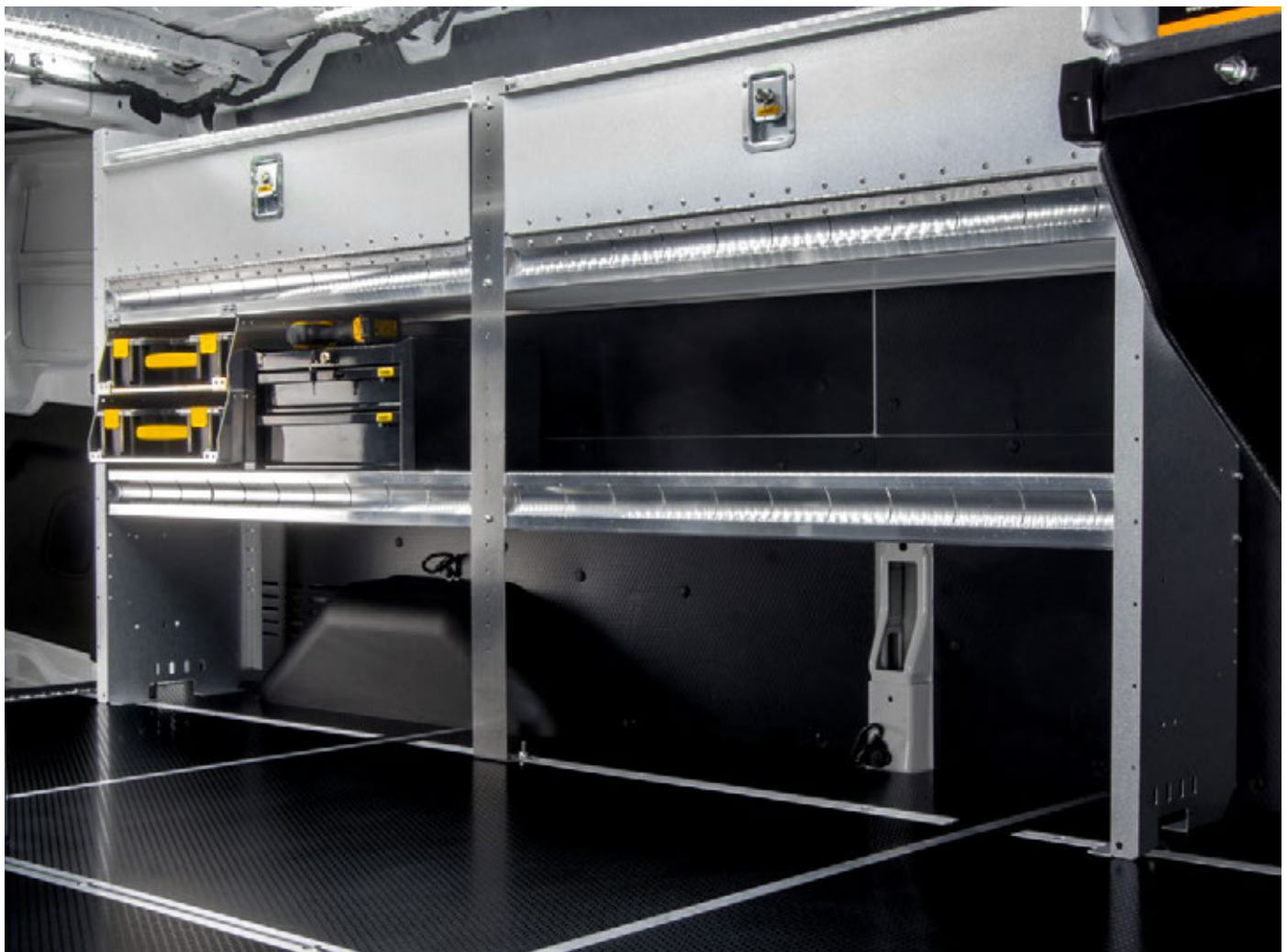
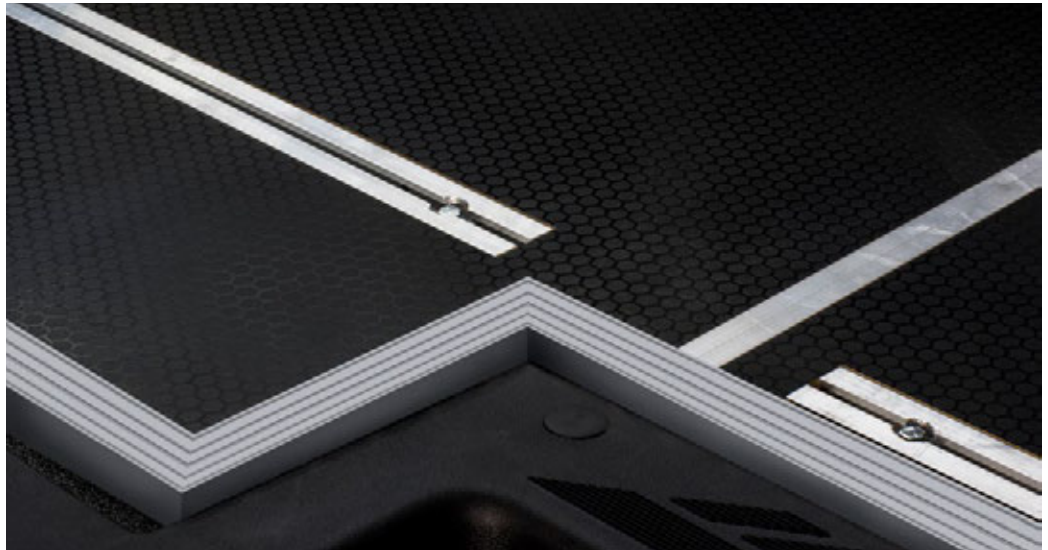

Impact and puncture resistant floors preserve the cargo van interior.



## **SAFETY PARTITIONS**

Crash tested safety partitions protect the most important asset: you



**SAFE**

Designed for maximum impact resistance.  
Proven by crash test.

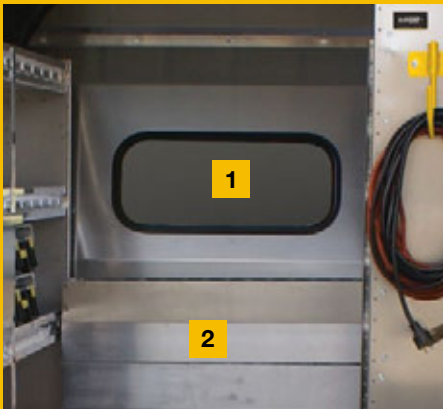

**EFFICIENT**

1. Contoured to maintain seat travel and ensure driver comfort. 2. Contoured to capitalize on cargo area floor space.



**QUIET**

Thickness of material cancels vibrations.

# SAFETY PARTITIONS

CONTOURED SAFETY PARTITION . . . . . P. 15

CONTOURED SAFETY PARTITION WITH TEMPERED WINDOW . . . . . P. 15

SINGLE SIDE STRAIGHT PARTITION . . . . . P. 16

STRAIGHT WALK THROUGH PARTITION . . . . . P. 14

STRAIGHT WALK THROUGH PARTITION WITH TEMPERED GLASS WINDOW, SWING DOOR . . . . . P. 16

Ranger Design safety partitions provide a solid and secure barrier between the occupants of the van and the cargo.

Built from heavy gauge steel and aluminum, they are designed for maximum impact resistance and uphold a standard of safety set only by Ranger products.

Ranger Design partitions also provide a more comfortable environment for the driver by giving more seat travel and by not rattling as the vehicle drives down the road.



# SAFETY PARTITIONS

PARTITIONS



## C20-DL

Straight Partition with Perforated Window, No Access

### Steel

Low Roof

80 lbs

1 hr

Yes



## C20-DH

Straight Partition with Perforated Window, No Access

### Steel

High Roof

89 lbs

1 hr

Yes



## C24-DL

Straight Walk Through Partition

### Steel

Low Roof

61 lbs

1 hr

No



## C24-DH

Straight Walk Through Partition

### Steel

High Roof

66 lbs

1 hr

No



## C30-DL

Straight Partition with Perforated Window, Swing Door

### Steel

Low Roof

83 lbs

1 hr

No



## C30-DH

Straight Partition with Perforated Window, Swing Door

### Steel

High Roof

92 lbs

1 hr

No

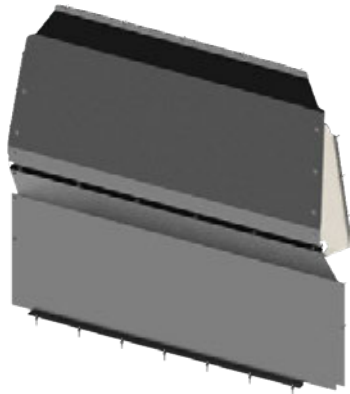

### 3010-DL

Contoured Safety Partition

Aluminum	
Low Roof	
57 lbs	
1.2 hrs	
No	

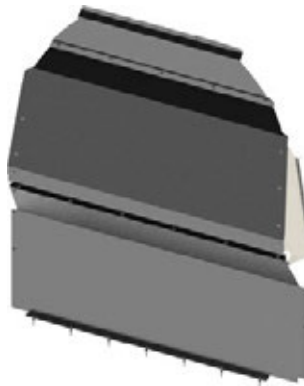

### 3010-DH

Contoured Safety Partition

Aluminum	
High Roof	
59 lbs	
1.2 hrs	
Yes	



### 3015-DH

Mid Position Straight Safety Partition

Aluminum	
High Roof	
59 lbs	
1.2 hrs	
No	



### 3020-DL

Contoured Safety Partition with Tempered Glass Window

Aluminum	
Low Roof	
64 lbs	
1.2 hrs	
No	



### 3020-DH

Contoured Safety Partition with Tempered Glass Window

Aluminum	
High Roof	
66 lbs	
1.2 hrs	
No	

## CONTOURED SAFETY PARTITIONS

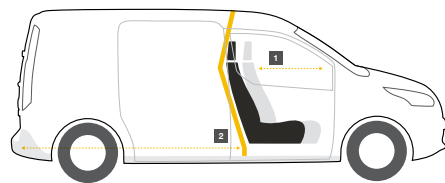

1. Contoured to maintain seat travel and ensure driver comfort.
2. Contoured to capitalize on cargo area floor space.

## SETBACK FROM B PILLAR

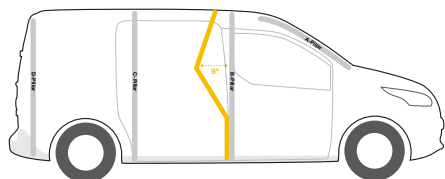

# SAFETY PARTITIONS

PARTITIONS



## 3025-DH

Mid Position Straight Safety Partition with Tempered Glass Window

### Aluminum

High Roof

66 lbs

1.2 hrs

No



## 3060-DL

Single Side Straight Partition

### Aluminum

Low Roof

20 lbs

0.7 hr

No



## 3060-DH

Single Side Straight Partition

### Aluminum

High Roof

20 lbs

0.7 hr

No



## 3064-DH

Straight Walk Through Partition

### Aluminum

High Roof

42 lbs

1 hr

No



## 3068-DL

Straight Partition with Tempered Glass Window, Sliding Door

### Aluminum

Low Roof

84 lbs

1.5 hrs

Yes



## 3068-DH

Straight Partition with Tempered Glass Window, Sliding Door

### Aluminum

High Roof

98 lbs

1.5 hrs

Yes





**3068-DH** Straight partition with tempered glass window, sliding door.



# TRADE PACKAGES

Pre-engineered packages for a broad range of trades.



**CHOICE**

A range of Fleetline and Proline packages are available for each vehicle.



**TRADE SPECIFIC**

Packages are created with the specific trades in mind. Optimized for maximum productivity.



**PERFECT FIT**

Engineered to optimize space. Layout designed to ensure that all tools are well within reach.

# TRADE PACKAGES

CONTRACTOR . . . . . P. 20

DELIVERY . . . . . P. 32

ELECTRICAL/TELECOM . . . . . P. 22

HVAC . . . . . P. 24

PLUMBER . . . . . P. 34

SERVICE . . . . . P. 26

Get more out of your work van: Ranger Design packages are designed specifically with your trade in mind. Our aim is to ensure that your most frequently used tools and equipment are well within reach.

Do you see a way that we can improve our packages? We appreciate your feedback! Contact our customer service team at **1-800-565-5321**.



# CONTRACTOR PACKAGES

PACKAGES

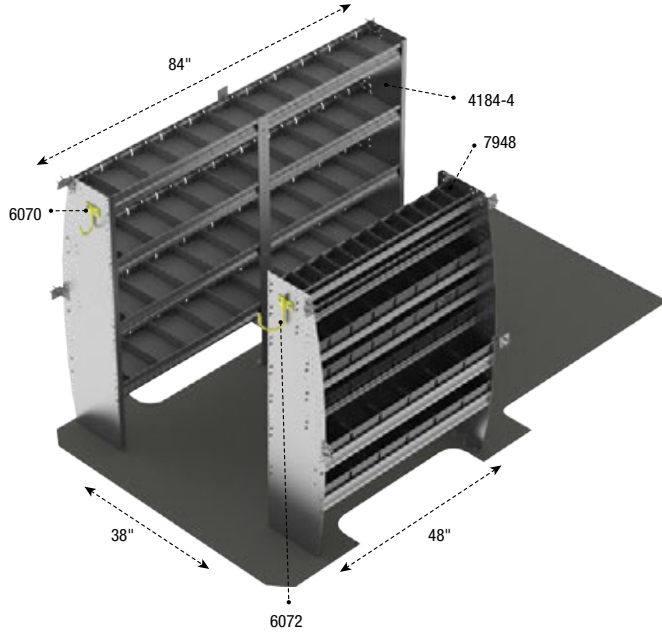

## G210 Contractor Package

**Aluminum**

144"	Low/High Roof	212 lbs
3.2 hrs	Yes	

Qty	Part #	Description
1	<b>4184-4</b>	Countoured Shelf Unit
1	<b>6070</b>	Fixed Hook
1	<b>6072</b>	Swivel Hook
1	<b>7948</b>	Countoured Bin Unit

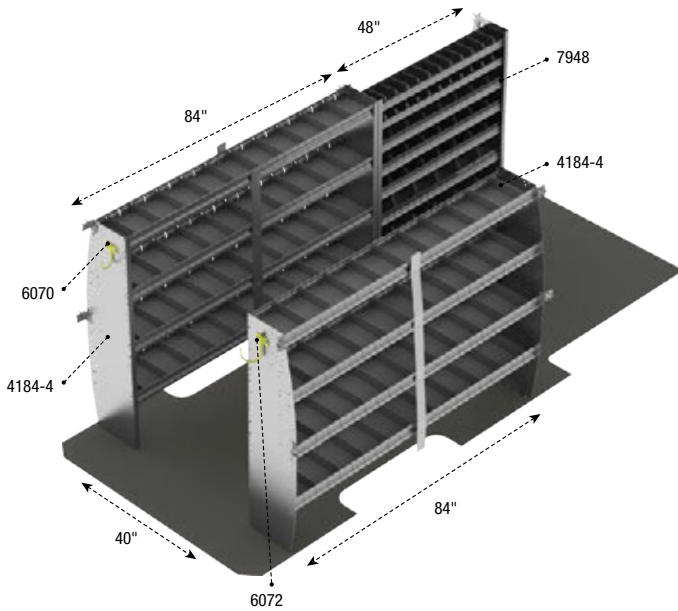

## G710 Contractor Package

**Aluminum**

170", 170" Ext	High Roof	300 lbs
4.6 hrs	Yes	

Qty	Part #	Description
2	<b>4184-4</b>	Countoured Shelf Unit
1	<b>6070</b>	Fixed Hook
1	<b>6072</b>	Swivel Hook
1	<b>7948</b>	Countoured Bin Unit

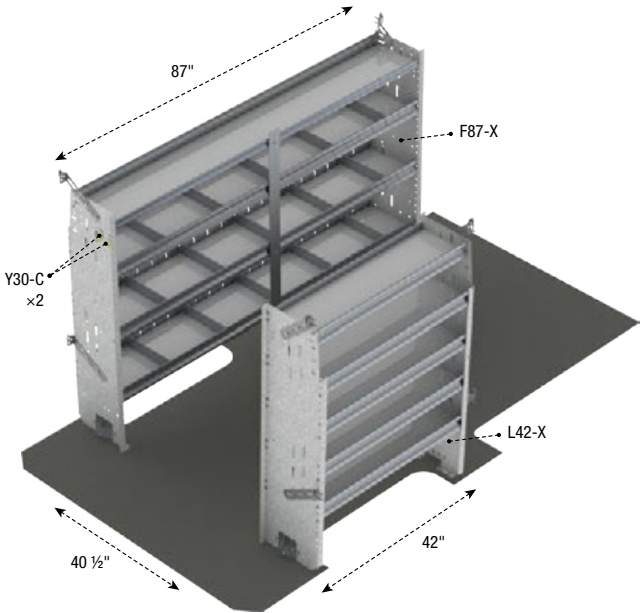

## Z10-G2 Contractor Package

**Steel**

144"	Low/High Roof	207 lbs
2.4 hrs	Yes	

Qty	Part #	Description
1	F87-X	Square Back Shelving Unit
1	L42-X	Square Back Open Shelf Unit
2	Y30-C	Coat Hook

PACKAGES

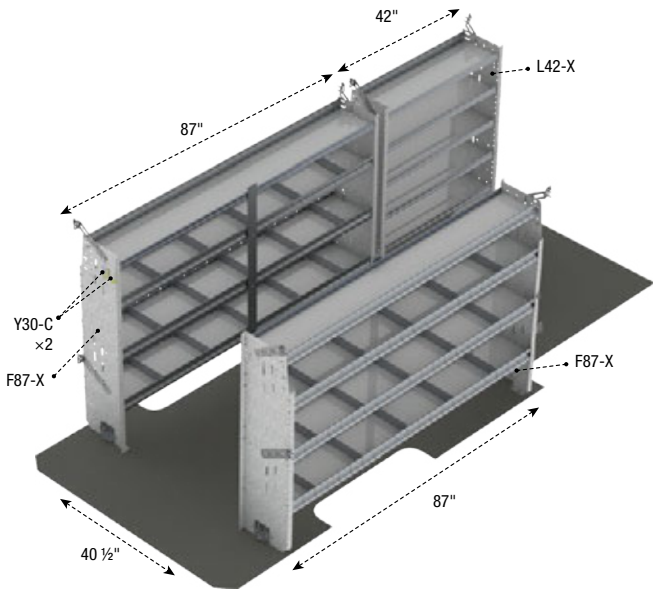

## Z10-G7 Contractor Package

**Steel**

170", 170" Ext	High Roof	332 lbs
3.4 hrs	Yes	

Qty	Part #	Description
2	F87-X	Square Back Shelving Unit
1	L42-X	Square Back Open Shelf Unit
2	Y30-C	Coat Hook

Efficient layout lets you find everything quickly and easily.



\*Preproduction model shown, do not use as an installation guide.



**EFFICIENT**

Ergonomic design reduces injuries and increases productivity.



**QUIET**

The combination of the extrusion shelf tray and end-panels create durable, vibration-free shelves.



**TOUGH**

Extrusion builds durability into shelf.

# ELECTRICAL/TELECOM PACKAGES

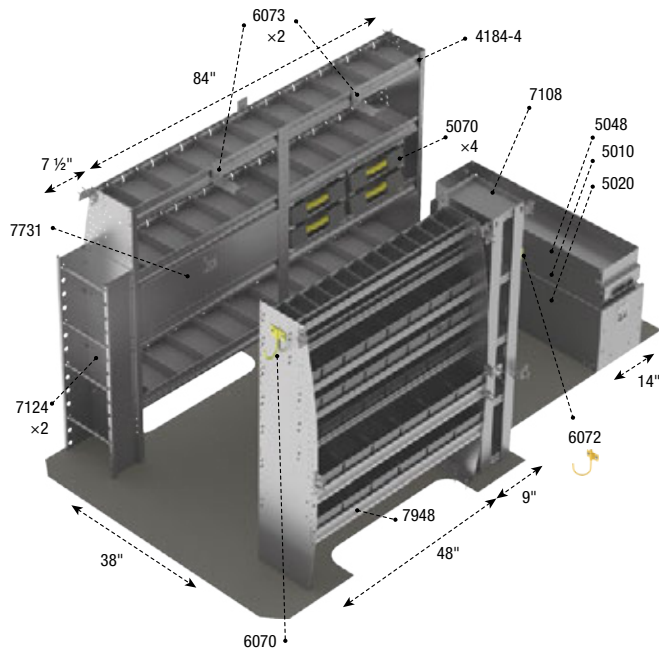

## G211 Electrical/Telecom Package

**Aluminum**

144"	Low/High Roof	379 lbs
8.1 hrs	Yes	

Qty	Part #	Description
1	4184-4	Countoured Shelf Unit
1	5010	Partslider 48" Deep
1	5020	Tool Drawers
1	5048	Top Edge
4	5070	Partskeeper
1	6070	Fixed Hook
1	6072	Swivel Hook
2	6073	Large Removable Hook
1	7108	Bookshelf
2	7124	Reel Holder
1	7731	Shelving Locker 39.875" W x 12.063" H
1	7948	Countoured Bin Unit

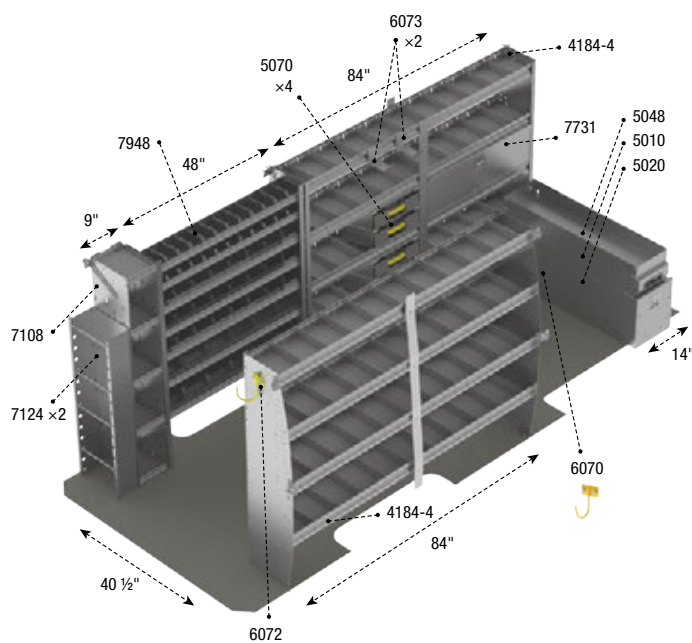

## G711 Electrical/Telecom Package

**Aluminum**

170", 170" Ext	High Roof	467 lbs
9.5 hrs	Yes	

Qty	Part #	Description
2	4184-4	Countoured Shelf Unit
1	5010	Partslider 48" Deep
1	5020	Tool Drawer
1	5048	Top Edge
4	5070	Partskeeper
1	6070	Fixed Hook
1	6072	Swivel Hook
2	6073	Large Removable Hook
1	7108	Bookshelf
2	7124	Reel Holder
1	7731	Shelving Locker 39.875" W x 12.063" H
1	7948	Countoured Bin Unit

Efficient layout lets you find everything quickly and easily.



# G212

## HVAC Package



**QUIET**  
The combination of the extrusion shelf tray and end-panels create durable, vibration-free shelves.



**EFFICIENT**  
Ergonomic design reduces injuries and increases productivity.



**TOUGH**  
Extrusion builds durability into shelf.



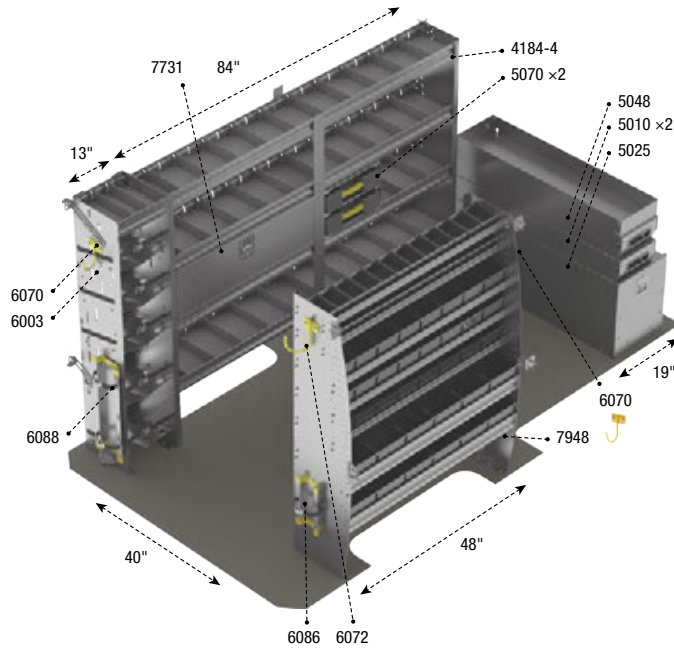

## G212 HVAC Package

**Aluminum**

144"	Low/High Roof	399 lbs
7.8 hrs	Yes	

Qty	Part #	Description
1	<b>4184-4</b>	Countoured Shelf Unit
2	<b>5010</b>	Partslider 48" Deep
1	<b>5025</b>	Jumbo Tool Drawer
1	<b>5048</b>	Top Edge
2	<b>5070</b>	Partskeeper
1	<b>6003</b>	5 Tier Freon Rack - Small & Large Bottles
2	<b>6070</b>	Fixed Hook
1	<b>6072</b>	Swivel Hook
1	<b>6086</b>	Small Bottle Holder
1	<b>6088</b>	Large Bottle Holder
1	<b>7731</b>	Shelving Locker 39.875" W x 12.063" H
1	<b>7948</b>	Countoured Bin Unit

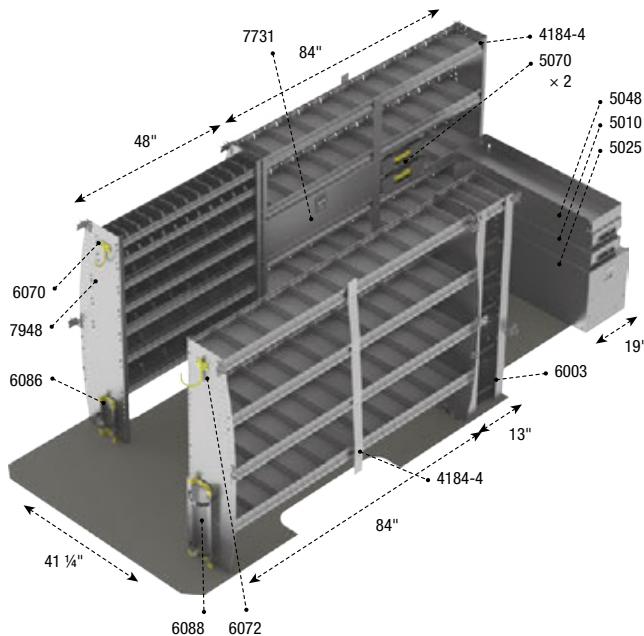

## G712 HVAC Package

**Aluminum**

170", 170" Ext	High Roof	487 lbs
9 hrs	Yes	

Qty	Part #	Description
2	<b>4184-4</b>	Countoured Shelf Unit
2	<b>5010</b>	Partslider 48" Deep
1	<b>5025</b>	Jumbo Tool Drawer
1	<b>5048</b>	Top Edge
2	<b>5070</b>	Partskeeper
1	<b>6003</b>	5 Tier Freon Rack - Small & Large Bottles
1	<b>6070</b>	Fixed Hook
1	<b>6072</b>	Swivel Hook
1	<b>6086</b>	Small Bottle Holder
1	<b>6088</b>	Large Bottle Holder
1	<b>7731</b>	Shelving Locker 39.875" W x 12.063" H
1	<b>7948</b>	Countoured Bin Unit



Efficient layout lets you find everything quickly and easily.

# G216

## Service Package

\*Preproduction model shown, do not use as an installation guide.



### QUIET

The combination of the extrusion shelf tray and end-panels create durable, vibration-free shelves.



### EFFICIENT

Ergonomic design reduces injuries and increases productivity.



### TOUGH

Extrusion builds durability into shelf.

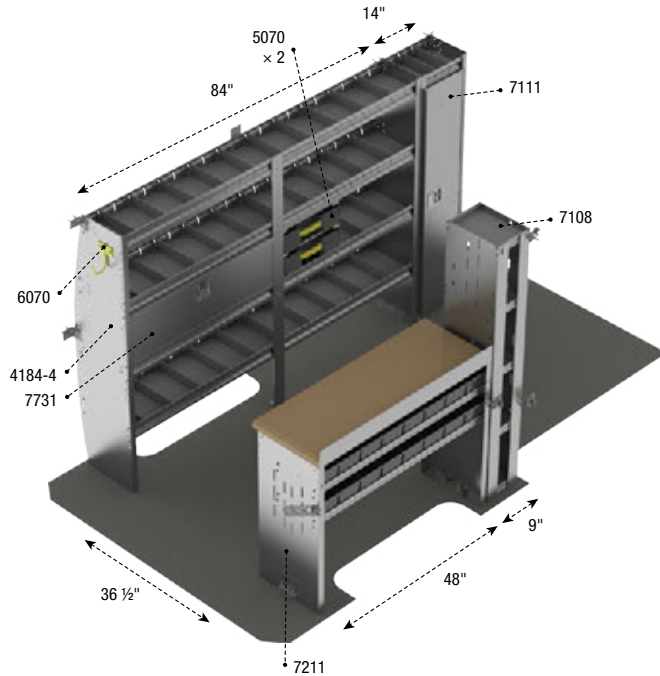

## G216

### Service Package

#### Aluminum

144"	Low/High Roof	250 lbs
5.2 hrs	Yes	

Qty	Part #	Description
1	4184-4	Countoured Shelf Unit
2	5070	Partskeeper
1	6070	Fixed Hook
1	7108	Bookshelf
1	7111	Locker Unit
1	7211	Workbench
1	7731	Aluminum Locking Door

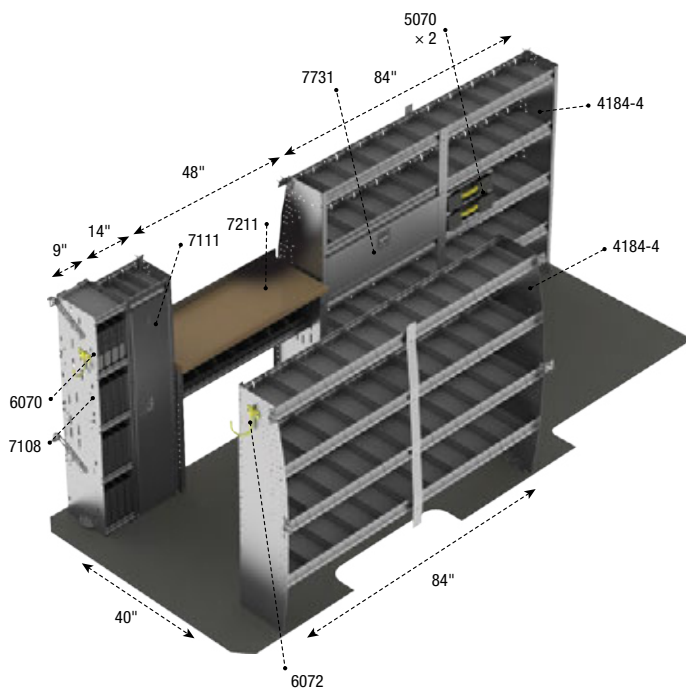

## G716

### Service Package

#### Aluminum

170", 170" Ext	High Roof	339 lbs
6.8 hrs	Yes	

Qty	Part #	Description
2	4184-4	Countoured Shelf Unit
2	5070	Partskeeper
1	6070	Fixed Hook
1	6072	Swivel Hook
1	7108	Bookshelf
1	7111	Locker Unit
1	7211	Workbench
1	7731	Shelving Locker 39.875" W x 12.063" H



Efficient layout lets you find everything quickly and easily.

# G217

## Service Package

\*Preproduction model shown, do not use as an installation guide.



**QUIET**  
The combination of the extrusion shelf tray and end-panels create durable, vibration-free shelves.



**EFFICIENT**  
Ergonomic design reduces injuries and increases productivity.



**TOUGH**  
Extrusion builds durability into shelf.

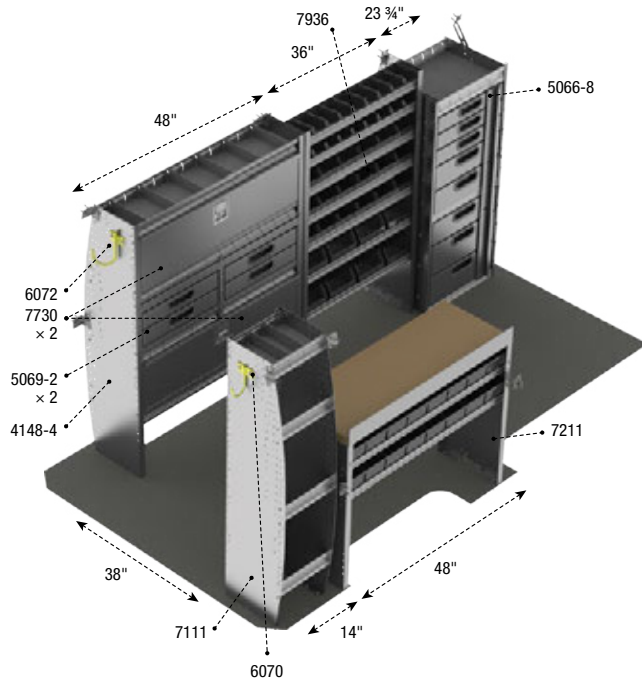

## G217 Service Package

**Aluminum**

144"	Low/High Roof	518 lbs
8 hrs	No	

Qty	Part #	Description
1	4148-4	Countoured Shelf Unit
1	5066-8	8 Drawer Cabinet
2	5069-2	2 Drawer Cabinet
1	6070	Fixed Hook
1	6072	Swivel Hook
1	7111	Locker Unit
1	7211	Workbench
2	7730	Aluminum Locking Door
1	7936	Countoured Bin Unit

PACKAGES

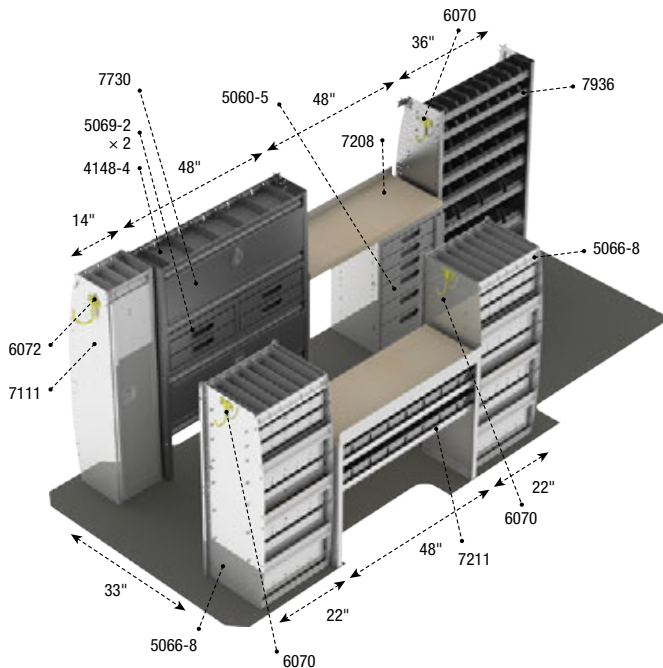

## G717 Service Package

**Aluminum**

170", 170" Ext	High Roof	838 lbs
10.9 hrs	No	

Qty	Part #	Description
1	4148-4	Countoured Shelf Unit
1	5060-5	5 Drawers + 1 Door Cabinet
2	5066-8	8 Drawer Cabinet
2	5069-2	2 Drawer Cabinet
3	6070	Fixed Hook
1	6072	Swivel Hook
1	7111	Locker Unit
1	7208	Workbench
1	7211	Workbench
2	7730	Aluminum Locking Door
1	7936	Countoured Bin Unit



\*Preproduction model shown, do not use as an installation guide.

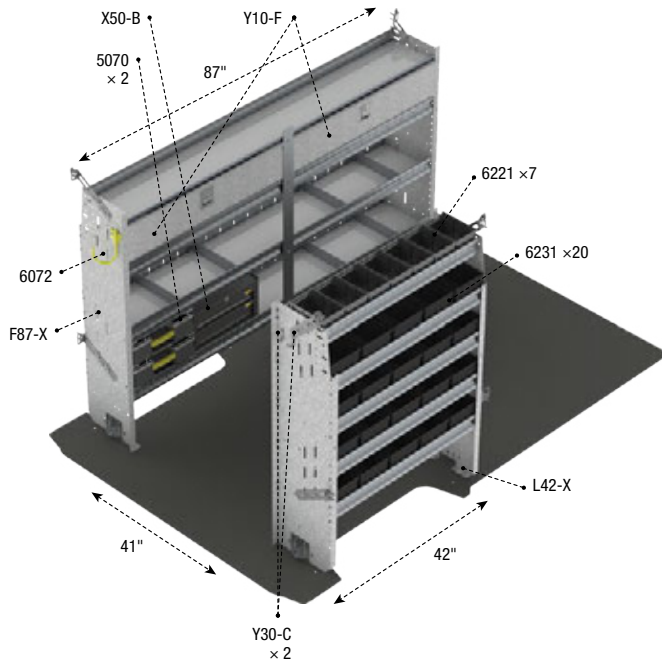

## Z16-G2 Service Package

**Steel**

144"	Low/High Roof	295 lbs
4.5 hrs	Yes	

Qty	Part #	Description
2	5070	Partskeeper
1	6072	Swivel Hook
1	L42-X	Square Back Shelving Unit
1	F87-X	Square Back Shelving Unit
1	X50-B	Fleetline 2 Drawer Unit
2	Y10-F	Y Series Locking Doors
2	Y30-C	Coat Hook
7	6221	Medium Bin - Black
20	6231	Large Bin

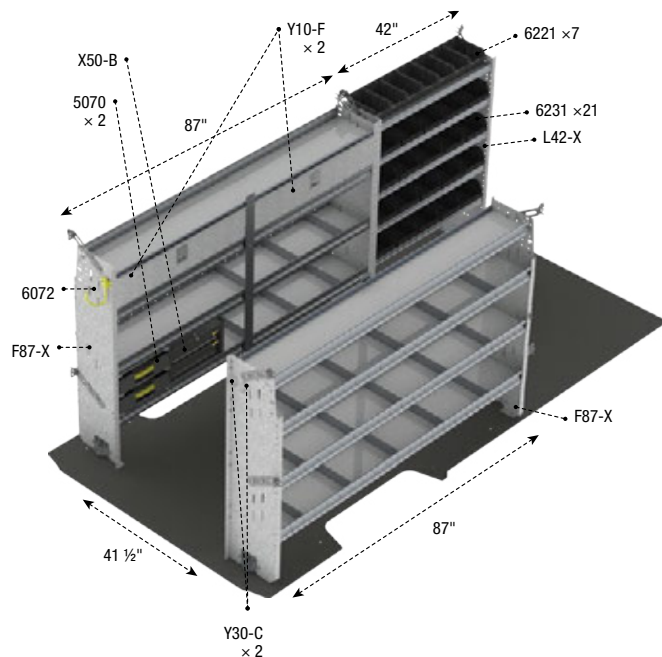

## Z16-G7 Service Package

**Steel**

170", 170" Ext	High Roof	420 lbs
5.5 hrs	Yes	

Qty	Part #	Description
2	5070	Partskeeper
1	6072	Swivel Hook
7	6221	Medium Bin - Black
20	6231	Large Bin
2	F87-X	Square Back Shelving Unit
1	L42-X	Square Back Open Shelf Unit
1	X50-B	Fleetline 2 Drawer Unit
2	Y10-F	Y Series Locking Doors
2	Y30-C	Coat Hook

Efficient layout lets you find everything quickly and easily.



# G719

## Delivery Package



### QUIET

The combination of the extrusion shelf tray and end-panels create durable, vibration-free shelves.



### EFFICIENT

Ergonomic design reduces injuries and increases productivity.



### TOUGH

Extrusion builds durability into shelf.



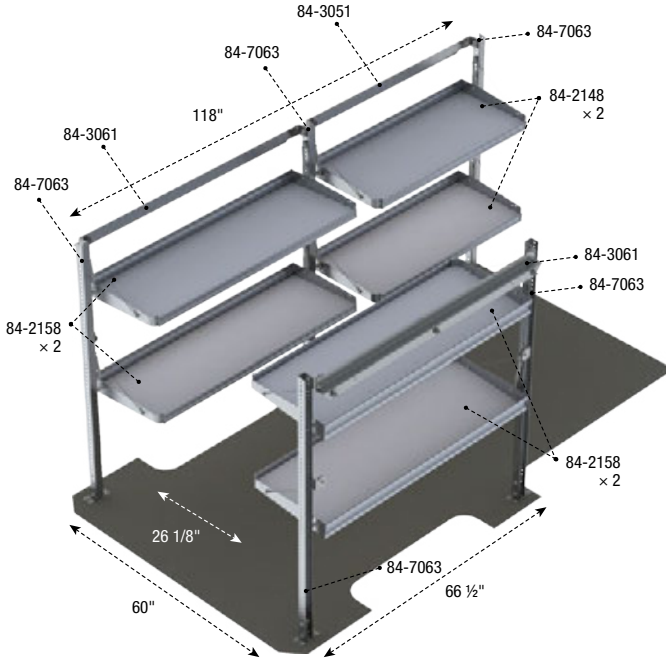

## G219 Delivery Package

### Aluminum

144"	Low/High Roof	181 lbs
3.9 hrs	Yes	

Qty	Part #	Description
2	84-2148	Shelf - Fold-Away Shelving Unit - 21" x 48"
4	84-2158	Shelf - Fold-Away Shelving Unit - 21" x 58"
1	84-3051	Mounting Bar - 51"Lg For Fold-Away Shelving Unit: 48"W
2	84-3061	Mounting Bar - 61"Lg For Fold-Away Shelving Unit: 58"W
5	84-7063	Post Assembly - Two Fold-Away Aluminum W/ Steel Foot, 63 1/2"H

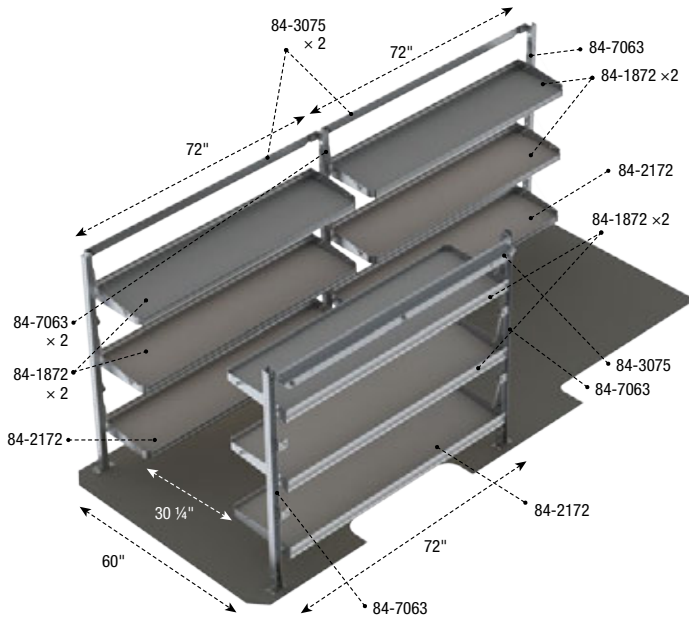

## G719 Delivery Package

### Aluminum

170", 170" Ext	High Roof	293 lbs
5.4 hrs	Yes	

Qty	Part #	Description
6	84-1872	Shelf - Fold-Away Shelving Unit - 18" x 72"
3	84-2172	Shelf - Fold-Away Shelving Unit - 21" x 72"
3	84-3075	Mounting Bar - 75"Lg For Fold-Away Shelving Unit: 72"W
5	84-7063	Post Assembly - Two Fold-Away Aluminum W/ Steel Foot, 63 1/2"H

Efficient layout lets you find everything quickly and easily.



# G215

## Plumber Package



### QUIET

The combination of the extrusion shelf tray and end-panels create durable, vibration-free shelves.



### EFFICIENT

Ergonomic design reduces injuries and increases productivity.



### TOUGH

Extrusion builds durability into shelf.

# PLUMBER PACKAGES

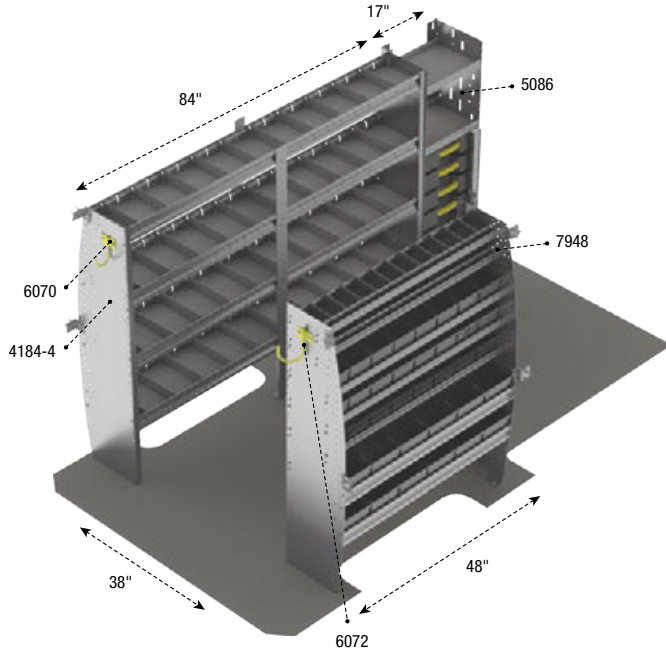

## G215 Plumber Package

**Aluminum**

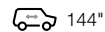

144"



Low/High Roof



269 lbs



4.2 hrs



Yes

Qty	Part #	Description
1	<b>4184-4</b>	Countoured Shelf Unit
1	<b>5086</b>	Partskeeper Cabinet With 8 Carry Cases & 2 Shelves
1	<b>6070</b>	Fixed Hook
1	<b>6072</b>	Swivel Hook
1	<b>7948</b>	Countoured Bin Unit

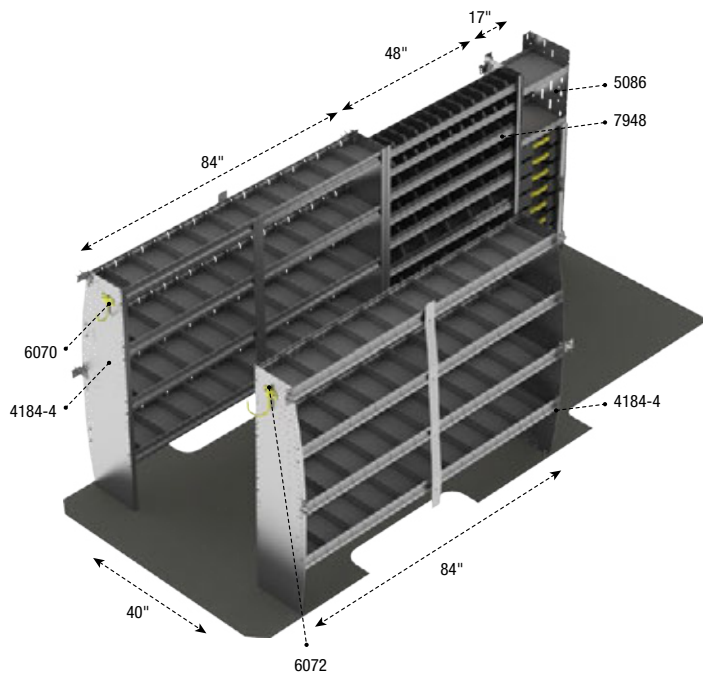

## G715 Plumber Package

**Aluminum**

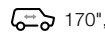

170", 170" Ext



High Roof



357 lbs



5.6 hrs



Yes

Qty	Part #	Description
2	<b>4184-4</b>	Countoured Shelf Unit
1	<b>5086</b>	Partskeeper Cabinet With 8 Carry Cases & 2 Shelves
1	<b>6070</b>	Fixed Hook
1	<b>6072</b>	Swivel Hook
1	<b>7948</b>	Countoured Bin Unit



# **SHELVING**

Industry leading strength.  
The perfect fit for the toughest jobs.



**TOUGH**

Extrusion builds durability into shelf.



**QUIET**

Shelf tray and end panel are engineered to be vibration free.

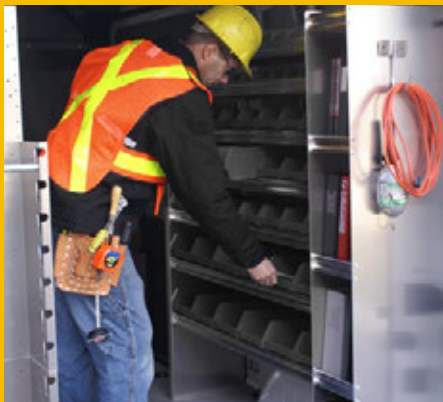

**EFFICIENT**

Ergonomics reduce injuries and increase productivity.

# SHELVING

**CONTOURED UNITS**

CONTOURED BIN SHELVING UNIT . . . . . P. 38  
 CONTOURED REFRIGERANT BIN UNIT . . . . . P. 38  
 CONTOURED SHELVING UNIT W/ DIVIDERS . . . . . P. 39  
 LOCKER . . . . . P. 47

**DEEP SQUARE BACK UNITS**

DEEP SQ. BACK BIN SHELVING UNIT . . . . . P. 42  
 DEEP SQ. BACK SHELVING UNIT . . . . . P. 42  
 DEEP SQ. BACK SHELVING UNIT W/ DIVIDERS . . . . . P. 43

**DOORS**

. . . . . P. 49

**FOLD-AWAY SHELVING**

. . . . . P. 44

**SQUARE BACK UNITS**

SQUARE BACK BIN SHELVING UNIT . . . . . P. 43  
 SQUARE BACK SHELVING UNIT . . . . . P. 45  
 SQUARE BACK SHELVING UNIT W/ DIVIDERS . . . . . P. 46  
 BOOKSHELF . . . . . P. 46  
 WORKBENCH . . . . . P. 47

Ranger Design shelving is built strong and durable, often outlasts the vehicle and can be transferred to a newer van or truck. Designed to fit with maximum efficiency, Ranger Design shelving optimizes the space in a work van's cargo area.



# SHELVING

## Contoured Bin Shelving Unit

### Aluminum



Sprinter  
Low Roof



Sprinter  
High Roof



<b>7936</b>	15.5" D x 36" W x 62.5" H	99 lbs	—	—	18 (sm), 18 (md), 8 (lrg)	1.4 hrs	No
<b>7948</b>	15.5" D x 48" W x 62.5" H	129 lbs	—	—	24 (sm), 24 (md), 12 (lrg)	1.4 hrs	Yes
<b>7960</b>	15.5" D x 60" W x 62.5" H	143 lbs	—	—	30 (sm), 30 (md), 14 (lrg)	1.4 hrs	Yes



## Contoured Bin Shelving Unit

### Aluminum



Sprinter  
High Roof



<b>8936-7</b>	15.5" D x 36" W x 72" H	100 lbs	—	—	18 (sm), 18 (md), 8 (lrg)	1.4 hrs	No
<b>8948-7</b>	15.5" D x 48" W x 72" H	124 lbs	—	—	24 (sm), 24 (md), 12 (lrg)	1.4 hrs	No
<b>8960-7</b>	15.5" D x 60" W x 72" H	144 lbs	—	—	30 (sm), 30 (md), 14 (lrg)	1.4 hrs	No



## Contoured Bin Shelving Unit

### Aluminum



Sprinter  
High Roof



<b>8936-8</b>	15.5" D x 36" W x 72" H	112 lbs	—	—	18 (sm), 18 (md), 12 (lrg)	1.4 hrs	No
<b>8948-8</b>	15.5" D x 48" W x 72" H	140 lbs	—	—	24 (sm), 24 (md), 18 (lrg)	1.4 hrs	No
<b>8960-8</b>	15.5" D x 60" W x 72" H	164 lbs	—	—	30 (sm), 30 (md), 21 (lrg)	1.4 hrs	No



## Contoured Refrigerant Bin Unit

### Aluminum



Sprinter  
Low Roof



Sprinter  
High Roof



<b>5748</b>	16" D x 48" W x 62.5" H	106 lbs	—	—	24 (sm), 24 (md)	1.2 hrs	No
<b>5760</b>	16" D x 60" W x 62.5" H	120 lbs	—	—	30 (sm), 30 (md)	1.2 hrs	No



## Contoured Refrigerant Bin Unit

### Aluminum



Sprinter  
High Roof



<b>8748</b>	15.5" D x 48" W x 72" H	107 lbs	—	—	24 (sm), 24 (md)	1.4 hrs	No
<b>8760</b>	15.5" D x 60" W x 72" H	121 lbs	—	—	30 (sm), 30 (md)	1.4 hrs	No



## Contoured Shelving Unit with Dividers

### Aluminum



Sprinter  
Low Roof



Sprinter  
High Roof



<b>4136-4</b>	16" D x 36" W x 62.5" H	46 lbs	4 Shelves (10", 11", 13", 13")	24	7733	1.2 hrs	No
<b>4148-4</b>	16" D x 48" W x 62.5" H	56 lbs	4 Shelves (10", 11", 13", 13")	24	7730	1.2 hrs	Yes



## Contoured Shelving Unit with Dividers

### Aluminum



Sprinter  
Low Roof



Sprinter  
High Roof



<b>4136-5</b>	16" D x 36" W x 62.5" H	53 lbs	5 Shelves (10", 11", 13", 13", 13")	30	7728	1.2 hrs	No
<b>4148-5</b>	16" D x 48" W x 62.5" H	65 lbs	5 Shelves (10", 11", 13", 13", 13")	30	7725	1.2 hrs	No
<b>4160-5</b>	16" D x 60" W x 62.5" H	78 lbs	5 Shelves (10", 11", 13", 13", 13")	40	7727	1.2 hrs	Yes



## Contoured Shelving Unit with Dividers

### Aluminum



Sprinter  
Low Roof



Sprinter  
High Roof



<b>4172-4</b>	16" D x 72" W x 62.5" H	76 lbs	4 Shelves (10", 11", 13", 13")	40	7733	1.4 hrs	No
<b>4184-4</b>	16" D x 84" W x 62.5" H	88 lbs	4 Shelves (10", 11", 13", 13")	40	N/A	1.4 hrs	Yes
<b>4196-4</b>	16" D x 96" W x 62.5" H	98 lbs	4 Shelves (10", 11", 13", 13")	48	7730	1.4 hrs	Yes



# SHELVING

## Contoured Shelving Unit with Dividers

### Aluminum



Sprinter  
Low Roof



Sprinter  
High Roof



<b>4172-5</b>	16" D x 72" W x 62.5" H	90 lbs	5 Shelves (10", 11", 13", 13", 13")	50	7728	1.4 hrs	No
<b>4184-5</b>	16" D x 84" W x 62.5" H	102 lbs	5 Shelves (10", 11", 13", 13", 13")	50	N/A	1.4 hrs	Yes
<b>4196-5</b>	16" D x 96" W x 62.5" H	118 lbs	5 Shelves (10", 11", 13", 13", 13")	60	7725	1.4 hrs	No



## Contoured Shelving Unit with Dividers

### Aluminum



Sprinter  
High Roof



<b>8848-5</b>	15.5" D x 48" W x 72" H	66 lbs	5 Shelves (8", 11", 12", 13", 13")	30	7725	1.3 hrs	No
<b>8860-5</b>	15.5" D x 60" W x 72" H	79 lbs	5 Shelves (8", 11", 12", 13", 13")	40	7727 or 7732	1.3 hrs	No



## Contoured Shelving Unit with Dividers

### Aluminum



Sprinter  
High Roof



<b>8848-6</b>	15.5" D x 48" W x 72" H	75 lbs	6 Shelves (8", 11", 12", 13", 13", 13")	36	7720	1.3 hrs	No
<b>8860-6</b>	15.5" D x 60" W x 72" H	91 lbs	6 Shelves (8", 11", 12", 13", 13", 13")	48	7722	1.3 hrs	No



## Contoured Shelving Unit with Dividers

### Aluminum



Sprinter  
High Roof



<b>8872-5</b>	15.5" D x 72" W x 72" H	91 lbs	5 Shelves (8", 11", 12", 13", 13")	40	7728	1.3 hrs	No
<b>8884-5</b>	15.5" D x 84" W x 72" H	103 lbs	5 Shelves (8", 11", 12", 13", 13")	50	N/A	1.3 hrs	No
<b>8896-5</b>	15.5" D x 96" W x 72" H	119 lbs	5 Shelves (8", 11", 12", 13", 13")	60	7725	1.3 hrs	No





# FULLY OPTIMIZE SPACE IN YOUR HIGH ROOF VAN

## RANGER DESIGN Tall shelving

- › Contoured to fit tightly to the wall of the vehicle to maximize aisle space

84 series p.**44**  
87 series p.**39**  
88 series p.**40**  
89 series p.**38**

## COMPETITOR Shelving

- › Shorter
- › Not fitted to the wall of the vehicle, reducing aisle space

## RANGER DESIGN Regular shelving

- › Contoured to fit tightly to the wall of the vehicle to maximize aisle space

F series p.**43-46**  
41 series p.**39**  
57 series p.**38**  
79 series p.**38**  
84-2 series p.**44**

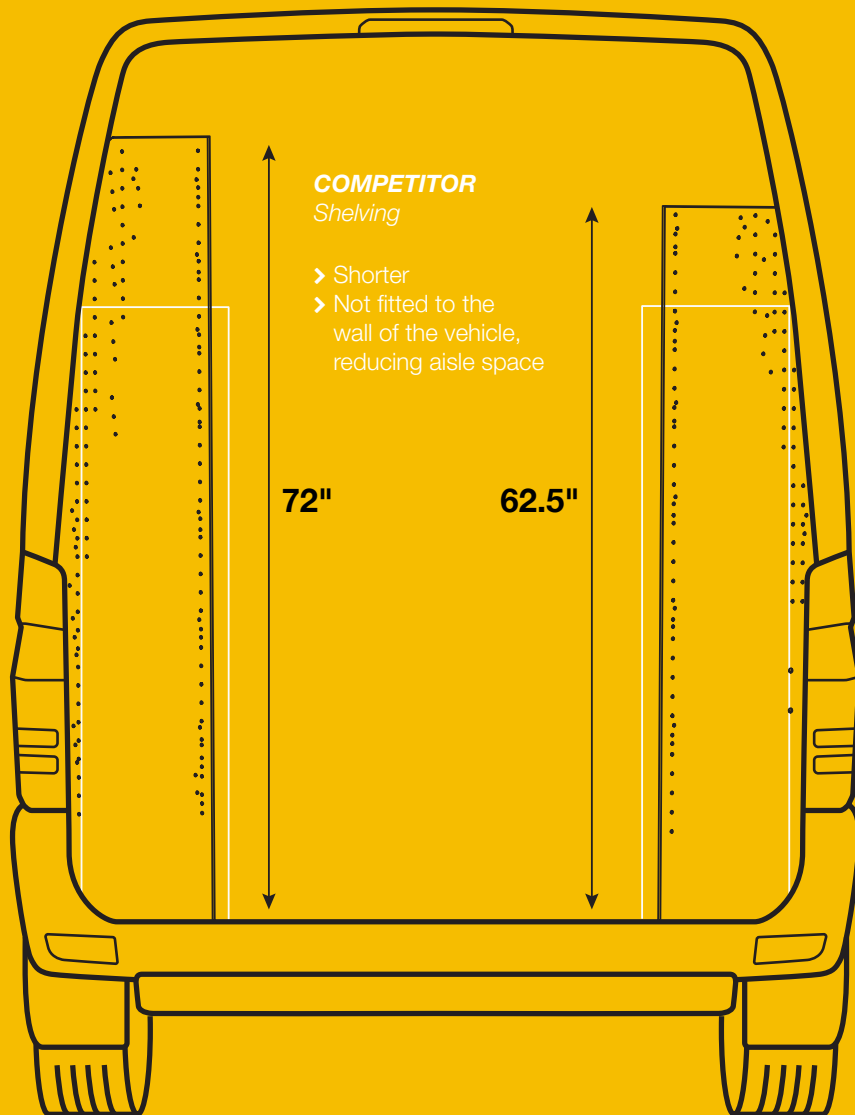

# SHELVING

## Contoured Shelving Unit with Dividers

### Aluminum



Sprinter High Roof



<b>8872-6</b>	15.5" D x 72" W x 72" H	105 lbs	6 Shelves (8", 11", 12", 13", 13", 13")	48	7723	1.3 hrs	No
<b>8884-6</b>	15.5" D x 84" W x 72" H	117 lbs	6 Shelves (8", 11", 12", 13", 13", 13")	60	N/A	1.3 hrs	No
<b>8896-6</b>	15.5" D x 96" W x 72" H	139 lbs	6 Shelves (8", 11", 12", 13", 13", 13")	72	7720	1.3 hrs	No



## Deep Square Back Bin Shelving Unit

### Steel



Sprinter Low Roof



Sprinter High Roof



<b>H38-T</b>	17.5" D x 38" W x 58" H	93 lbs	—	—	Y11-D	1 hr	No
<b>H42-T</b>	17.5" D x 42" W x 58" H	100 lbs	—	—	Y11-F	1 hr	No
<b>H56-T</b>	17.5" D x 56" W x 58" H	120 lbs	—	—	Y11-J	1 hr	No
<b>H70-T</b>	17.5" D x 70" W x 58" H	140 lbs	—	—	Y11-C	1 hr	No

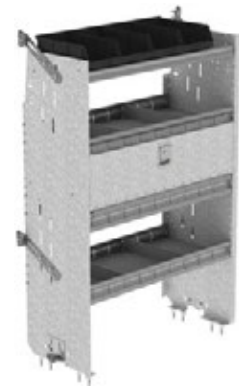

## Deep Square Back Bin Shelving Unit

### Steel



Sprinter Low Roof



Sprinter High Roof



<b>H87-T</b>	17.5" D x 87" W x 58" H	165 lbs	—	—	Y11-F	1 hr	No
--------------	-------------------------	---------	---	---	-------	------	----



## Deep Square Back Shelving Unit

### Steel



Sprinter Low Roof



Sprinter High Roof





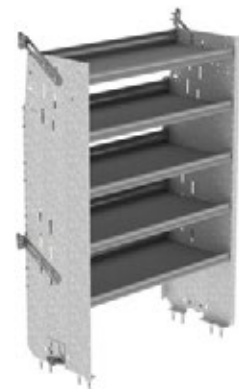





<b>L38-T</b>	17.5" D x 38" W x 58" H	88 lbs	—	—	Y10-D	1 hr	No
<b>L42-T</b>	17.5" D x 42" W x 58" H	93 lbs	—	—	Y10-F	1 hr	No
<b>L56-T</b>	17.5" D x 56" W x 58" H	112 lbs	—	—	Y10-B	1 hr	No
<b>L70-T</b>	17.5" D x 70" W x 58" H	130 lbs	—	—	Y10-C	1 hr	No



## Deep Square Back Shelving Unit







**Steel**

								
Sprinter Low Roof	Sprinter High Roof	17.5" D x 87" W x 58" H	154 lbs	—	—	Y10-F	1 hr	No



## Square Back Bin Shelving Unit









**Aluminum**

						
11" D x 48" W x 13.25" H	25 lbs	2 Shelves (9", 9")	—	16 (md)	0.5 hr	No



## Deep Square Back Shelving Unit with Dividers





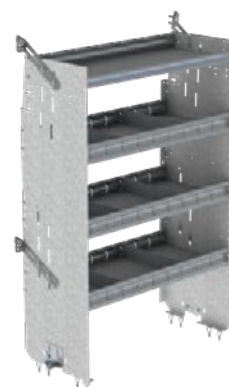



**Steel**

								
Sprinter Low Roof	Sprinter High Roof	17.5" D x 38" W x 58" H	80 lbs	4 Shelves (14", 16", 16", 16")	6	Y11-D	1 hr	No
		17.5" D x 42" W x 58" H	85 lbs	4 Shelves (14", 16", 16", 16")	6	Y11-F	1 hr	Yes
		17.5" D x 56" W x 58" H	101 lbs	4 Shelves (14", 16", 16", 16")	12	Y11-J	1 hr	Yes
		17.5" D x 70" W x 58" H	115 lbs	4 Shelves (14", 16", 16", 16")	12	Y11-C	1 hr	No



## Deep Square Back Shelving Unit with Dividers

**Steel**

								
Sprinter Low Roof	Sprinter High Roof	17.5" D x 87" W x 58" H	136 lbs	4 Shelves (14", 16", 16", 16")	15	Y11-F	1 hr	Yes

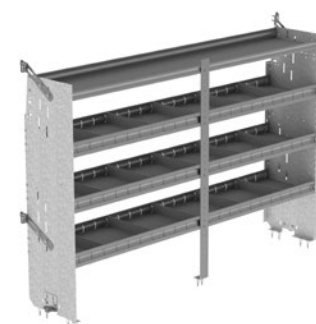

**LEGEND**

 Dimensions  Weight  Shelf opening  Dividers  Bins  Install Time  Quickship

# SHELVING

## Fold-Away Shelving

### Aluminum



Sprinter  
Low Roof



Sprinter  
High Roof



Part Number	Dimensions (D x W x H)	Weight	Shelves	Shelves (W)	Time	Yes/No
8436-2	21" D x 43" W x 63.5" H	42 lbs	2 Shelves	(20", 20")	2.2 hrs	No
8448-2	21" D x 55" W x 63.5" H	58 lbs	2 Shelves	(20", 20")	2.2 hrs	Yes
8458-2	21" D x 65" W x 63.5" H	64 lbs	2 Shelves	(20", 20")	2.3 hrs	Yes
8472-2	21" D x 79" W x 63.5" H	74 lbs	2 Shelves	(20", 20")	2.4 hrs	Yes

\*Weight capacity for fold-away shelving is 65 lbs / linear foot.



## Fold-Away Shelf Tray with Gas Shocks and Hardware

### Aluminum



Part Number	Dimensions (D x W)	Weight	Depth	Shelves	Shelves (W)	Time	Yes/No
84-1830	18" D x 30" W	15 lbs	17"	—	—	0.4 hr	No
84-1836	18" D x 36" W	17 lbs	17"	—	—	0.4 hr	Yes
84-1848	18" D x 48" W	21 lbs	17"	—	—	0.4 hr	No
84-1858	18" D x 58" W	21 lbs	17"	—	—	0.4 hr	No
84-1872	18" D x 72" W	26 lbs	17"	—	—	0.44 hr	Yes
84-2130	21" D x 30" W	16 lbs	20"	—	—	0.4 hr	No
84-2136	21" D x 36" W	17 lbs	20"	—	—	0.4 hr	Yes
84-2148	21" D x 48" W	20 lbs	20"	—	—	0.4 hr	Yes
84-2158	21" D x 58" W	23 lbs	20"	—	—	0.4 hr	Yes
84-2172	21" D x 72" W	30 lbs	20"	—	—	0.4 hr	Yes

\*Weight capacity for fold-away shelving is 65 lbs / linear foot.



## Fold-Away Shelving

### Aluminum



Sprinter  
High Roof



Part Number	Dimensions (D x W x H)	Weight	Shelves	Shelves (W)	Time	Yes/No
8448-3	21" D x 55" W x 72" H	74 lbs	3 Shelves	(17", 17", 20")	2.5 hrs	No
8458-3	21" D x 65" W x 72" H	83 lbs	3 Shelves	(17", 17", 20")	2.7 hrs	Yes
8472-3	21" D x 79" W x 72" H	98 lbs	3 Shelves	(17", 17", 20")	2.7 hrs	Yes

\*Weight capacity for fold-away shelving is 65 lbs / linear foot.



## Mounting Bar Assembly for Fold-Away Shelving

### Aluminum



Part Number	Dimensions (D x W)	Weight	Depth	Shelves	Shelves (W)	Time	Yes/No
84-3033	2" D x 33" W	3 lbs	—	—	—	0.5 hr	No
84-3039	2" D x 39" W	3 lbs	—	—	—	0.5 hr	Yes
84-3051	2" D x 51" W	6 lbs	—	—	—	0.5 hr	Yes
84-3061	2" D x 61" W	5 lbs	—	—	—	0.5 hr	Yes
84-3075	2" D x 75" W	6 lbs	—	—	—	3 hrs	Yes

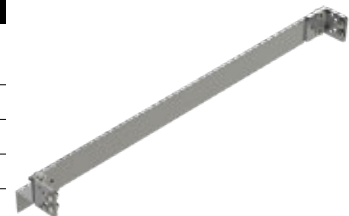

## Mounting Bar Assembly for Fold-Away Shelving

### Aluminum

<b>84-7063</b>	2" D x 2" W x 63.5" H	8 lbs	—	—	—	0.2 hr	Yes



## Square Back Bin Shelving Unit

### Steel

	Sprinter Low Roof	Sprinter High Roof							
<b>H38-X</b>	14" D x 38" W x 58" H	80 lbs	4 Shelves (9", 13", 13", 13")	9	6	1 hr	No		
<b>H42-X</b>	14" D x 42" W x 58" H	86 lbs	4 Shelves (9", 13", 13", 13")	9	7	1 hr	No		
<b>H56-X</b>	14" D x 56" W x 58" H	103 lbs	4 Shelves (9", 13", 13", 13")	12	9	1 hr	No		
<b>H70-X</b>	14" D x 70" W x 58" H	120 lbs	4 Shelves (9", 13", 13", 13")	12	11	1 hr	No		



## Square Back Bin Shelving Unit

### Steel

	Sprinter Low Roof	Sprinter High Roof							
<b>H87-X</b>	14" D x 87" W x 58" H	145 lbs	4 Shelves (9", 13", 13", 13")	18	14	1 hr	No		



## Square Back Shelving Unit

### Steel

	Sprinter Low Roof	Sprinter High Roof							
<b>L38-X</b>	14" D x 38" W x 58" H	78 lbs	5 Shelves (11", 13", 13", 13", 13")	—	—	1 hr	Yes		
<b>L42-X</b>	14" D x 42" W x 58" H	82 lbs	5 Shelves (11", 13", 13", 13", 13")	—	—	1 hr	Yes		
<b>L56-X</b>	14" D x 56" W x 58" H	99 lbs	5 Shelves (11", 13", 13", 13", 13")	—	—	1 hr	Yes		
<b>L70-X</b>	14" D x 70" W x 58" H	115 lbs	5 Shelves (11", 13", 13", 13", 13")	—	—	1 hr	No		



# SHELVING

## Square Back Shelving Unit

**Steel**



Sprinter  
Low Roof



Sprinter  
High Roof



<b>L87-X</b>	14" D x 87" W x 58" H	141 lbs	5 Shelves (11", 13", 13", 13", 13")	—	—	1 hr	No
--------------	-----------------------	---------	-------------------------------------	---	---	------	----



## Square Back Shelving Unit with Dividers

**Steel**



Sprinter  
Low Roof



Sprinter  
High Roof



<b>F38-X</b>	14" D x 38" W x 58" H	70 lbs	4 Shelves (9", 13", 13", 13")	9	Y12-D	1 hr	No
<b>F42-X</b>	14" D x 42" W x 58" H	74 lbs	4 Shelves (9", 13", 13", 13")	9	Y12-F	1 hr	Yes
<b>F56-X</b>	14" D x 56" W x 58" H	88 lbs	4 Shelves (9", 13", 13", 13")	12	Y12-J	1 hr	Yes
<b>F70-X</b>	14" D x 70" W x 58" H	102 lbs	4 Shelves (9", 13", 13", 13")	12	Y12-C	1 hr	Yes

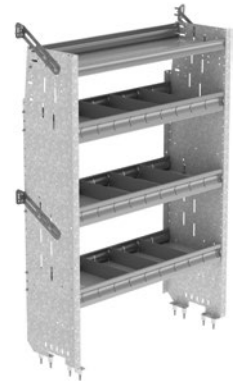

## Square Back Shelving Unit with Dividers

**Steel**



Sprinter  
Low Roof



Sprinter  
High Roof



<b>F87-X</b>	14" D x 87" W x 58" H	144 lbs	4 Shelves (9", 13", 13", 13")	18	Y12-F	1 hr	Yes
--------------	-----------------------	---------	-------------------------------	----	-------	------	-----



## Bookshelf

**Aluminum**



Sprinter  
Low Roof



Sprinter  
High Roof



<b>7108</b>	14" D x 9" W x 62.5" H	30 lbs	—	—	—	0.5 hr	Yes
-------------	------------------------	--------	---	---	---	--------	-----



## 7111

Contoured locker w/top shelf

**Aluminum**



Sprinter



16" D x 14" W x 62.5" H



39 lbs



1 hr



Yes

## 7209

Workbench w/hardwood top,  
1 shelf

**Aluminum**

Universal



18" D x 48" W x 36" H



74 lbs



1 hr



Yes

## 7207

Workbench w/hardwood top,  
no shelves

**Aluminum**

Universal



18" D x 48" W x 36" H



62 lbs



0.5 hr



No

## 7210

Workbench w/hardwood top, 1  
shelf w/door

**Aluminum**

Universal



18" D x 48" W x 36" H



75 lbs



1.2 hrs



No

## 7208

Workbench w/hardwood top,  
one end panel  
(Drawer cabinet not included)

**Aluminum**

Universal



18" D x 48" W x 36" H



47 lbs



0.5 hr



No

## 7211

Workbench w/hardwood top, 2  
bin shelves

**Aluminum**

Universal



18" D x 48" W x 36" H



92 lbs



1 hr



Yes



# SHELVING

## 7247

Workbench w/hardwood top, one end panel  
(Drawer cabinet not included)

**Aluminum**

Universal



18" D x 48" W x 28" H



47 lbs



1 hr



No

## K48-X

Square back unit with 1 open shelf, 1 workbench & 1 pull out drawer

**Steel**



Sprinter



14" D x 48" W x 58" H



105 lbs



1 hr



No

## 7248

Workbench w/hardwood top, 2 bin shelves

**Aluminum**

Universal



18" P x 48" W x 28" H



91 lbs



1 hr



Yes

## J48-X

Square back unit with 1 open shelf & 1 workbench

**Steel**



Sprinter



14" D x 48" W x 58" H



85 lbs



1 hr



No



**7208** Workbench with hardwood top mounted with a **5060-5** 5 Drawer cabinet





Shelving Doors

Aluminum					
		Use with shelf width			
7720	44.88" W x 8.69" H	48", 96"	8 lbs	0.5 hr	No
7722	56.88" W x 8.69" H	60"	9 lbs	0.5 hr	No
7723	32.88" W x 8.69" H	36", 72"	6 lbs	0.5 hr	No
7724	20.88" W x 8.69" H	24"	4 lbs	0.5 hr	No
7725	44.88" W x 10.38" H	48", 96"	8 lbs	0.5 hr	Yes
7727	56.88" W x 10.38" H	60"	9 lbs	0.5 hr	No
7728	32.88" W x 10.38" H	36", 72"	6.5 lbs	0.5 hr	Yes
7729	20.88" W x 10.38" H	24"	4 lbs	0.5 hr	No
7730	44.88" W x 12.06" H	48", 96"	10 lbs	0.5 hr	Yes
7731	38.88" W x 12.06" H	84"	8 lbs	0.5 hr	No
7732	56.88" W x 12.06" H	60"	10 lbs	0.5 hr	No
7733	32.88" W x 12.06" H	36", 72"	6 lbs	0.5 hr	Yes
7734	20.88" W x 12.06" H	24"	5 lbs	0.5 hr	No
7735	44.88" W x 13.75" H	48", 96"	11 lbs	0.5 hr	No
7737	56.88" W x 13.75" H	60"	13 lbs	0.5 hr	No
7738	32.88" W x 13.75" H	36", 72"	7 lbs	0.5 hr	No
7739	20.88" W x 13.75" H	24"	5 lbs	0.5 hr	No

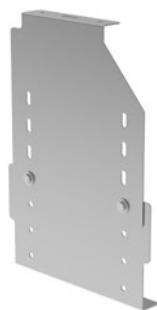

Shelf Block

*Closes the space behind shelving doors*

Aluminum					
		Use with shelf width			
7740	12" W x From 11" to 16.5", adjustable	All	3 lbs	0.5 hr	No



Shelving Doors

Steel					
		Use with shelf width			
Y10-C	34.88" W x 8.69" H	70"	8 lbs	0.5 hr	Yes
Y10-D	37.88" W x 8.69" H	38"	10 lbs	0.5 hr	No
Y10-F	41.88" W x 8.69" H	42", 87"	9 lbs	0.5 hr	Yes
Y10-H	47.88" W x 8.69" H	48"	14 lbs	0.5 hr	No
Y10-M	31.88" W x 8.69" H	32"	8 lbs	0.5 hr	No
Y11-C	34.88" W x 10.38" H	70"	10 lbs	0.5 hr	Yes
Y11-D	37.88" W x 10.38" H	38"	10 lbs	0.5 hr	Yes
Y11-E	35.88" W x 10.38" H	36"	10.5 lbs	0.5 hr	No
Y11-F	41.88" W x 10.38" H	42", 87"	13 lbs	0.5 hr	Yes
Y11-M	31.88" W x 10.38" H	32"	8 lbs	0.5 hr	No
Y12-C	34.88" W x 12.06" H	70"	10 lbs	0.5 hr	No
Y12-D	37.88" W x 12.06" H	38"	12 lbs	0.5 hr	No
Y12-F	47.88" W x 12.06" H	42", 87"	11 lbs	0.5 hr	No
Y12-M	31.88" W x 12.06" H	32"	8 lbs	0.5 hr	No



Shelving Doors

Steel					
		Use with shelf width			
Y10-J	55.88" W x 8.69" H	56"	15 lbs	0.5 hr	No
Y11-J	55.88" W x 10.38" H	56"	16 lbs	0.5 hr	No
Y12-J	55.88" W x 12.06" H	56"	17 lbs	0.5 hr	No



# DRAWERS

Durable storage compartments, designed for quick and easy access.

- AXESS TRAY . . . . . P. 51
- COMPACT DRAWERS . . . . . P. 55
- DRAWER CABINETS . . . . . P. 54
- PARTSKEEPERS . . . . . P. 55
- PARTSKEEPER CABINET . . . . . P. 44
- PARTSLIDERS . . . . . P. 55
- TOOL DRAWERS . . . . . P. 57

Ranger manufactures a variety of tough, quiet drawer systems and storage modules. Using top quality components such as full-extension, high-capacity ball-bearing drawer slides, secure locks, and Ranger's unique braided stainless steel cable-pull handles. These drawers are the organizational quality that you deserve.

If you never again want to experience the frustration of drawers that jam, sag, and don't latch properly, we have the solution.



**TOUGH**  
Proline drawers are backed by a 10 year warranty.



**QUICK**  
Easy to use slam latch.



**SECURITY**  
Secure keyed lock.



### 5032-0

Axess Tray with 1 shelf / no drawers

#### Aluminum

38" D x 45" W x 30" H

—

51 lbs

0.9 hr

No



### 5032-1

Axess Tray with 1 shelf / 1 drawer

#### Aluminum

38" D x 45" W x 30" H

200 lbs

89 lbs

1 hr

Yes



### 5032-2

Axess Tray with 1 shelf / 2 drawers

#### Aluminum

38" D x 45" W x 30" H

200 lbs

127 lbs

1.1 hrs

No



### 5032-3

Axess Tray with 1 shelf / 3 drawers

#### Aluminum

38" D x 45" W x 30" H

200 lbs

165 lbs

1.2 hrs

No



### 5032-A

Axess Tray drawer only, complete with slides

#### Aluminum

38" D x 45" W

—

38 lbs

—

No

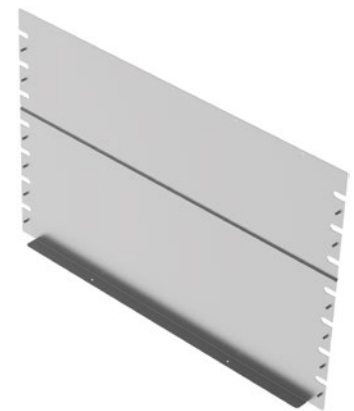

### 5032-F

Axess Tray full back panel for 5032 series

#### Aluminum

41" W x 27.25" H

—

8 lbs

0.25 hr

No

# DRAWERS



## 5037-0

Axess Tray with 1 shelf / no drawers

### Aluminum

38" D x 45" W x 42" H

—

55 lbs

1 hr

No



## 5037-1

Axess Tray with 1 shelf / 1 drawer

### Aluminum

38" D x 45" W x 42" H

200 lbs

93 lbs

1.1 hrs

No



## 5037-2

Axess Tray with 1 shelf / 2 drawers

### Aluminum

38" D x 45" W x 42" H

200 lbs

131 lbs

1.2 hrs

No



## 5037-3

Axess Tray with 1 shelf / 3 drawers

### Aluminum

38" D x 45" W x 42" H

200 lbs

169 lbs

1.3 hrs

No



## 5037-A

Axess Tray drawer only,  
complete with slides

### Aluminum

38" D x 45" W

—

38 lbs

—

No

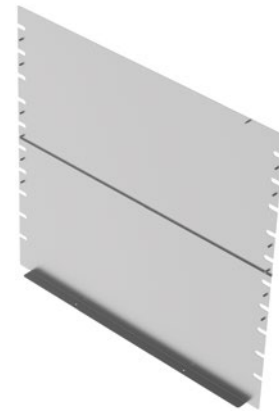

## 5037-F

Axess Tray full back panel for 5037 series

### Aluminum

41" W x 39.25" H

—

11 lbs

0.25 hr

No



## 5040

Cab box with locking lid, Mini-Van

### Aluminum

20" D x 6.5" W x 15.75" H

—

11 lbs

0.5 hr

No



## 5045

Cab box with locking lid, Mini-Van

### Aluminium

18.75" D x 12.25" W x 15.75" H

—

16 lbs

0.4 hr

Yes



## 5044

Raised base for 5045 cab box

### Aluminium

9" H

—

2 lbs

0.2 hr

Yes



5020 Tool drawer mounted with its complementary 5010 Partslider drawer and 5048 Top edge.



# DRAWERS



## 5060-5

5 Drawer cabinet and 1 door

### Aluminum

18" D x 24" W x 36" H

150 lbs

104 lbs

1 hr

No



## 5060-6

6 Drawer cabinet

### Aluminum

18" D x 24" W x 36" H

127 lbs

114 lbs

1 hr

Yes



## 5060-8

8 Drawer cabinet

### Aluminum

18" D x 24" W x 36" H

150 lbs

148 lbs

1 hr

No



## 5067-6

6 Drawer cabinet

### Aluminum

18" D x 18" W x 28" H

150 lbs

97 lbs

0.5 hr

No



## 5066-8

8 Drawer cabinet

### Aluminum

20.5" D x 24" W x 56" H

150 lbs

168 lbs

1 hr

No



## 5068-3

3 Drawer cabinet

### Aluminum

18" D x 15" W x 15" H

150 lbs

45 lbs

0.5 hr

Yes



**5069-2**  
2 Drawer cabinet

**Aluminum**

	14" D x 24" W x 12" H
	150 lbs
	34 lbs
	0.5 hr
	Yes



**X50-B**  
Compact 2-Drawer Unit

**Steel**

	12.5" D x 18.5" W x 10.5" H
	—
	19 lbs
	0.3 hr
	Yes



**X50-C**  
Compact 3-Drawer Unit

**Steel**

	12.5" D x 18.5" W x 10.5" H
	—
	20 lbs
	0.3 hr
	Yes



**X51-F**  
Compact 9-Drawer Unit

**Steel**

	12" D x 17" W x 12" H
	—
	26 lbs
	0.3 hr
	Yes



**5070**  
Partskeeper carry case with holder, universal

**Aluminum**

	14" D x 17" W x 5.5" H
	—
	9 lbs
	0.3 hr
	Yes



**5072**  
Partskeeper carry case with holder, floor mount

**Aluminum**

	14" D x 17" W x 8.75" H
	—
	7 lbs
	0.3 hr
	No

# DRAWERS



**5078**  
Partskeeper cabinet with 4 carry cases

Aluminum	
14" D x 17" W x 24" H	
—	
34 lbs	
0.3 hr	
Yes	

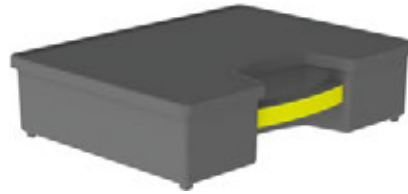

**5079**  
Partskeeper carry case

Plastic	
13" D x 16.5" W x 4" H	
—	
3 lbs	
—	
No	



**5082**  
Partskeeper cabinet with 8 carry cases

Aluminum	
14" D x 17" W x 43" H	
—	
54 lbs	
1 hr	
Yes	

DRAWERS



Two **5078** Partskeeper cabinet mounted side by side.



**5083**  
Partskeeper cabinet with 5 carry cases & 2 shelves

Aluminum	
14" D x 17" W x 43" H	
—	
41 lbs	
1 hr	
Yes	





## 5086

Partskeeper cabinet with 8 carry cases & 2 shelves

### Aluminum

14" D x 17" W x 62.5" H

—

65 lbs

1 hr

Yes

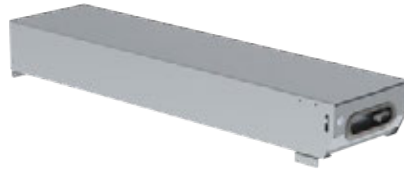

## 5010

Partslider drawer

### Aluminum

48" D x 12" W x 6" H

150 lbs

31 lbs

0.5 hr

Yes



## 5011

Partslider drawer

### Aluminum

36" D x 12" W x 6" H

150 lbs

24 lbs

0.5 hr

No



## 5014

Floor mount kit for 5010 / 5011 Partslider drawer

### Aluminum

—

—

2 lb

—

Yes



## 5048

Top edge, for 5010 Partslider

### Aluminum

48" D x 12" W x 4" H

—

7 lbs

0.2 hr

Yes



## 5049

Top edge, for 5020 Partslider

### Aluminium

48" D x 14" W x 4" H

—

5 lbs

0.2 hr

No

# DRAWERS



## 5050

Top edge, for 5025 Partslider

### Aluminium

48" D x 16" W x 4" H

—

5 lbs

0.2 hr

No



## 5051

Top edge, for 5011 Tool drawer

### Aluminium

36" D x 12" W x 4" H

—

5,6 lbs

0.2 hr

No



## 5052

Top edge, for 5021 Tool drawer

### Aluminium

36" D x 14" W x 4" H

—

4 lbs

0.2 hr

No



## 5053

Top edge, for 5026 Tool drawer

### Aluminium

36" D x 16" W x 4" H

—

4 lbs

0.2 hr

No



## 5057

Top edge, for 5060 Drawer cabinet

### Aluminium

18" D x 24" W x 4" H

—

4 lbs

0.2 hr

No



## 5020

Tool drawer

### Aluminium

48" D x 14" W x 16" H

320 lbs

70 lbs

1 hr

Yes



## 5021

Tool drawer

### Aluminum

36" D x 14" W x 16" H

320 lbs

46 lbs

1 hr

No



## 5025

Jumbo tool drawer

### Aluminum

48" D x 16" W x 19" H

320 lbs

67 lbs

1 hr

Yes



## 5026

Jumbo tool drawer

### Aluminum

36" D x 16" W x 19" H

320 lbs

72 lbs

1 hr

No



## 5028

Raised base for 5020 tool drawer

### Aluminum

6" D x 14" W x 6" H

-

7 lbs

0.5 hr

No



## 5029

Raised base for 5025 Jumbo tool drawer

### Aluminum

6" D x 16" W x 6" H

-

8 lbs

0.5 hr

No



## X02-A

Fleetline Tool Drawer

### Steel

45.5" D x 13.5" W x 22" H

-

88 lbs

1 hr

Yes

## ACCESSORIES

Choose the finishing details to tailor the upfit to your specific needs.

BINS .....	P. 64
BOTTLE HOLDERS .....	P. 61
HOOKS .....	P. 62
OTHERS .....	P. 63
PAPER HOLDERS .....	P. 62
SEAT COVERS .....	P. 65
WINDOW GRILLS .....	P. 65

The finishing details are just as important when you're setting up your commercial van as they are when you're on the job site. Customize your vehicle with our wide range of options to ensure that you can perform at peak efficiency.



### VERSATILE

Removable storage bins ensure organization on the jobsite or on the go.



### SECURE

Trade specific accessories with a place for all tools and supplies.



### PRODUCTIVE

Stay productive with the most used items well within reach.



## 6001

4 Tier refrigerant rack for large bottles

### Aluminum

14" D x 13" W x 62.5" H

34 lbs

0.7 hr

No



## 6002

5 Tier refrigerant rack for small bottles

### Aluminum

14" D x 10.5" W x 62.5" H

36 lbs

0.7 hr

No



## 6003

5 Tier refrigerant rack for large bottles

### Aluminum

14" D x 13" W x 62.5" H

36 lbs

0.7 hr

Yes



## 6006

3 Tier refrigerant rack for small bottles

### Aluminum

14" D x 10.5" W x 43" H

24 lbs

0.6 hr

No



## 6007

4 Tier refrigerant rack for small bottles

### Aluminum

14" D x 10.5" W x 43" H

22 lbs

0.6 hr

Yes



## 6008

3 Tier refrigerant rack for large bottles

### Aluminum

14" D x 13" W x 43" H

25 lbs

0.6 hr

No



## 6010

Two level adjustable bottle holder

### Aluminum

10.25" D x 9.5" W x 36" H

5 lbs

0.4 hr

No



## 6020

Horizontal refrigerant bottle holder

### Aluminum

12.5" D x 48" W x 13" H

17 lbs

0.5 hr

No



## 6030

Bottle rack with straps

### Aluminum

48" W

4 lbs

0.5 hr

No



## 6035

Bottle rack with straps

### Aluminum

60" W

5 lbs

0.5 hr

No



## 6040

Locking cabinet

### Aluminum

8.5" D x 12" W x 24" H

16 lbs

0.6 hr

No



## 6041

Locking cabinet

### Aluminum

15" D x 15.5" W x 33" H

26 lbs

0.7 hr

No

# ACCESSORIES



**6049**

Ventilation kit for cabinet

**Aluminum**

	0 lb
	No



**6086**

Small aluminum bottle holder, with a black nylon strap

**Aluminum**

	6" W x 12" H
	1 lb
	0.2 hr
	Yes



**6088**

Large aluminum bottle holder, with two black nylon straps

**Aluminum**

	8" W x 24" H
	2 lbs
	0.2 hr
	Yes

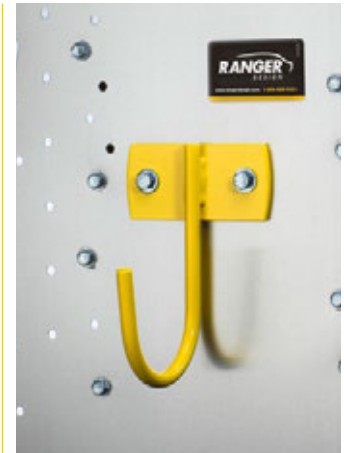

**6070** 6" Hook, 3" opening, painted



**6070**

6" Hook, 3" opening, painted

**Steel**

	3" D
	0.4 lb
	0.2 hr
	Yes



**6072**

8" Swivel Hook, 4" opening, painted

**Steel**

	4" D
	0.6 lb
	0.2 hr
	Yes



**6073**

Large aluminum movable hook, 6.5" opening

**Aluminum**

	6.5" D x 2.75" W x 4" H
	1 lb
	0.01 hr
	Yes



**Y30-C**

Coat Hook, 1" opening, chrome plated

**Steel**

	1" D
	0.1 lb
	0.2 hr
	Yes



**6052**

Vise Holder with an 8"x8" mounting plate

**Steel**

	37 lbs
	0.5 hr
	No



**6057**

Can Holder

**Aluminum**

	3" D x 8.5" W x 3" H
	1 lb
	0.2 hr
	No



**6061**

Paper Holder, extra deep, 2 slots

**Aluminum**

	3.75" D x 12.75" W x 12" H
	2 lbs
	0.2 hr
	No



**6063**

Paper Holder, extra deep, 5 slots

**Aluminum**

	3.75" D x 12.75" W x 24" H
	5 lbs
	0.2 hr
	Yes



## 6066

2 Pocket Holder, with 8 plastic bins

### Aluminum

4.5" D x 20" W x 21.75" H

7.5 lbs

0.2 hr

No



## 6067

Paper Holder, regular depth, 2 slots

### Aluminum

2.25" D x 12.75" W x 12" H

2 lbs

0.2 hr

No



## 6068

Hard Hat Holder, painted wire

### Steel

0.5 lb

0.2 hr

No



## 6069

Paper Holder, regular depth, 5 slots

### Aluminum

2.25" D x 12.75" W x 24" H

5 lbs

0.2 hr

No



## Y31-A

Paper Holder, extra deep, 3 slots

### Steel

3.75" D x 12.75" W x 16" H

9 lbs

0.2 hr

Yes



## 6095

Black Nylon Strap, plastic buckle

### Other

2" W x 28" H

0.18 lb

0.01 hr

No



## 6096

Black Nylon Strap, chrome plated buckle

### Other

1" W x 36" H

0.12 lb

0.01 hr

No



## 6097

Black Nylon Strap, chrome plated buckle

### Other

1" W x 48" H

0.13 lb

0.01 hr

No



## 6098

Black Nylon Strap, chrome plated buckle

### Other

1" W x 72" H

0.16 lb

0.01 hr

No



## 6075

Transport tube door, for 6" diameter tube with stainless steel hardware

### Aluminum

6" D

2 lbs

0.2 hr

No



## 6078

Cradle & strap kit for 6" dia. transport tube (one cradle and one strap)

### Aluminum

6" D

1 lb

0.1 hr

No

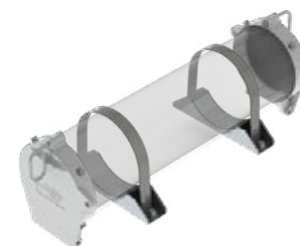

## 6079

Transport tube door kit complete (6" dia. PVC tube not included)

### Aluminum

6" D

6 lbs

0.8 hr

No

# ACCESSORIES



## 7124

Reel Holder with two 5/8" diameter rods

### Aluminum

7.25" D x 15" W x 24" H

9 lbs

0.5 hr

Yes



## 1130

Elevated strobe mount

### Aluminum

8" W

1 lb

0.1 hr

No

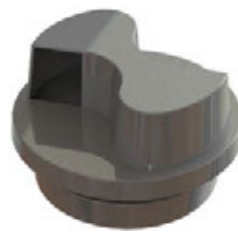

## 6050

Flettner vent, rotary design

### Plastic

8.88" D

1.5 lbs

1 hr

No



## 6054

Hitch Step, with hitch pin to fit a 2"x2" hitch

### Aluminum

6" D x 12" W

4 lbs

No



## 6082

Triangle kit with aluminum holder

### Other

14 lbs

0.2 hr

No



## 6090

Back up alarm, die cast housing, fully encapsulated circuitry

### Other

1 lb

1 hr

No



## 6091

Surface mount tie down ring, zinc plated

### Steel

4" D

0.4 lb

0.2 hr

No



## 6092

Dome Light, chrome finish housing

### Other

8.5" D

1 lb

1 hr

No



## 6093

Grab handle

### Plastic

9.5" D

0.1 lb

0.5 hr

No

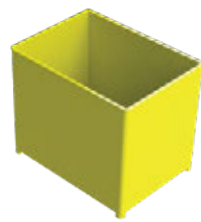

## 6205

Bin cup

### Plastic

4.5" D x 3.25" W x 3.75" H

0.12 lb

No



## 6211

Small Bin, Graphite

### Plastic

6.5" D x 4" W x 3" H

0.24 lb

Yes



## 6212

Divider for 6211 small bin

### Aluminum

0 lb

No





**6221**  
Medium Bin, Graphite

Plastic	
10" D x 6" W x 4.5" H	
0.56 lb	
Yes	



**6222**  
Divider for 6221 medium bin

Aluminum	
0 lb	
No	



**6231**  
Large Bin, Graphite

Plastic	
14" D x 8" W x 5.5" H	
1.3 lbs	
Yes	



**6232**  
Divider for 6231 large bin

Aluminum	
0 lb	
No	

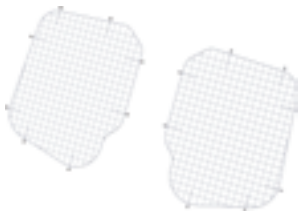

**6107**  
Set of 2 rear window grills

Steel	
Standard Roof / High Roof	
8 lbs	
0.2 hr	
No	



**6117**  
Window grill, passenger side sliding door

Steel	
Standard Roof / High Roof	
8 lbs	
0.2 hr	
Non	



**3024**  
Partition window with frame for 3020, 3025, 3068

Aluminum	
Universal	
5 lbs	
0.5 hr	
No	

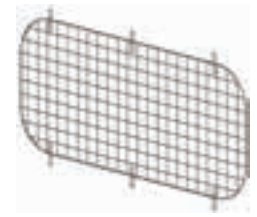

**3044**  
Grill for partition window for 3020, 3025, 3068

Steel	
Universal	
2 lbs	
0.5 hr	
No	

ACCESSORIES

## INTRODUCING THE NEW RANGER DESIGN

# SEAT COVERS

**6257**  
Seat covers

4 lbs	
0.5 hr	
Yes	



### Our key advantages are:

- Durable material and easy maintenance
- Durable material and easy maintenance
- Urethane coating to make the fabric water and stain resistant
- Machine wash and dryer safe
- No interference with factory seat functions (heating, cooling or air bag)
- Minimal seams
- Tight custom fit for each vehicle, guaranteed to stay in place
- Puncture resistant to prevent seat damage
- Durable Cordura® fabric with a 1 year warranty

## LADDER RACKS

Ergonomic Ladder Racks make loading and unloading easier.

ACCESSORY .....	P. 67
CARGO RACK .....	P. 67
COMBINATION LADDER RACK .....	P. 68
DOUBLE CLAMP LADDER RACK .....	P. 68
MAX RACK .....	P. 69
STANDARD LADDER RACK .....	P. 67

Ranger ladder racks make loading and unloading ladders an easy operation. Ranger Design offers drop-down ladder racks for high roof vans, extra tough racks capable of carrying 28' ladders on compact vans, interior ladder carriers and many other options for different applications.



### TOUGH

Military grade aluminum extrusion, high density plastic and stainless steel components ensure no corrosion over the lifetime of the rack.



### QUIET

Aerodynamic design with minimal wind noise.



### SAFE

No metal contact to ladder, leading to longer life of ladders with less chance of fiberglass splinters.





Ladder rack accessory

**Aluminum**

<b>1127</b>	Universal	Universal	23" W	—	18 lbs	—	0.5 hr



Passenger Side Retrofit kit

**Aluminum**

<b>15-1810</b>	Universal	Universal	—	—	57 lbs	—	1 hr



Access Pro, Inside Ladder Carrier

**Aluminum**

<b>1050-FS</b>	Universal	Universal	96" W	—	9 lbs	—	1 hr



Driver Side Retrofit kit

**Aluminum**

<b>15-1815</b>	Universal	Universal	—	—	57 lbs	—	1 hr



Third bar crossbow kit for Max Rack

**Aluminum**

<b>15-1805</b>	Universal	Universal	72" W	200 lbs	10 lbs	—	0.5 hr



Cargo rack

**Aluminum**

<b>1505-DH</b>	Universal	High Roof	68" L	480 lb	20 lb	—	0,8 h

# LADDER RACKS



Cargo rack

Aluminum



**1505-DH3** Universal High 68" W 720 lbs 30 lbs 1.2 hrs



Single clamp ladder rack

Aluminum

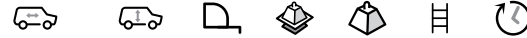

**1520-DH** Universal High 68" W 400 lbs 30 lbs 32 ft 1.2 hrs



Standard ladder rack

Aluminum



**1510-DH** Universal High 68" W 400 lbs 21 lbs 0.9 hr



Combination ladder rack

Aluminum

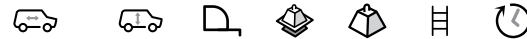

**1525-DH** Universal High 68" W 400 lbs 48 lbs 32 ft 1.7 hrs



Standard ladder rack

Aluminum



**1510-DH3** Universal High 68" W 600 lbs 30 lbs 1.3 hrs



Combination ladder rack

Aluminum



**1525-DH3** Universal High 68" W 600 lbs 57 lbs 32 ft 2.1 hrs

# LADDER RACKS



Double clamp ladder rack

**Aluminum**

<b>1530-DH</b>	Universal	High	68" W	400 lbs	49 lbs	32 ft	1.7 hrs



Max Rack, Double side ladder rack

**Aluminum**

<b>1830-DH</b>	Universal	High	72" W	139 lbs	32 lbs	32 ft	3 hrs



Double clamp ladder rack

**Aluminum**

<b>1530-DH3</b>	Universal	High	68" W	600 lbs	58 lbs	32 ft	2.1 hrs



Max Rack, Single side ladder rack

**Aluminum**

<b>1820-DH</b>	Universal	High	72" W	82 lbs	32 lbs	32 ft	2 hrs



Max Rack ladder rack

LADDER RACKS

**LEGEND**

- Wheelbase
- Roof Height
- Dimensions
- Weight Capacity
- Install Time
- Weight



# MAX RACK

DESIGNED FOR HIGH ROOF VANS

## SAFE & EASY TO USE

### 50" OF TRAVEL

The Max Rack drops lower in one movement than any other rack in the industry.

- Max Rack
- Competitor's rack

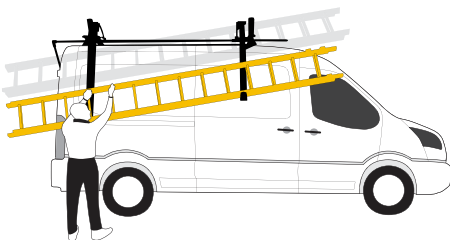

- › Two pressurized gas shocks support the weight of the ladder, assist in lifting and lowering the ladder and also hold it in the closed position.
- › Max Rack is adjustable to fit most ladders.

### LOW PROFILE

There is less chances of the Max Rack hitting low hanging objects.



- › Ladders only touch composite materials, reducing ladder wear.
- › Comes down in one single motion.

### EXTREME WEATHER PROOF

The Max Rack was put through extreme weather testing.



### CYCLE TESTING

The Max Rack completed over 4300 cycles, which represents approximately 15 years of normal use.

# MAX RACK IS FAST AND EASY TO OPERATE

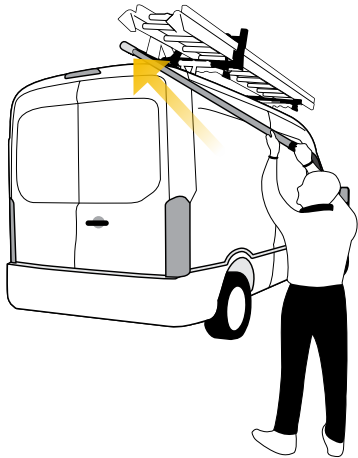

1

## STEP ONE

With both hands, insert the control arm into the Max Rack.

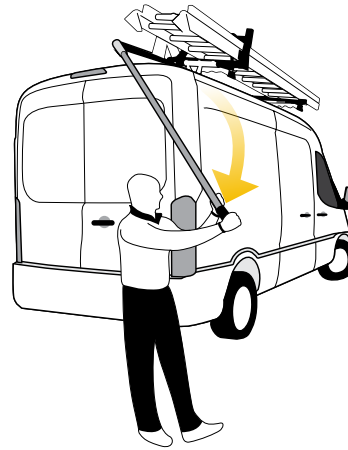

2

## STEP TWO

Pull the control arm down towards you.

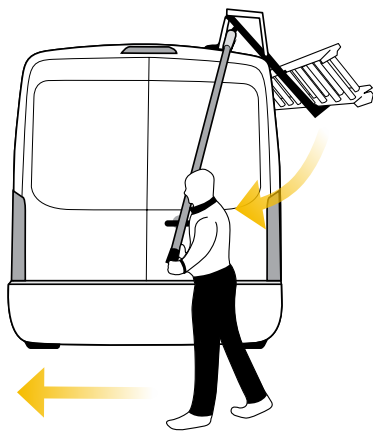

3

## STEP THREE

Turn around. Push the control arm forward.

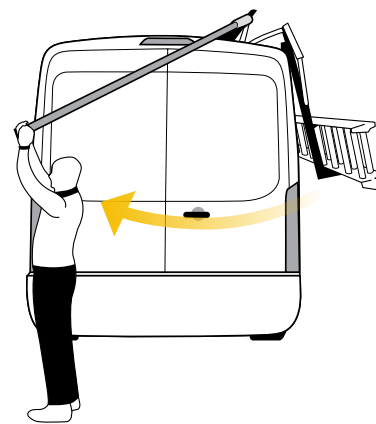

4

## STEP FOUR

Continue to push the control arm until the Max Rack has finished its descent.

## RACK CAPACITY



STEP LADDERS  
**8' AND 10'**

Fits all Max Racks



The Max Rack can carry extension ladders up to 32' for the standard and high roof vans, with a third bar option #15-1805.

The weight capacity per single Max Rack is 100lbs.

# Over 350 Distributors Across the Continent

## Regular Order

## Quickship Order

**Buy**

Contact one of our 350 distributors  
[rangerdesign.com/find-dealer](http://rangerdesign.com/find-dealer).

Ranger Quickship service is available  
through your local distributor.

**Lead  
Time**

Orders ship from our factory within  
5 business days.

Orders placed with Ranger before 1PM EST will  
ship from our factory in the next business day.



Throughout the catalog products and packages with this symbol  
can be ordered through our Quickship service.



# Turn-Key Fleet Services



## Ship Through or Local Installation Across North America for all Types of Cargo Vans

We are pleased to offer efficient, personalized service and to answer all questions regarding:

### 1. Analysis

- › Cargo Needs Analysis
- › Custom 3D CAD Layouts
- › Hands-on Equipment Demo

### 2. Testing

- › Test Fitting
- › Pilot Build and Review
- › Optimize Package Based on Technician Feedback

### 3. Delivery

- › Delivery, Production and Installation Planning and Scheduling
- › Vehicle Status Tracking

### 4. Service

- › Dedicated Fleet Account Management Team
- › 300 Ranger Distributor Service Support Network
- › Live Customer Service

# INDEX

1050-FS.....	67	5028.....	59	6030.....	61	7209.....	47
1127.....	67	5029.....	59	6035.....	61	7210.....	47
1130.....	64	5032-0.....	51	6040.....	61	7211.....	47
15-1805.....	67	5032-1.....	51	6041.....	61	7247.....	48
15-1810.....	67	5032-2.....	51	6049.....	62	7248.....	48
15-1815.....	67	5032-3.....	51	6050.....	64	7720.....	49
1505-DH.....	67	5032-A.....	51	6052.....	62	7722.....	49
1505-DH3.....	68	5032-F.....	51	6054.....	64	7723.....	49
1510-DH.....	68	5037-0.....	52	6057.....	62	7724.....	49
1510-DH3.....	68	5037-1.....	52	6061.....	62	7725.....	49
1520-DH.....	68	5037-2.....	52	6063.....	62	7727.....	49
1525-DH.....	68	5037-3.....	52	6066.....	63	7728.....	49
1525-DH3.....	68	5037-A.....	52	6067.....	63	7729.....	49
1530-DH.....	69	5037-F.....	52	6068.....	63	7730.....	49
1530-DH3.....	69	5040.....	53	6069.....	63	7731.....	49
1820-DH.....	69	5044.....	53	6070.....	62	7732.....	49
1830-DH.....	69	5045.....	53	6072.....	62	7733.....	49
3010-DH.....	15	5048.....	57	6073.....	62	7734.....	49
3010-DL.....	15	5049.....	57	6075.....	63	7735.....	49
3015-DH.....	15	5050.....	58	6078.....	63	7737.....	49
3020-DH.....	15	5051.....	58	6079.....	63	7738.....	49
3020-DL.....	15	5052.....	58	6082.....	64	7739.....	49
3024.....	65	5053.....	58	6086.....	62	7740.....	49
3025-DH.....	16	5057.....	58	6088.....	62	7848.....	43
3044.....	65	5060-5.....	54	6090.....	64	7936.....	38
3060-DH.....	16	5060-6.....	54	6091.....	64	7948.....	38
3060-DL.....	16	5060-8.....	54	6092.....	64	7960.....	38
3064-DH.....	16	5066-8.....	54	6093.....	64	84-1830.....	44
3068-DH.....	16	5067-6.....	54	6095.....	63	84-1836.....	44
3068-DL.....	16	5068-3.....	54	6096.....	63	84-1848.....	44
4136-4.....	39	5069-2.....	55	6097.....	63	84-1858.....	44
4136-5.....	39	5070.....	55	6098.....	63	84-1872.....	44
4148-4.....	39	5072.....	55	6107.....	65	84-2130.....	44
4148-5.....	39	5078.....	56	6117.....	65	84-2136.....	44
4160-5.....	39	5079.....	56	6205.....	64	84-2148.....	44
4172-4.....	39	5082.....	56	6211.....	64	84-2158.....	44
4172-5.....	40	5083.....	56	6212.....	64	84-2172.....	44
4184-4.....	39	5086.....	57	6221.....	65	84-3033.....	44
4184-5.....	40	5748.....	38	6222.....	65	84-3039.....	44
4196-4.....	39	5760.....	38	6231.....	65	84-3051.....	44
4196-5.....	40	6001.....	61	6232.....	65	84-3061.....	44
5010.....	57	6002.....	61	6257.....	65	84-3075.....	44
5011.....	57	6003.....	61	6540-DR.....	11	84-7063.....	45
5014.....	57	6006.....	61	7108.....	46	8436-2.....	44
5020.....	58	6007.....	61	7111.....	47	8448-2.....	44
5021.....	59	6008.....	61	7124.....	64	8448-3.....	44
5025.....	59	6010.....	61	7207.....	47	8458-2.....	44
5026.....	59	6020.....	61	7208.....	47	8458-3.....	44

8472-2 . . . . .	44	C30-DL . . . . .	14	H38-T . . . . .	42	X51-F . . . . .	55
8472-3 . . . . .	44	F38-T . . . . .	43	H38-X . . . . .	45	Y10-C . . . . .	49
8748 . . . . .	39	F38-X . . . . .	46	H42-T . . . . .	42	Y10-D . . . . .	49
8760 . . . . .	39	F42-T . . . . .	43	H42-X . . . . .	45	Y10-F . . . . .	49
8848-5 . . . . .	40	F42-X . . . . .	46	H56-T . . . . .	42	Y10-H . . . . .	49
8848-6 . . . . .	40	F56-T . . . . .	43	H56-X . . . . .	45	Y10-J . . . . .	49
8860-5 . . . . .	40	F56-X . . . . .	46	H70-T . . . . .	42	Y10-M . . . . .	49
8860-6 . . . . .	40	F70-T . . . . .	43	H70-X . . . . .	45	Y11-C . . . . .	49
8872-5 . . . . .	40	F70-X . . . . .	46	H87-T . . . . .	42	Y11-D . . . . .	49
8872-6 . . . . .	42	F87-T . . . . .	43	H87-X . . . . .	45	Y11-E . . . . .	49
8884-5 . . . . .	40	F87-X . . . . .	46	J48-X . . . . .	48	Y11-F . . . . .	49
8884-6 . . . . .	42	G210 . . . . .	20	K48-X . . . . .	48	Y11-J . . . . .	49
8896-5 . . . . .	40	G211 . . . . .	23	L38-T . . . . .	42	Y11-M . . . . .	49
8896-6 . . . . .	42	G212 . . . . .	25	L38-X . . . . .	45	Y12-C . . . . .	49
8936-7 . . . . .	38	G215 . . . . .	35	L42-T . . . . .	42	Y12-D . . . . .	49
8936-8 . . . . .	38	G216 . . . . .	27	L42-X . . . . .	45	Y12-F . . . . .	49
8948-7 . . . . .	38	G217 . . . . .	29	L56-T . . . . .	42	Y12-J . . . . .	49
8948-8 . . . . .	38	G219 . . . . .	33	L56-X . . . . .	45	Y12-M . . . . .	49
8960-7 . . . . .	38	G710 . . . . .	20	L70-T . . . . .	42	Y30-C . . . . .	62
8960-8 . . . . .	38	G711 . . . . .	23	L70-X . . . . .	45	Y31-A . . . . .	63
C20-DH . . . . .	14	G712 . . . . .	25	L87-T . . . . .	43	Z10-G2 . . . . .	21
C20-DL . . . . .	14	G715 . . . . .	35	L87-X . . . . .	46	Z10-G7 . . . . .	21
C24-DH . . . . .	14	G716 . . . . .	27	X02-A . . . . .	59	Z16-G2 . . . . .	31
C24-DL . . . . .	14	G717 . . . . .	29	X50-B . . . . .	55	Z16-G7 . . . . .	31
C30-DH . . . . .	14	G719 . . . . .	33	X50-C . . . . .	55		



**NEED HELP WITH YOUR ORDER**

Contact us at [cs@rangerdesign.com](mailto:cs@rangerdesign.com)  
or call **1-800-565-5321**

**Ask us for our other Mercedes-Benz  
product related catalogs.**

# Maximize Cargo Capacity & Vehicle Performance With Contractor Grade, Organized Storage Systems

When you want the perfect upfit solution for your work vehicle, turn to Ranger Design. Tested for toughness, Ranger's shelving and upfits will take whatever abuse you can dish out. Their unsurpassed craftsmanship, combined with ideal fit and finish, provide a quiet ride with no rattles.



## CUSTOMER SERVICE

cs@rangerdesign.com  
1-800-565-5321  
rangerdesign.com



## THE PERFECT FIT FOR YOUR TOUGHEST JOBS