

MERCEDES-BENZ
METRIS



UPFIT
GUIDE

RANGERTM
DESIGN

Helping Mobile Technicians Work More Effectively by Providing Organized Storage Solutions

At Ranger Design, we believe more is possible.

We believe work vehicles and the technicians that drive them can become more organized, more efficient, more productive and more profitable. At Ranger Design we're committed to bringing you the products and services that make that possible.

More means helping you choose the right work van for your

application, as well as giving you engineering support and expert advice to help design the most efficient work space in your new vehicle.

More also means getting that new van outfitted and on the road faster, so you can start using it for the reason you bought it.

We're committed to bringing you more, because we believe more is possible.



MORE IS POSSIBLE



TABLE OF CONTENTS

CHOOSE A PRODUCT LINE	P. 4
PLAN YOUR VAN OUTFIT	P. 6
PARTITIONS	P. 8
PACKAGES	P. 10
SHELVING	P. 34
DRAWERS	P. 40
ACCESSORIES	P. 50
LADDER RACKS	P. 62
HOW TO BUY	P. 64
INDEX	P. 66

Choose A Product Line To Match Your Needs

Ranger Fleetline and Proline product groups ensure that fleets of any size have the best equipment to fit their budget, trade or fuel saving targets.



Ranger Fleetline shown

Ranger Proline shown

	MATERIAL	BENEFITS	PRODUCTS	WARRANTY
WHY BUY RANGER FLEETLINE? You want better quality and price than other steel products on the market.	Steel	Tough Low cost Quiet	Shelving, Partitions, Drawers, Accessories	3 years*
WHY BUY RANGER PROLINE? You want the toughest, quietest product on the market. You need to optimize payload without sacrificing quality.	Aluminum	Toughest Lightweight Quiet	Shelving, Partitions, Drawers, Accessories, Ladder Racks	10 years*

*Ranger Design Inc. van equipment is warranted to be free from defects in material and workmanship under normal use and service for the period indicated, from the date of the original retail purchase, when installed per Ranger Design instructions in the original vehicle. Please contact Customer Service for full warranty details. Email: cs@rangerdesign.com

Throughout the catalog **FLEETLINE** products are depicted with yellow and **PROLINE** products with black.

1-800-565-5321
7 A.M. – 8 P.M. EST

World Class Customer Service



Real people, ready to answer in 2 rings or less*

We are pleased to offer efficient, personalized service and to answer all questions regarding:

- › Pricing/Quoting
- › Product install
- › Order status
- › Consultation
- › Shipment status
- › New product availability
- › Product specifications
- › Warranty claims
- › Returns/Restocking
- › Vehicle specifications

*Call customer service and the phone will be answered in 2 rings or less. Yes, a real, live person working in one of our offices in North America is available to answer your questions. No automated attendant. No complicated phone tree and offshore service. Call us to experience the difference.

PLAN YOUR VAN OUTFIT

PARTITION DEPTH

This indicates the space taken up by our partition for this vehicle. Please note that this measurement is determined by the partition that encroaches the most. Some partitions may take up less space. Take note that this measurement may not necessarily be on the floor.

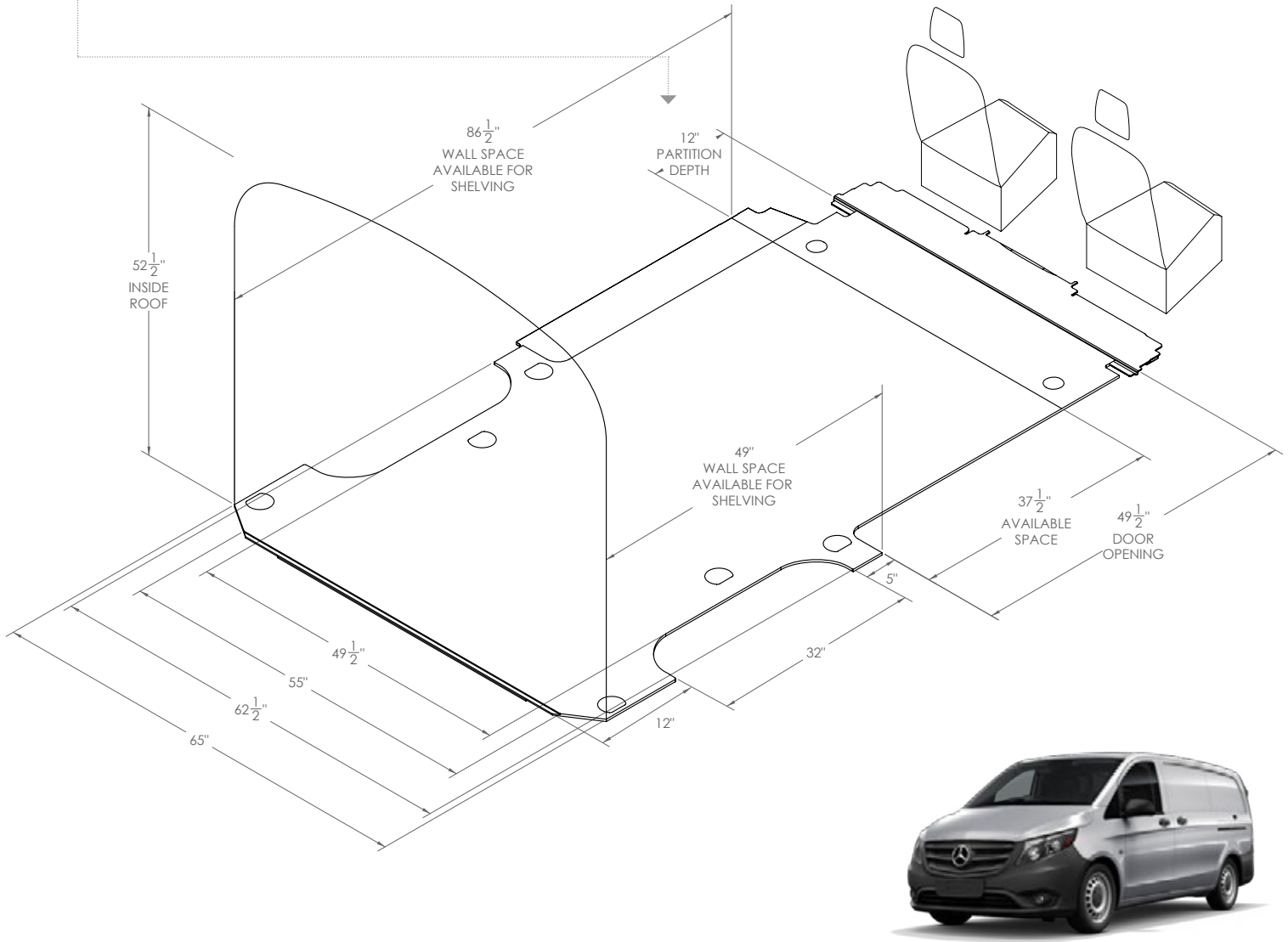

SAFETY PARTITIONS

Impact tested safety partitions protect the most important asset: you

Ranger safety partitions provide a solid and secure barrier between the occupants of the van and the cargo.

Built from heavy gauge steel, aluminum and thermoformed ABS and polycarbonate, they are designed for maximum impact resistance and uphold a standard of safety set only by Ranger products.

Ranger partitions also provide a more comfortable environment for the driver by giving more seat travel and by not rattling as the vehicle drives down the road.

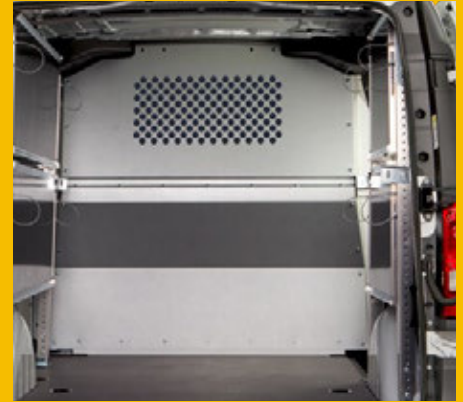

SAFE

Designed for maximum impact resistance. Proven by impact testing.



EFFICIENT

1. Contoured to maintain seat travel and ensure driver comfort. 2. Contoured to capitalize on cargo area floor space.

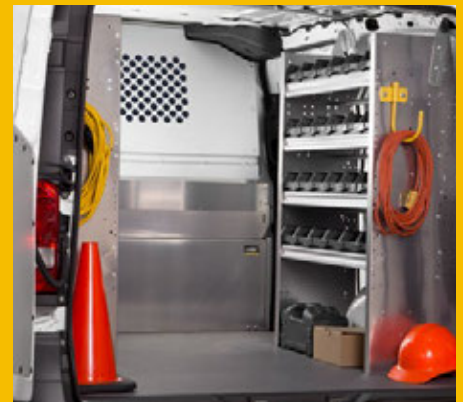

QUIET

Thickness of material cancels vibrations.

MAX VIEW SAFETY PARTITION



WINNER OF



2016
INNOVATION
AWARD

Max View Safety Partitions are built from thermoformed ABS and polycarbonate and are engineered to resist maximum impact. With a snug fit and rattle free construction they give you:

- > Maximized seat travel
- > 180 degree rear visibility
- > Improved climate control

3320-MM

Max View Contoured Safety Partition

Composite

- 48 lbs
- 1.2 hr
- Yes

PARTITIONS



C13-MM

Wire Mesh Partition

Steel

- 37 lbs
- 1.2 hr
- Yes

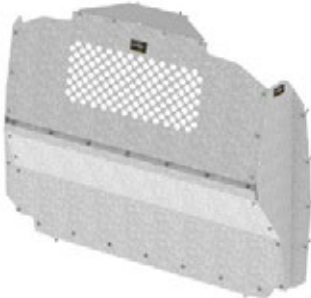

C10-MM

Contoured Safety Partition with Perforated Window

Steel

- 62 lbs
- 1 hr
- Yes



3320-MM

Max View Safety Partition

Composite

- 48 lbs
- 1.2 hrs
- Yes





TRADE PACKAGES

Pre-engineered packages for a broad range of trades.



CHOICE

A range of Fleetline and Proline packages are available for each vehicle.

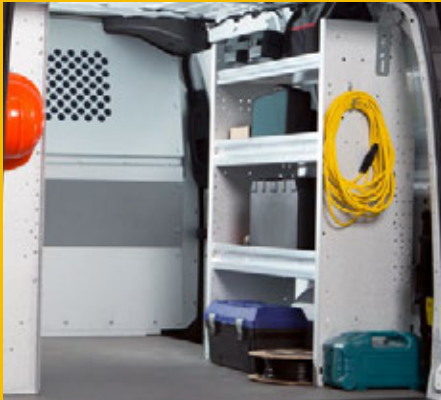

TRADE SPECIFIC

Packages are created with the specific trades in mind. Optimized for maximum productivity.



PERFECT FIT

Engineered to optimize space. Layout designed to ensure that all tools are well within reach.

TRADE PACKAGES

CONTRACTOR	P. 12
DELIVERY	P. 30
ELECTRICAL	P. 16
HVAC	P. 20
SERVICE	P. 24

Get more out of your work van: Ranger Design packages are designed specifically with your trade in mind. Our aim is to ensure that your most frequently used tools and equipment are well within reach.

Do you see a way that we can improve our packages? We appreciate your feedback! Contact our customer service team at **1-800-565-5321**.





Z10-M1

Contractor Package

TOUGH

Extrusion builds durability into shelf.

QUIET

The combination of the extrusion, shelf tray, and end-panels create durable, vibration-free shelves.

EFFICIENT

Ergonomic design reduces injuries and increases productivity.



*Preproduction model shown,
do not use as an installation guide.

Z10-M0

Steel

Base Contractor Package

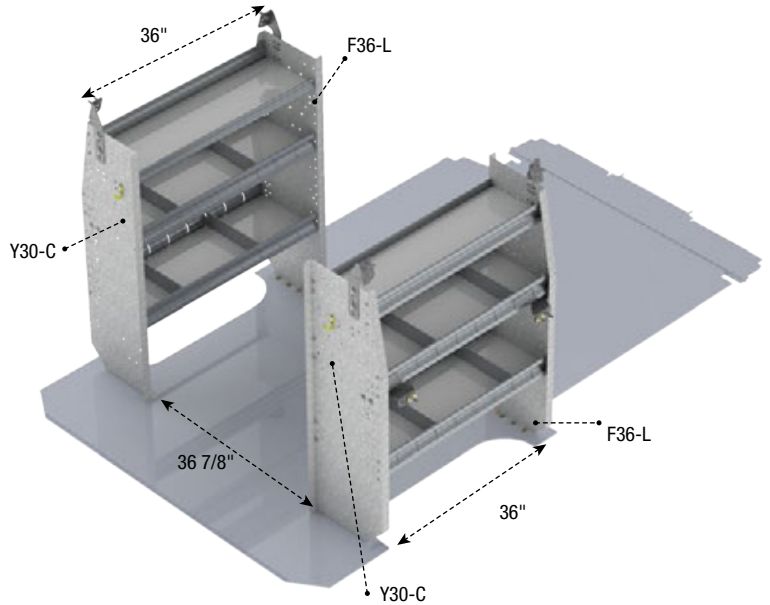

Z10-M0

Qty	Part #	Description
2	F36-L	Shelf unit, 36" L.
2	Y30-C	Small hook

The **Base** package is designed to fit in a Metris with dual sliding doors.

92 lbs

2.4 hrs

Yes

ADD YOUR
ACCESSORIES
P.50



PICK YOUR
PARTITION
P.8



CHOOSE YOUR
LADDER RACK
P.62



Z10-M1

Steel

Deluxe Contractor Package

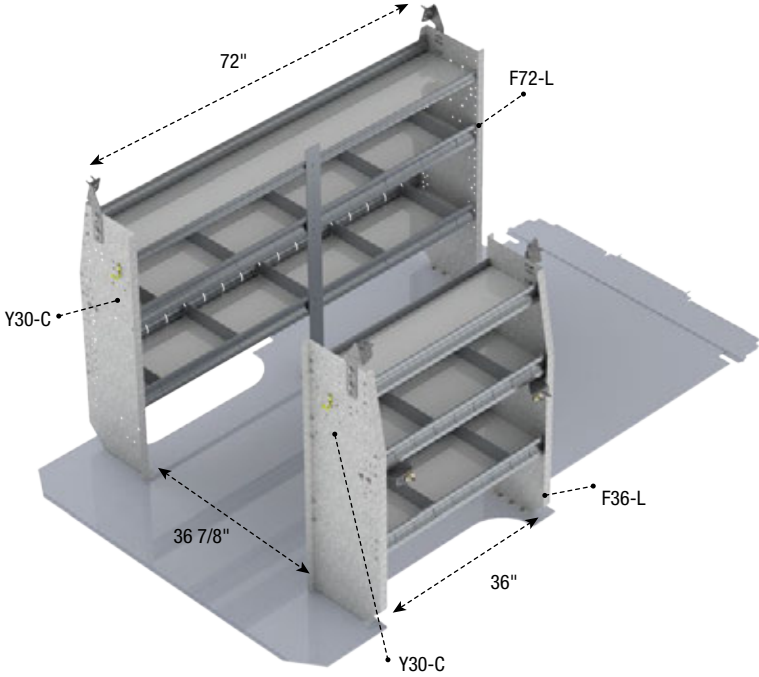

Z10-M1

Qty	Part #	Description
1	F36-L	Shelf unit, 36" L.
1	F72-L	Shelf unit, 72" L.
2	Y30-C	Small hook

The *Deluxe* package is designed to fit in a Metris with a single sliding door.

113 lbs
 2.4 hrs
 Yes

GET MORE OUT OF YOUR WORK VAN

Ranger Design packages are designed specifically with your trade in mind. Our aim is to ensure that your most frequently used tools and equipment are well within reach. Do you see a way that we can improve our packages? We appreciate your feedback! **Contact our customer service team at 1-800-565-5321.**





M111

Electrical Package

TOUGH

Extrusion builds durability into shelf.

QUIET

The combination of the extrusion, shelf tray, and end-panels create durable, vibration-free shelves.

EFFICIENT

Ergonomic design reduces injuries and increases productivity.



*Preproduction model shown,
do not use as an installation guide.

M011

Aluminum

Base Electrical Package

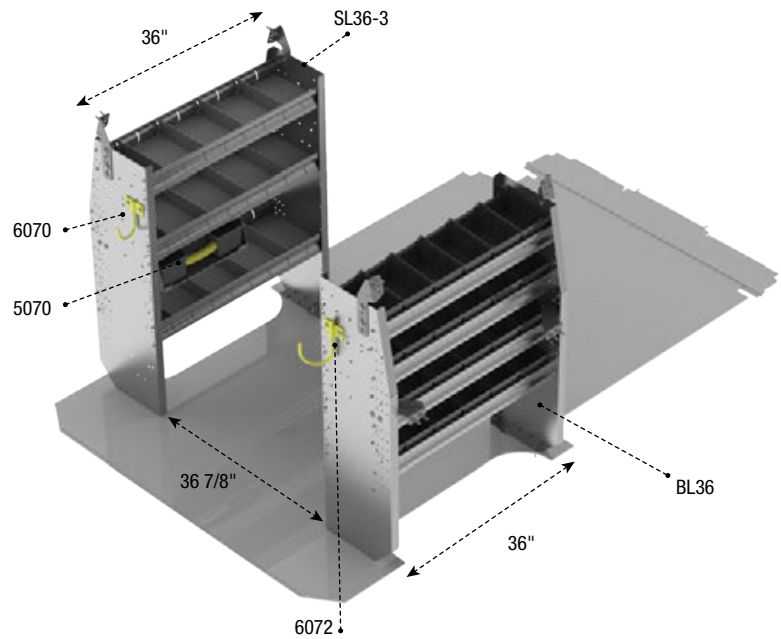

M011

Qty	Part #	Description
1	5070	Partskeeper case with shelf mount holder
1	6070	Large hook, fixed
1	6072	Large hook, swivel
1	BL36	Bin unit, 36" L.
1	SL36-3	Shelf unit, 36" L.

The **Base** package is designed to fit in a Metris with dual sliding doors.

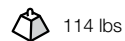

114 lbs



2.7 hrs



Yes

ADD YOUR
ACCESSORIES
P.50



PICK YOUR
PARTITION
P.8



CHOOSE YOUR
LADDER RACK
P.62



M111

Aluminum

Deluxe Electrical Package

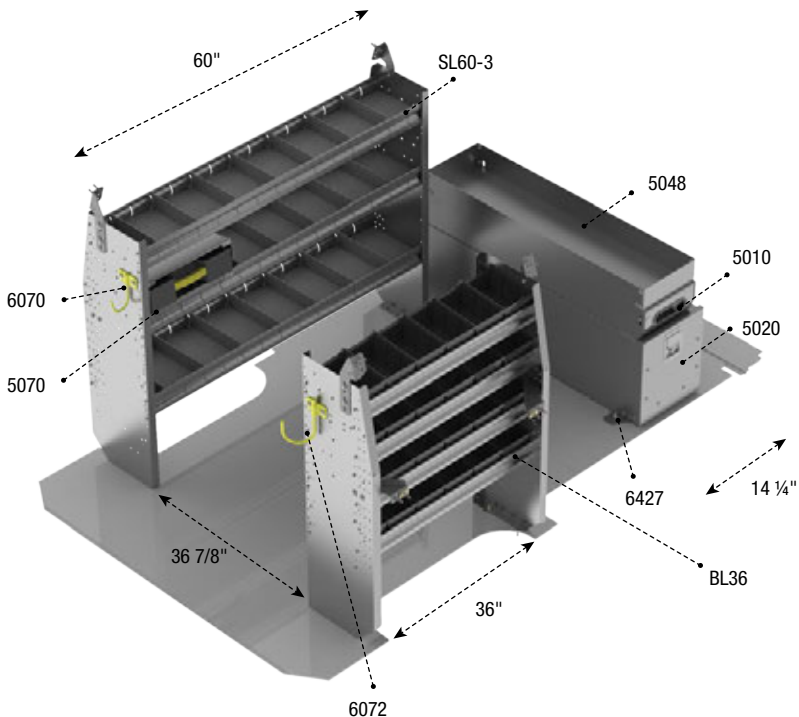

M111

Qty	Part #	Description
1	5010	Partslider drawer
1	5020	Tool drawer
1	5048	Top edge for partslider drawer
1	5070	Partskeeper case with shelf mount holder
1	6070	Large hook, fixed
1	6072	Large hook, swivel
1	6427	5020 Tool drawer install kit
1	BL36	Bin unit, 36" L.
1	SL60-3	Shelf unit, 60" L.

The *Deluxe* package is designed to fit in a Metris with a single sliding door.

216 lbs

4.9 hrs

Yes

RANGER DESIGN BINS

Ranger Design bins ensure complete organization on the jobsite or on the go.

P.51





M112

HVAC Package

TOUGH

Extrusion builds durability into shelf.

QUIET

The combination of the extrusion, shelf tray, and end-panels create durable, vibration-free shelves.

EFFICIENT

Ergonomic design reduces injuries and increases productivity.



*Preproduction model shown,
do not use as an installation guide.

M012

Aluminum

Base HVAC Package

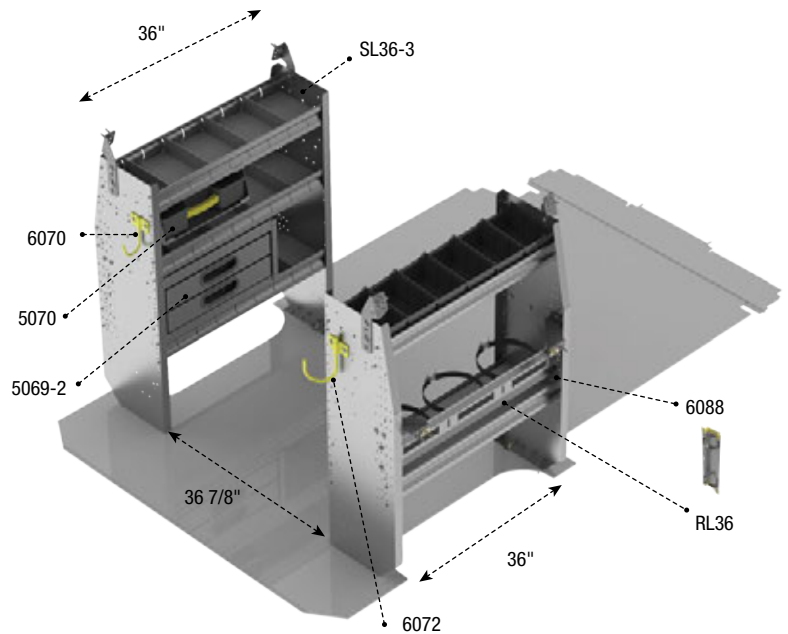

M012

Qty	Part #	Description
1	5069-2	Drawer cabinet
1	5070	Partskeeper case with shelf mount holder
1	6070	Large hook, fixed
1	6072	Large hook, swivel
1	6088	Large bottle/tank holder
1	RL36	Refrigerant unit, 36" L.
1	SL36-3	Shelf unit, 36" L.

The **Base** package is designed to fit in a Metris with dual sliding doors.



126 lbs



3.4 hrs



Yes

ADD YOUR
ACCESSORIES
P.50



PICK YOUR
PARTITION
P.8



CHOOSE YOUR
LADDER RACK
P.62



M112

Aluminum

Deluxe HVAC Package

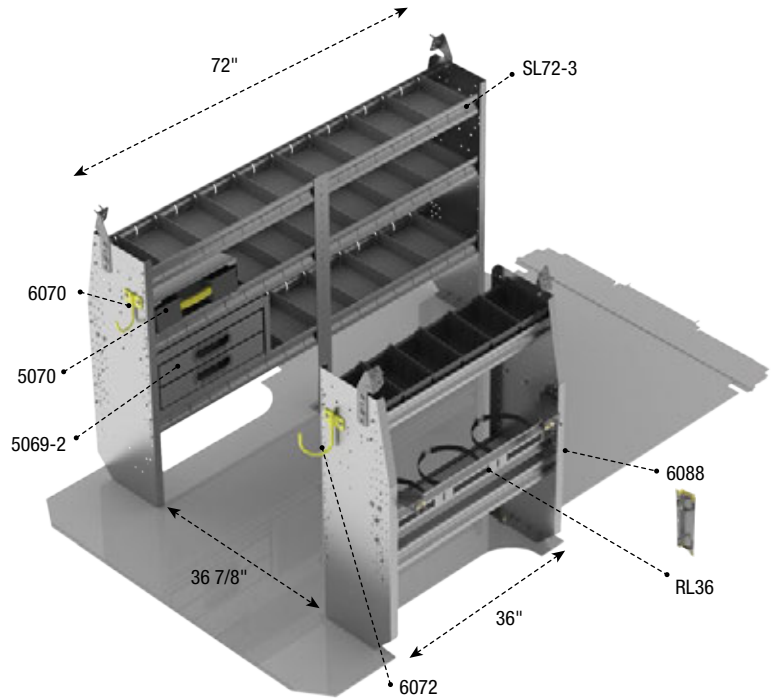

M112

Qty	Part #	Description
1	5069-2	Drawer cabinet
1	5070	Partskeeper case with shelf mount holder
1	6070	Large hook, fixed
1	6072	Large hook, swivel
1	6088	Large bottle/tank holder
1	RL36	Refrigerant unit, 36" L.
1	SL72-3	Shelf unit, 72" L.

The **Deluxe** package is designed to fit in a Metris with a single sliding door.

155 lbs

3.4 hrs

Yes

RANGER DESIGN DRAWER CABINETS

The Ranger Design drawer cabinets feature:

- › Ball bearing drawer slides
- › Concealed double latch per drawer with braided stainless steel cable pull
- › 1/8" rubber mat in each drawer and four dividers per drawer.
- › Locking bar allows padlocking of all compartments simultaneously.
- › Each drawer has a 150 lbs weight capacity.

P.46





Z16-M1

Service Package

TOUGH

Extrusion builds durability into shelf.

QUIET

The combination of the extrusion, shelf tray, and end-panels create durable, vibration-free shelves.

EFFICIENT

Ergonomic design reduces injuries and increases productivity.



*Preproduction model shown,
do not use as an installation guide.

Z16-M0

Steel

Base Service Package

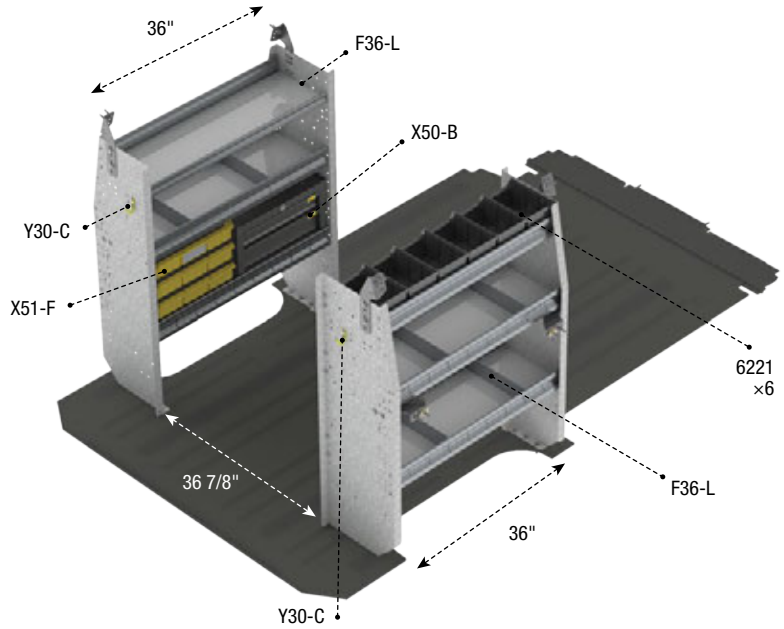

Z16-M0

Qty	Part #	Description
2	F36-L	Shelf unit, 36" L.
1	X50-B	2 Drawer unit, compact, Fleetline
1	X51-F	9 Drawer unit, Fleetline
2	Y30-C	Small hook
6	6221	Stacking bin, graphite, medium

The Base package is designed to fit in a Metris with dual sliding doors.



141 lbs



3 hrs



Yes

RANGER DESIGN 9 DRAWER CABINET

X51-F The new steel 9-drawer cabinet will fit any package or upfit

- > Great for organizing small parts
- > Affordably priced
- > Easily installs side by side or stacked vertically

P.49



Z16-M1

Steel

Deluxe Service Package

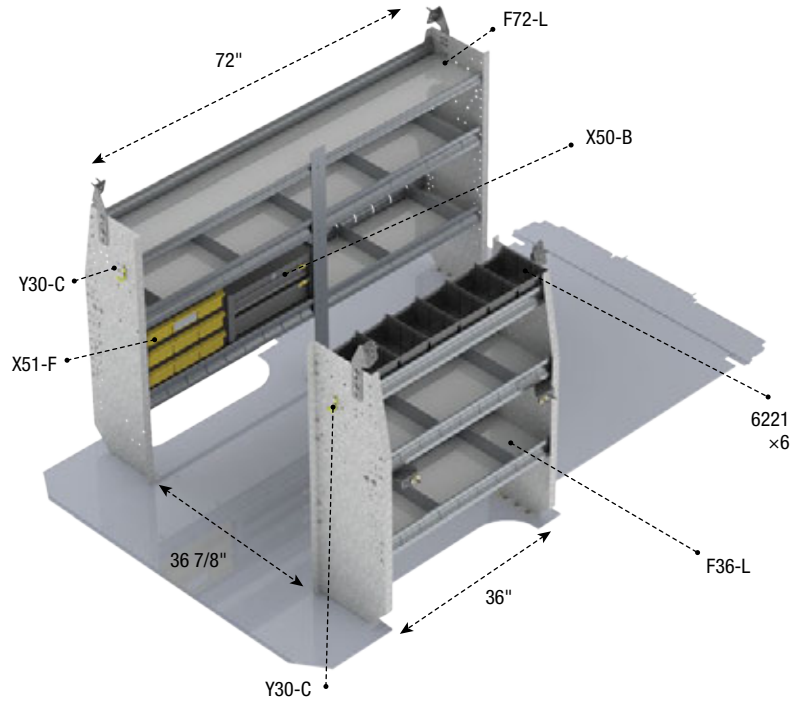

Z16-M1

Qty	Part #	Description
1	F36-L	Shelf unit, 36" L.
1	F72-L	Shelf unit, 72" L.
1	X50-B	2 Drawer unit, compact, Fleetline
1	X51-F	9 Drawer unit, Fleetline
2	Y30-C	Small hook
6	6221	Stacking bin, graphite, medium

The *Deluxe* package is designed to fit in a Metris with a single sliding door.

162 lbs

3 hrs

Yes

ADD YOUR
ACCESSORIES
P.50



PICK YOUR
PARTITION
P.8



CHOOSE YOUR
LADDER RACK
P.62



LEGEND



M016

Aluminum

Base Service Package

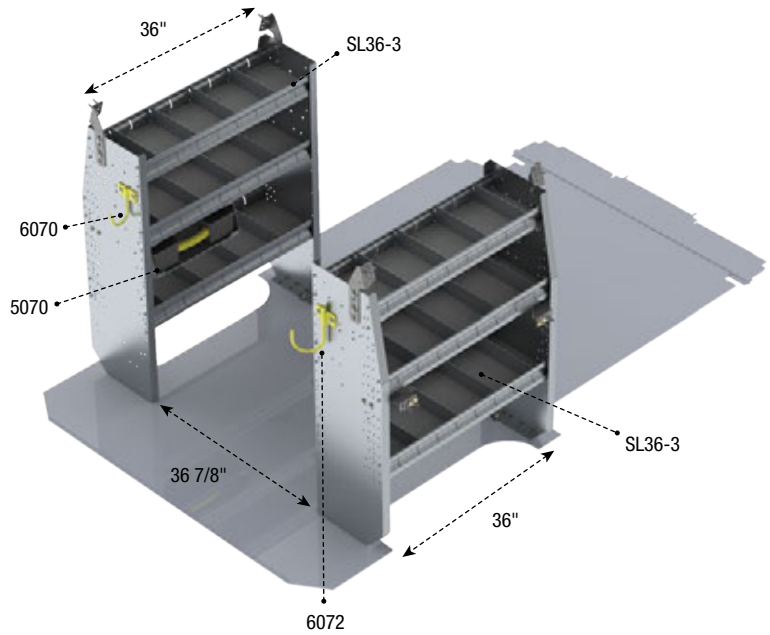

M016

Qty	Part #	Description
1	5070	Partskeeper case with shelf mount holder
1	6070	Large hook, fixed
1	6072	Large hook, swivel
2	SL36-3	Shelf unit, 36" L.

The **Base** package is designed to fit in a Metris with dual sliding doors.



96 lbs



2.7 hrs



Yes

ADD YOUR
ACCESSORIES
P.50



PICK YOUR
PARTITION
P.8



CHOOSE YOUR
LADDER RACK
P.62



M116

Aluminum

Deluxe Service Package

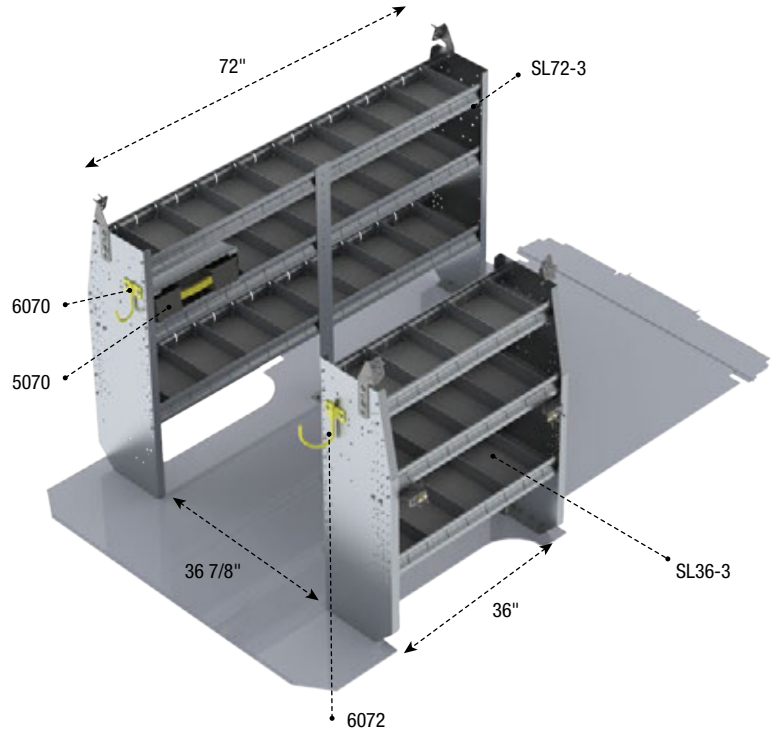

M116

Qty	Part #	Description
1	5070	Partskeeper case with shelf mount holder
1	6070	Large hook, fixed
1	6072	Large hook, swivel
1	SL36-3	Shelf unit, 36" L.
1	SL72-3	Shelf unit, 72" L.

The *Deluxe* package is designed to fit in a Metris with a single sliding door.



125 lbs



2.7 hrs



Yes

RANGER DESIGN PARTSKEEPER

The Ranger Design Partskeeper helps the mobile technician to take small parts anywhere on the job site and save return trips to the van. Removable bins included.

P.44





FRAGILE

MADE IN CANADA / FABRIQUÉ AU CANADA

RANGER

1-800-468-5521

FRA

MADE IN CANADA

RANGER

1-800-468-5521

M119

Delivery Package

TOUGH

Extrusion builds durability into shelf.

QUIET

The combination of the extrusion, shelf tray, and end-panels create durable, vibration-free shelves.

EFFICIENT

Ergonomic design reduces injuries and increases productivity.



*Preproduction model shown,
do not use as an installation guide.

M019

Aluminum

Base Delivery Package

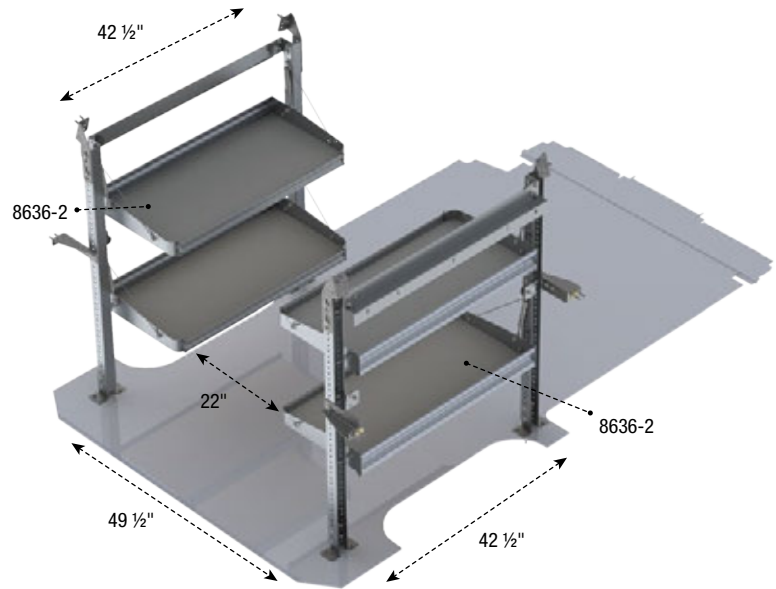

M019

Qty	Part #	Description
2	8636-2	Fold-Away Shelving Unit, 36"

The **Base** package is designed to fit in a Metris with dual sliding doors.

84 lbs

5.2 hrs

Yes

ADD YOUR
ACCESSORIES
P.50



PICK YOUR
PARTITION
P.8



CHOOSE YOUR
LADDER RACK
P.62



M119

Aluminum

Deluxe Delivery Package

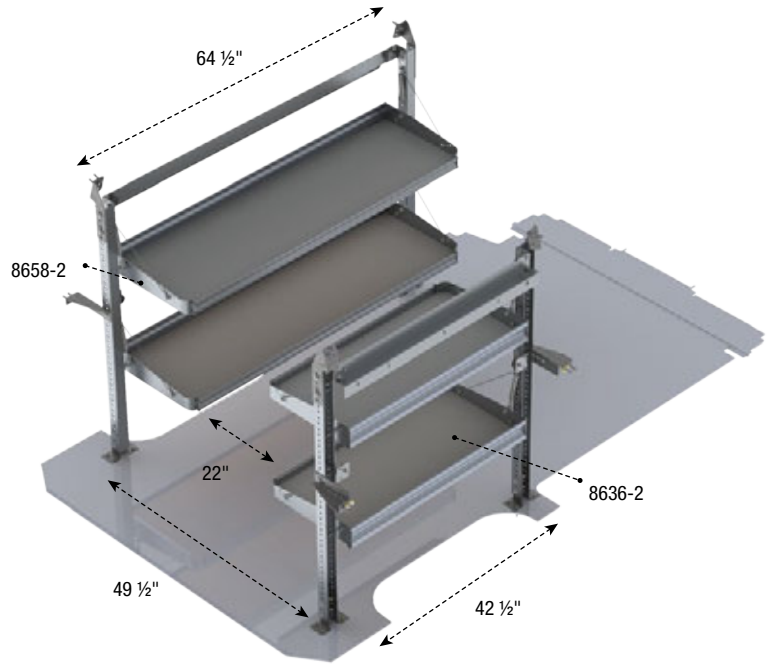

M119

Qty	Part #	Description
1	8636-2	Fold-Away Shelving Unit, 36"
1	8658-2	Fold-Away Shelving Unit, 58"

The *Deluxe* package is designed to fit in a Metris with a single sliding door.

88 lbs

5.2 hrs

Yes

NEW RANGER DESIGN MAX VIEW PARTITIONS

The Ranger Design Max View gives you 180 degree rear visibility into the cargo area – giving you the safety and comfort you deserve

P.9

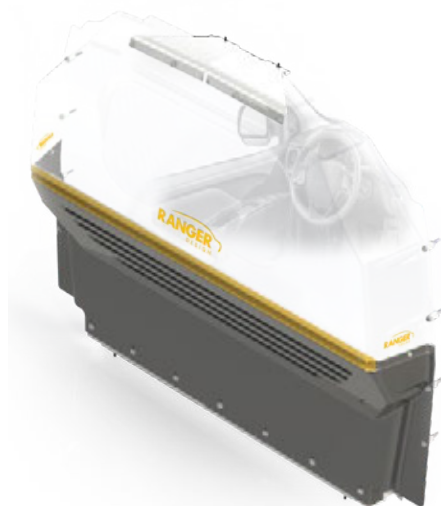

SHELVING

Industry leading strength.
The perfect fit for the toughest jobs.

CONTOURED UNITS

CONTOURED BIN SHELVING UNIT P. 35

CONTOURED REFRIGERANT BIN UNIT P. 35

CONTOURED SHELVING UNIT P. 36

CONTOURED SHELVING UNIT W/ DIVIDERS P. 36

DOORS P. 39

FOLD-AWAY SHELVING P. 36

SQUARE BACK UNITS

SQUARE BACK BIN SHELVING UNIT P. 35

WORKBENCHES P. 37

Ranger Design shelving is built strong and durable, and often outlasts the vehicle. Designed to fit with maximum efficiency, Ranger shelving optimizes the space in a work van's cargo area.

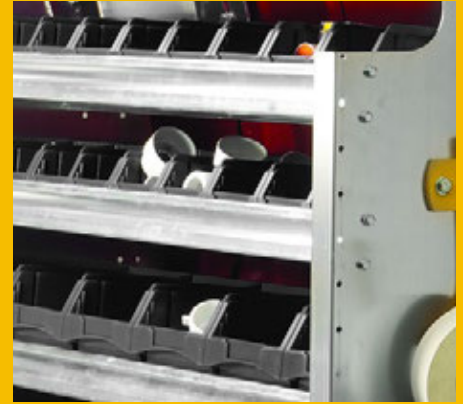

TOUGH
Extrusion builds durability into shelf.



QUIET
Shelf tray, end panel and extrusion are engineered to be vibration free.

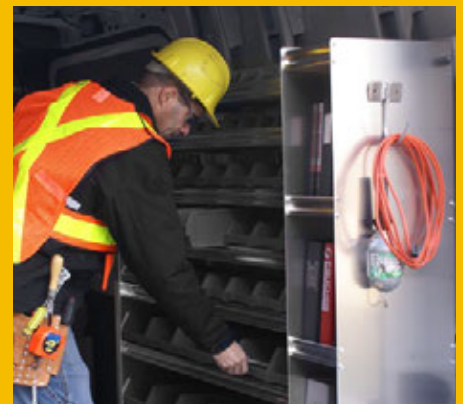







ORGANIZED
A well-planned van outfit increases productivity.

SQUARE BACK BIN SHELVING UNIT – SHELVING

Square Back Bin Shelving Unit







Aluminum

							
7848	11" D x 48" W x 13.25" H	25 lbs	2 Shelves (9", 9")	—	16 (md)	0.5 hr	No



Contoured Bin Shelving Unit







Aluminum

							
BL36	14" D x 36" W x 46" H	62 lbs			24 (md)	1 hr	Yes
BL48	14" D x 48" W x 46" H	76 lbs			32 (md)	1 hr	No
BL60	14" D x 60" W x 46" H	91 lbs			40 (md)	1 hr	No



Contoured Bin Shelving Unit





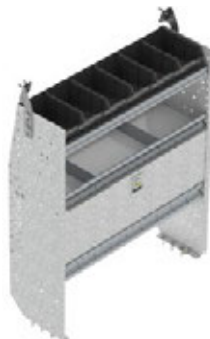

Steel

							
H36-L	14" D x 36" W x 46" H	58 lbs	3 Shelves (11", 13", 13")	4	6 (md)	1 hr	No
H48-L	14" D x 48" W x 46" H	68 lbs	3 Shelves (11", 13", 13")	6	8 (md)	1 hr	No
H60-L	14" D x 60" W x 46" H	79 lbs	3 Shelves (11", 13", 13")	8	10 (md)	1 hr	No



Contoured Bin Shelving Unit



Steel

							
H72-L	14" D x 72" W x 46" H	91 lbs	3 Shelves (11", 13", 13")	12	12 (md)	1 hr	No



Contoured Refrigerant Bin Unit

Aluminum







							
RL36	14" D x 36" W x 46" H	38 lbs			6 (md)	1 hr	Yes



SHELVING – CONTOURED SHELVING UNIT

Contoured Shelving Unit







Steel

							
L36-L	14" D x 36" W x 46" H	51 lbs	4 Shelves (11", 12", 13", 13")	—	—	1 hr	No
L48-L	14" D x 48" W x 46" H	59 lbs	4 Shelves (11", 12", 13", 13")	—	—	1 hr	No
L60-L	14" D x 60" W x 46" H	66 lbs	4 Shelves (11", 12", 13", 13")	—	—	1 hr	No
L72-L	14" D x 72" W x 46" H	76 lbs	4 Shelves (11", 12", 13", 13")	—	—	1 hr	No



Contoured Shelving Unit with Dividers







Aluminum

							
SL36-3	14" D x 36" W x 46" H	44 lbs	3 Shelves (11", 13", 13")	12	7723	1 hr	Yes
SL48-3	14" D x 48" W x 46" H	53 lbs	3 Shelves (11", 13", 13")	18	7720	1 hr	No
SL60-3	14" D x 60" W x 46" H	62 lbs	3 Shelves (11", 13", 13")	21	7722	1 hr	Yes
SL72-3	14" D x 72" W x 46" H	79 lbs	3 Shelves (11", 13", 13")	27	7723	1 hr	Yes



Contoured Shelving Unit with Dividers







Steel

							
F36-L	14" D x 36" W x 46" H	46 lbs	3 Shelves (11", 13", 13")	4	Y10-D	1 hr	Yes
F48-L	14" D x 48" W x 46" H	52 lbs	3 Shelves (11", 13", 13")	6	Y10-H	1 hr	No
F60-L	14" D x 60" W x 46" H	59 lbs	3 Shelves (11", 13", 13")	8	Y10-L	1 hr	No
F72-L	14" D x 72" W x 46" H	67 lbs	3 Shelves (11", 13", 13")	10	Y10-D	1 hr	Yes



Fold-Away Shelving

Aluminum







							
8636-2	18" D x 43" W x 50.5" H	42 lbs	2 Shelves (17", 17")	—	—	2.6 hrs	Yes
8658-2	18" D x 65" W x 50.5" H	46 lbs	2 Shelves (17", 17")	—	—	2.6 hrs	Yes

*Weight capacity for fold-away shelving is 65 lbs / linear foot.



Fold-Away Shelf Tray with Gas Shocks and Hardware

Aluminum







							
84-1830	18" D x 30" W	15 lbs	17"	—	—	0.4 hr	No
84-1836	18" D x 36" W	17 lbs	17"	—	—	0.4 hr	Yes
84-2130	21" D x 30" W	16 lbs	20"	—	—	0.4 hr	No
84-2136	21" D x 36" W	17 lbs	20"	—	—	0.4 hr	Yes

*Weight capacity for fold-away shelving is 65 lbs / linear foot.



Mounting Bar Assembly for Fold-Away Shelving

Aluminum

							
84-3033	2" D x 33" W	3 lbs	—	—	—	0.5 hr	No
84-3039	2" D x 39" W	3 lbs	—	—	—	0.5 hr	Yes

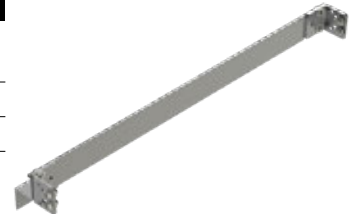

7207

Workbench w/hardwood top, no shelves

Aluminum

Universal



			
18" D x 48" W x 36" H	62 lbs	0.5 hr	No

7209

Workbench w/hardwood top, 1 shelf

Aluminum

Universal



			
18" D x 48" W x 36" H	74.2 lbs	1 hr	Yes

7208

Workbench w/hardwood top, one end panel
(Drawer cabinet not included)

Aluminum

Universal



			
18" D x 48" W x 36" H	47 lbs	0.5 hr	No



7248 Workbench w/hardwood top, 2 bin shelves

WORKBENCH – SHELVING

7210

Workbench w/hardwood top, 1 shelf w/door

Aluminum

Universal



18" D x 48" W x 36" H



75 lbs



1.2 hrs



No

7248

Workbench w/hardwood top, 2 bin shelves

Aluminum

Universal



18" P x 48" W x 28" H



91 lbs



1 hr



Yes

7211

Workbench w/hardwood top, 2 bin shelves

Aluminum

Universal



18" D x 48" W x 36" H



92.1 lbs



1 hr



Yes

7247

Workbench w/hardwood top, one end panel
(Drawer cabinet not included)

Aluminum

Universal



18" D x 48" W x 28" H



47 lbs



1 hr



No







7208 Workbench with hardwood top

SHELVING







Shelving Doors

Aluminum					
		Use with shelf width			
7720	44.88" W x 8.69" H	48", 96"	8 lbs	0.5 hr	No
7722	56.88" W x 8.69" H	60"	9 lbs	0.5 hr	No
7723	32.88" W x 8.69" H	36", 72"	6 lbs	0.5 hr	No
7724	20.88" W x 8.69" H	24"	4 lbs	0.5 hr	No
7725	44.88" W x 10.38" H	48", 96"	8 lbs	0.5 hr	Yes
7727	56.88" W x 10.38" H	60"	9 lbs	0.5 hr	No
7728	32.88" W x 10.38" H	36", 72"	6.5 lbs	0.5 hr	Yes
7729	20.88" W x 10.38" H	24"	4 lbs	0.5 hr	No
7730	44.88" W x 12.06" H	48", 96"	10 lbs	0.5 hr	Yes
7731	38.88" W x 12.06" H	84"	8 lbs	0.5 hr	No
7732	56.88" W x 12.06" H	60"	10 lbs	0.5 hr	No
7733	32.88" W x 12.06" H	36", 72"	6 lbs	0.5 hr	No
7734	20.88" W x 12.06" H	24"	5 lbs	0.5 hr	No
7735	44.88" W x 13.75" H	48", 96"	11 lbs	0.5 hr	No
7737	56.88" W x 13.75" H	60"	13 lbs	0.5 hr	No
7738	32.88" W x 13.75" H	36", 72"	7 lbs	0.5 hr	No
7739	20.88" W x 13.75" H	24"	5 lbs	0.5 hr	No







Shelf Block

Aluminum					
		Use with shelf width			
7740	12" W x Adjustable from 11" to 16.5"	All	3 lbs	0.5 hr	No





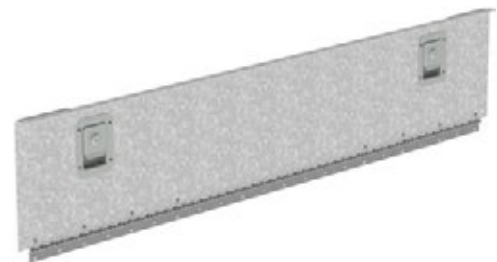

Shelving Doors

Steel					
		Use with shelf width			
Y10-C	34.88" W x 8.69" H	70"	8 lbs	0.5 hr	Yes
Y10-D	37.88" W x 8.69" H	38"	10 lbs	0.5 hr	No
Y10-F	41.88" W x 8.69" H	42", 87"	9 lbs	0.5 hr	Yes
Y10-H	47.88" W x 8.69" H	48"	14 lbs	0.5 hr	No
Y10-M	31.88" W x 8.69" H	32"	8 lbs	0.5 hr	No
Y11-C	34.88" W x 10.38" H	70"	10 lbs	0.5 hr	Yes
Y11-D	37.88" W x 10.38" H	38"	10 lbs	0.5 hr	Yes
Y11-E	35.88" W x 10.38" H	36"	10.5 lbs	0.5 hr	No
Y11-F	41.88" W x 10.38" H	42", 87"	13 lbs	0.5 hr	Yes
Y11-M	31.88" W x 10.38" H	32"	8 lbs	0.5 hr	No
Y12-C	34.88" W x 12.06" H	70"	10 lbs	0.5 hr	No
Y12-D	37.88" W x 12.06" H	38"	12 lbs	0.5 hr	No
Y12-F	41.88" W x 12.06" H	42", 87"	11 lbs	0.5 hr	No
Y12-M	31.88" W x 12.06" H	32"	8 lbs	0.5 hr	No



Shelving Doors

Steel					
		Use with shelf width			
Y10-J	55.88" W x 8.69" H	56"	15 lbs	0.5 hr	No
Y11-J	55.88" W x 10.38" H	56"	16 lbs	0.5 hr	No
Y12-J	55.88" W x 12.06" H	56"	17 lbs	0.5 hr	No



DRAWERS

Durable storage compartments, designed for quick and easy access.

AXESS TRAY	P. 41
COMPACT DRAWERS	P. 49
DRAWER CABINETS	P. 46
PARTSKEEPERS	P. 44
PARTSKEEPER CABINET	P. 44
PARTSLIDERS	P. 45
TOOL DRAWERS	P. 45

Ranger manufactures a variety of tough, quiet drawer systems and storage modules. Using top quality components such as full-extension, high-capacity ball-bearing drawer slides, secure locks, and Ranger's unique braided stainless steel cable-pull handles. These drawers are the organizational quality that you deserve.

If you never again want to experience the frustration of drawers that jam, sag, and don't latch properly, we have the solution.



TOUGH
Proline drawers are backed by a 10 year warranty.



QUICK
Easy to use slam latch.



SECURE
Keyed lock to guard valuables.



5032-0

Axess Tray with 1 shelf / no drawers

Aluminum

38" D x 45" W x 30" H

—

51 lbs

0.9 hr

No



5032-1

Axess Tray with 1 shelf / 1 drawer

Aluminum

38" D x 45" W x 30" H

200 lbs

89 lbs

1 hr

Yes



5032-2

Axess Tray with 1 shelf / 2 drawers

Aluminum

38" D x 45" W x 30" H

200 lbs

127 lbs

1.1 hrs

No



5032-3

Axess Tray with 1 shelf / 3 drawers

Aluminum

38" D x 45" W x 30" H

200 lbs

165 lbs

1.2 hrs

No



5032-A

Axess Tray drawer only, complete with slides

Aluminum

38" D x 45" W

—

38 lbs

—

No

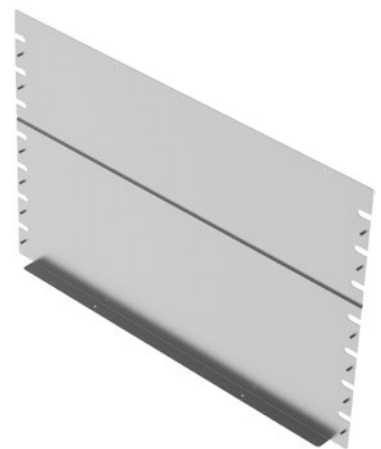

5032-F

Axess Tray full back panel for 5032 series

Aluminum

41" W x 27.25" H

—

8 lbs

0.25 hr

No

X51-F THE NEW STEEL 9-DRAWER CABINET WILL FIT IN ANY PACKAGE



BENEFIT

Ideal for securely storing and transporting small parts, the **X51-F** Steel 9 Drawer Cabinet is made of heavy duty steel and contains 9 plastic removable bin drawers. These van storage cabinets are also designed to be mounted side by side or stacked vertically to allow for fit in multiple layouts. Handy and easy to install, they come with mounting blocks for vertical stacking.



5037-0

Axess Tray with 1 shelf / no drawers

Aluminum

38" D x 45" W x 42" H

—

55 lbs

1 hr

No



5037-1

Axess Tray with 1 shelf / 1 drawer

Aluminum

38" D x 45" W x 42" H

200 lbs

93 lbs

1.1 hrs

No



5037-2

Axess Tray with 1 shelf / 2 drawers

Aluminum

38" D x 45" W x 42" H

200 lbs

131 lbs

1.2 hrs

No



5037-3

Axess Tray with 1 shelf / 3 drawers

Aluminum

38" D x 45" W x 42" H

200 lbs

169 lbs

1.3 hrs

No

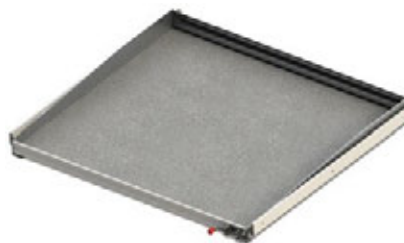

5037-A

Axess Tray drawer only, c/w slides

Aluminum

38" D x 45" W

—

38 lbs

—

No

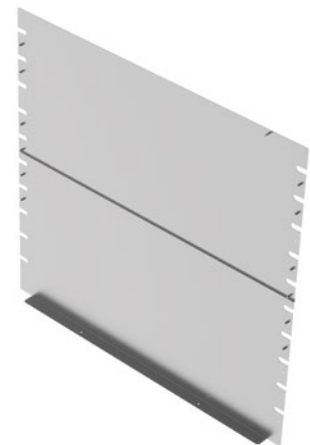

5037-F

Axess Tray full back panel for 5037 series

Aluminum

41" W x 39.25" H

—

11 lbs

0.25 hr

No

DRAWERS



5070

Partskeeper carry case with holder, universal

Aluminum

14" D x 17" W x 5.5" H

—

9 lbs

0.3 hr

Yes



5072

Partskeeper carry case with holder, floor mount

Aluminum

14" D x 17" W x 8.75" H

—

7 lbs

0.3 hr

No



5078

Partskeeper cabinet with 4 carry cases

Aluminum

14" D x 17" W x 24" H

—

34 lbs

0.3 hr

Yes

DRAWERS

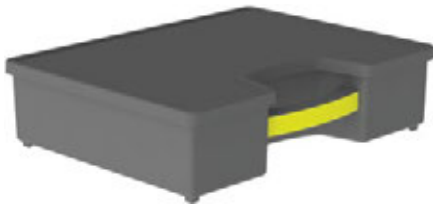

5079

Partskeeper carry case

Plastic

13" D x 16.5" W x 4" H

—

3 lbs

—

No



5082

Partskeeper cabinet with 8 carry cases

Aluminum

14" D x 17" W x 43" H

—

54 lbs

1 hr

Yes



5083

Partskeeper cabinet with 5 carry cases & 2 shelves

Aluminum

14" D x 17" W x 43" H

—

55 lbs

1 hr

Yes



5048

Top edge, for 5010 Partslider

Aluminum

48" D x 12" W x 4" H

—

7 lbs

0.2 hr

Yes

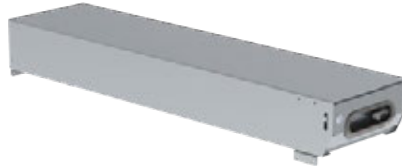

5010

Partslider drawer

Aluminum

48" D x 12" W x 6" H

150 lbs

31 lbs

0.5 hr

Yes



5011

Partslider drawer

Aluminum

36" D x 12" W x 6" H

150 lbs

24 lbs

0.5 hr

No



5014

Floor mount kit for 5010 / 5011 Partslider drawer

Aluminum

—

—

2 lb

—

Yes



5049

Top edge, for 5020 Partslider

Aluminium

48" D x 14" W x 4" H

—

5 lbs

0.2 hr

No



5050

Top edge, for 5025 Partslider

Aluminium

48" D x 16" W x 4" H

—

5 lbs

0.2 hr

No

DRAWERS

DRAWERS



5051

Top edge, for 5011 Tool drawer

Aluminium

36" D x 12" W x 4" H

—

5,6 lbs

0.2 hr

No



5052

Top edge, for 5021 Tool drawer

Aluminium

36" D x 14" W x 4" H

—

4 lbs

0.2 hr

No



5053

Top edge, for 5026 Tool drawer

Aluminium

36" D x 16" W x 4" H

—

4 lbs

0.2 hr

No



5057

Top edge, for 5060 Drawer cabinet

Aluminium

18" D x 24" W x 4" H

—

4 lbs

0.2 hr

No



5060-5

5 Drawer cabinet and 1 door

Aluminium

18" D x 24" W x 36" H

150 lbs

104 lbs

1 hr

Yes



5060-6

6 Drawer cabinet

Aluminium

18" D x 24" W x 36" H

150 lbs

126.5 lbs





1 hr

Yes



5060-8
8 Drawer cabinet





Aluminum

	18" D x 24" W x 36" H
	150 lbs
	148 lbs
	1 hr
	No



5067-6
6 Drawer cabinet





Aluminum

	18" D x 18" W x 28" H
	150 lbs
	97 lbs
	0.5 hr
	Yes



5068-3
3 Drawer cabinet

Aluminum

	18" D x 15" W x 15" H
	150 lbs
	45 lbs
	0.5 hr
	Yes



5020 Tool drawer mounted with its complementary **5010** Partslider drawer and **5048** Top edge.

DRAWERS



5069-2

2 Drawer cabinet

Aluminum

14" D x 24" W x 12" H

150 lbs

36 lbs

0.5 hr

Yes



5020

Tool drawer

Aluminum

48" D x 14" W x 16" H

320 lbs

70 lbs

1 hr

Yes



5021

Tool drawer

Aluminum

36" D x 14" W x 16" H

320 lbs

46 lbs

1 hr

No



5025

Jumbo tool drawer

Aluminum

48" D x 16" W x 19" H

320 lbs

67 lbs

1 hr

Yes



5026

Jumbo tool drawer

Aluminum

36" D x 16" W x 19" H

320 lbs

72 lbs

1 hr

No



5028

Raised base for 5020 tool drawer

Aluminum

6" D x 14" W x 6" H

—

7 lbs

0.5 hr

No



5029

Raised base for 5025 Jumbo tool drawer

Aluminum

6" D x 16" W x 6" H

—

8 lbs

0.5 hr

No



X50-B

Compact 2-Drawer Unit

Steel

12.5" D x 18.5" W x 10.5" H

—

27 lbs

0.3 hr

Yes



X50-C

Compact 3-Drawer Unit

Steel

12.5" D x 18.5" W x 10.5" H

—

29 lbs

0.3 hr

Yes



X51-F

Compact 9-Drawer Unit

Steel

12" D x 17" W x 12" H

—

26 lbs

0.3 hr

Yes



X02-A

Fleetline Tool Drawer

Steel

45.5" D x 13.5" W x 22" H

—

88 lbs

1 hr

Yes



X50-B and X50-C

ACCESSORIES

Choose the finishing details to tailor the upfit to your specific needs.

BINS	P. 51
BOTTLE HOLDERS	P. 52
HOOKS	P. 55
OTHERS	P. 54
PAPER HOLDERS	P. 56
SEAT COVERS	P. 61
WINDOW GRILLS	P. 60

The finishing details are just as important when you're setting up your commercial van as they are when you're on the job site. Customize your vehicle with our wide range of options to ensure that you can perform at peak efficiency.

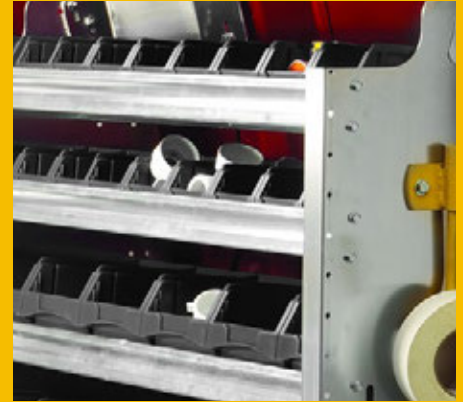

VERSATILE

Removable storage bins ensure organization on the jobsite or on the go.



SECURE

Trade specific accessories with a place for all tools and supplies.



PRODUCTIVE

Stay productive with the most used items well within reach.

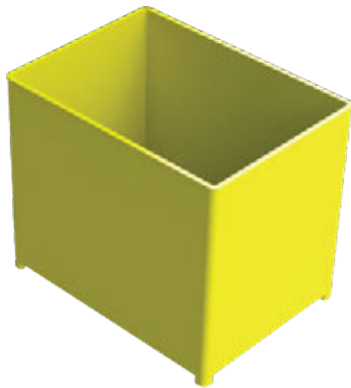

6205

Bin cup

Plastic

4.5" D x 3.25" W x 3.75" H

0.12 lb

-

No



6211

Small Bin, Graphite

Plastic

6.5" D x 4" W x 3" H

0.24 lb

-

Yes



6212

Divider for 6211 small bin

Aluminum

-

-

-

No



6221

Medium Bin, Graphite

Plastic

10" D x 6" W x 4.5" H

0.56 lb

-

Yes



6222

Divider for 6221 medium bin

Aluminum

-

-

-

No



6231

Large Bin, Graphite

Plastic

14" D x 8" W x 5.5" H

1.33 lbs

-

Yes

ACCESSORIES

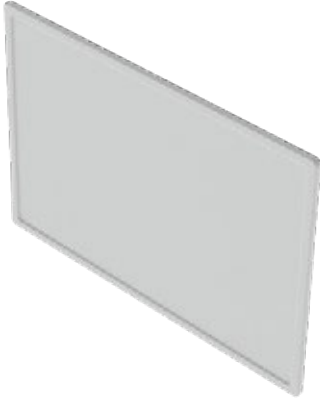

6232

Divider for 6231 large bin

Aluminum

-

-

-

No



6006

3 Tier refrigerant rack for small bottles

Aluminum

14" D x 10.5" W x 43" H

29 lbs

0.6 hr

No



6007

4 Tier refrigerant rack for small bottles

Aluminum

14" D x 10.5" W x 43" H

26 lbs

0.6 hr

Yes



6007 4 Tier refrigerant rack for small bottles

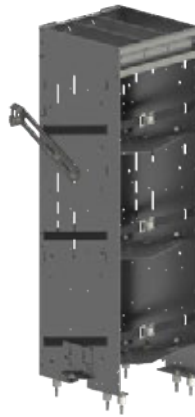

6008

3 Tier refrigerant rack for large bottles

Aluminum

14" D x 13" W x 43" H

25 lbs

0.6 hr

Yes



6010

Two level adjustable bottle holder

Aluminum

10.25" D x 9.5" W x 36" H





8 lbs

0.4 hr

Yes







6020
Horizontal refrigerant bottle holder

Aluminum	
	12.5" D x 48" W x 13" H
	17 lbs
	0.5 hr
	No







6030
Bottle rack with straps

Aluminium	
	48" W
	4 lbs
	0.5 hr
	No



6035
Bottle rack with straps

Aluminium	
	60" W
	6 lbs
	0.5 hr
	No

NEW RANGER DESIGN GRAPHITE BINS



BENEFIT
New graphite bin color provides a neutral balance that allows for more light and blends easily with existing colors.

ACCESSORIES

ACCESSORIES



6040

Locking cabinet

Aluminum

8.5" D x 12" W x 24" H

16 lbs

0.6 hr

No



6041

Locking cabinet

Aluminum

15" D x 15.5" W x 33" H

26 lbs

0.7 hr

No

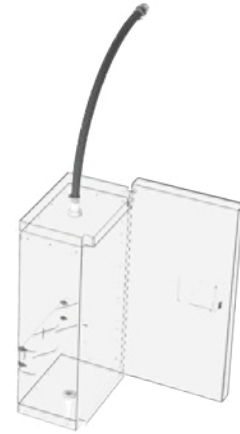

6049

Ventilation kit for cabinet

Aluminum

-

-

-

No

ACCESSORIES

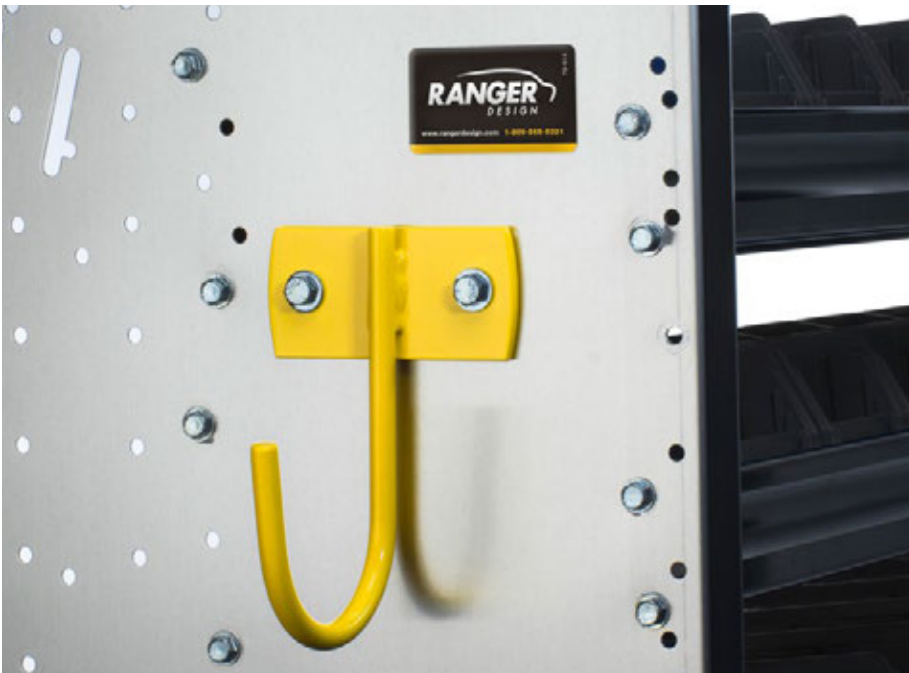

6070 6" Hook, 3" opening, painted



6088

Large aluminum bottle holder, with two black nylon straps

Aluminum

8" W x 24" H

5 lbs

0.2 hr

Yes



6086

Small aluminum bottle holder, comes with a black nylon strap

Aluminum

6" W x 12" H

1 lb

0.2 hr

Yes



6070

6" Hook, 3" opening, painted

Steel

3" D

2 lb

0.2 hr

Yes



6072

8" Swivel Hook, 4" opening, painted

Steel

4" D

3 lb

0.2 hr

Yes



6073

Large aluminum movable hook, 6.5" opening

Aluminum

6.5" D x 2.75" W x 4" H

1 lb

0.01 hr

Yes



Y30-C

Coat Hook, 1" opening, chrome plated

Steel

1" D

0.5 lb

0.2 hr

Yes



1130

Elevated strobe mount

Aluminum

8" W

1 lb

0.1 hr

No

ACCESSORIES

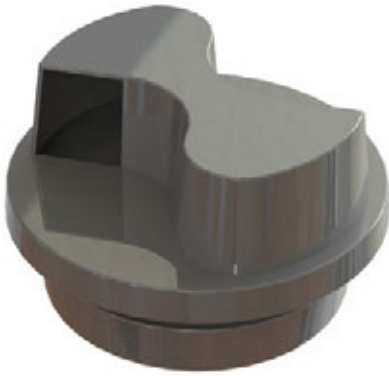

6050

Flettner vent, rotary design

Plastic

8.88" D

1.5 lbs

1 hr

No

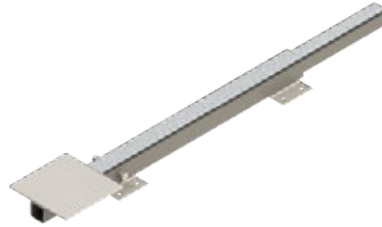

6052

Vise Holder with an 8"x8" mounting plate

Steel

—

37 lbs

0.5 hr

No



6054

Hitch Step, comes with hitch pin to fit a 2"x2" hitch

Aluminum

6" D x 12" W

4 lbs

—

No



6057

Can Holder

Aluminum

3" D x 8.5" W x 3" H

1 lb

0.2 hr

Yes



6061

Paper Holder, extra deep, 2 slots

Aluminum

3.75" D x 12.75" W x 12" H

2 lbs

0.2 hr

Yes



6063

Paper Holder, extra deep, 5 slots

Aluminum

3.75" D x 12.75" W x 24" H

7 lbs

0.2 hr

Yes



6066

2 Pocket Holder, comes with 8 plastic bins

Aluminum

4.5" D x 20" W x 21.75" H

7.5 lbs

0.2 hr

Yes



6067

Paper Holder, regular depth, 2 slots

Aluminum

2.25" D x 12.75" W x 12" H

3 lbs

0.2 hr

No



6068

Hard Hat Holder, painted wire

Steel

-

0.5 lb

0.2 hr

No



6069

Paper Holder, regular depth, 5 slots

Aluminum

2.25" D x 12.75" W x 24" H

7 lbs

0.2 hr

Oui

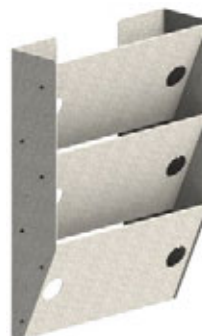

Y31-A

Paper Holder, extra deep, 3 slots

Steel

3.75" D x 12.75" W x 16" H

8.6 lbs

0.2 hr

Yes



6075

Transport tube door, for 6" diameter tube with stainless steel hardware

Aluminum

6" D

2 lbs

0.2 hr

No

ACCESSORIES



6078

Cradle & strap kit for 6" dia. transport tube (one cradle and one strap)

Aluminum

□ 6" D

⬆ 1 lb

🕒 0.1 hr

⚙ Yes

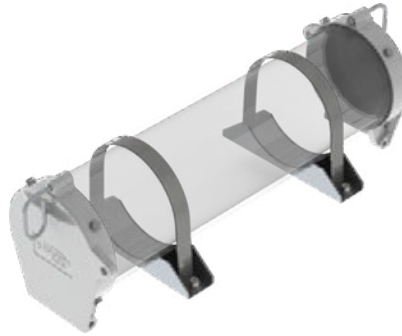

6079

Transport tube door kit complete (Tube not included)

Aluminum

□ 6" D

⬆ 8 lbs

🕒 0.8 hr

⚙ Yes



6082

Triangle kit with aluminum holder

Other

□ -

⬆ 14 lbs

🕒 0.2 hr

⚙ Yes



6090

Back up alarm, die cast housing, fully encapsulated circuitry

Other

□ -

⬆ 1 lb

🕒 1 hr

⚙ No



6091

Surface mount tie down ring, zinc plated

Steel

□ 4" D

⬆ 0.4 lb

🕒 0.2 hr

⚙ No



6092

Dome Light, chrome finish housing

Other

□ 8.5" D

⬆ 1 lb

🕒 1 hr

⚙ No



6093

Grab handle

Plastic

9.5" D

0.1 lb

0.5 hr

No



6095

Black nylon strap, plastic buckle

Other

2" W x 28" H

0.18 lb

0.01 hr

No



6096

Black Nylon Strap, chrome plated buckle

Other

1" W x 36" H

0.12 lb

0.01 hr

Yes



6097

Black Nylon Strap, chrome plated buckle

Other

1" W x 48" H

0.13 lb

0.01 hr

No



6098

Black Nylon Strap, chrome plated buckle

Other

1" W x 72" H

0.16 lb

0.01 hr

No



7124

Reel Holder with two 5/8" diameter rods

Aluminum

7.25" D x 15" W x 24" H

11 lbs

0.5 hr

Yes

ACCESSORIES



3024

Partition window with frame for 3020, 3025, 3068

Aluminum

Universal

5 lbs

—

No

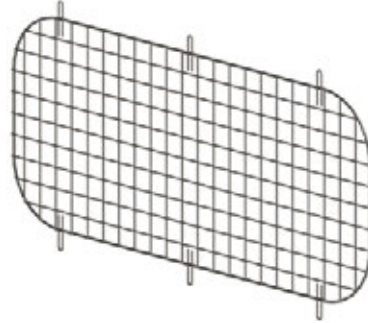

3044

Grill for partition window for 3020, 3025, 3068

Steel

Universal

2 lbs

—

No

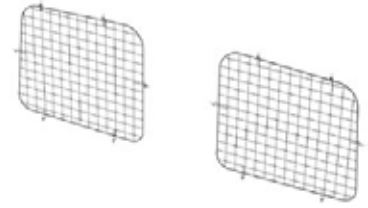

6126

Set of 2 rear window grills

Steel

Standard Roof

5 lb

0.2 hr

No



INTRODUCING THE NEW RANGER DESIGN

SEAT COVERS





OUR KEY ADVANTAGES INCLUDE:

- › Durable material and easy maintenance
- › Urethane coating to make the fabric water and stain resistant
- › Machine wash and dryer safe
- › Easy installation of 30 minutes or less for a set
- › No interference with factory seat functions (heating, cooling or air bag)
- › Minimal seams
- › Tight custom fit for each vehicle, guaranteed to stay in place
- › Puncture resistant to prevent seat damage
- › Durable Cordura® fabric with a 1 year warranty

6258

SPECIFICATIONS

for 1 set of bucket seat covers

	4 lbs
	0.5 hr
	Yes

THE PERFECT FIT
FOR YOUR TOUGHEST JOBS

RANGERTM
DESIGN

Our Promise: To Help You Work More Effectively by Providing Organized Storage Solutions.

LADDER RACKS

Ergonomic Ladder Racks make loading and unloading easier.

Ranger ladder racks make loading and unloading ladders an easy operation. Ranger Design offers drop-down ladder racks for high roof vans, extra tough racks capable of carrying 28' ladders on compact vans, interior ladder carriers and many other options for different applications.



RANGER
DESIGN



TOUGH

Military grade aluminum extrusion, high density plastic and stainless steel components ensure no corrosion over the lifetime of the rack.



QUIET

Aerodynamic design with minimal wind noise.



SAFE

No metal contact to ladder, leading to longer life of ladders with less chance of fiberglass splinters.



Cargo rack

Aluminum

1505-MM	64"	480 lbs	33 lbs	0.8 hr



Combination ladder rack

Aluminum

1525-MM	64"	400 lbs	64 lbs	1.7 hrs



Standard ladder rack

Aluminum

1510-MM	64"	400 lbs	33 lbs	0.9 hr



Double clamp ladder rack

Aluminum

1530-MM	64"	400 lbs	56 lbs	1.7 hrs



Single clamp ladder rack

Aluminum

1520-MM	64"	400 lbs	43 lbs	1.2 hrs



Ladder rack accessory

Aluminum

1127	—	—	18 lbs	0.5 hr

Over 350 Distributors Across the Continent

Regular Order

Quickship Order

Buy

Contact one of our 350 distributors
rangerdesign.com/find-dealer.

Ranger Quickship service is available
through your local distributor.

**Lead
Time**

Orders ship from our factory within
5 business days.

Orders placed with Ranger before 1PM EST will
ship from our factory in the next business day.



Throughout the catalog products and packages with this symbol
can be ordered through our Quickship service.

Turn-Key Fleet Services



Ship Through or Local Installation Across North America for all Types of Cargo Vans

We are pleased to offer efficient, personalized service and to answer all questions regarding:

1. Analysis

- › Cargo Needs Analysis
- › Custom 3D CAD Layouts
- › Hands-on Equipment Demo

2. Testing

- › Test Fitting
- › Pilot Build and Review
- › Optimize Package Based on Technician Feedback

3. Delivery

- › Delivery, Production and Installation Planning and Scheduling
- › Vehicle Status Tracking

4. Service

- › Dedicated Fleet Account Management Team
- › 300 Ranger Distributor Service Support Network
- › Live Customer Service

INDEX

1127	63	5083	44	7124	59	L48-L	36
1130	55	6006	52	7207	37	L60-L	36
1505-MM	63	6007	52	7208	37	L72-L	36
1510-MM	63	6008	52	7209	37	M011	18
1520-MM	63	6010	52	7210	38	M012	22
1525-MM	63	6020	53	7211	38	M016	28
1530-MM	63	6030	53	7247	38	M019	32
3024	60	6035	53	7248	38	M111	19
3044	60	6040	54	7720	39	M112	23
3320-MM	9	6041	54	7722	39	M116	29
5010	45	6049	54	7723	39	M119	33
5011	45	6050	56	7724	39	RL36	35
5014	45	6052	56	7725	39	SL36-3	36
5020	48	6054	56	7727	39	SL48-3	36
5021	48	6057	56	7728	39	SL60-3	36
5025	48	6061	56	7729	39	SL72-3	36
5026	48	6063	56	7730	39	X02-A	49
5028	48	6066	57	7731	39	X50-B	49
5029	49	6067	57	7732	39	X50-C	49
5032-0	41	6068	57	7733	39	X51-F	49
5032-1	41	6069	57	7734	39	Y10-C	39
5032-2	41	6070	55	7735	39	Y10-D	39
5032-3	41	6072	55	7737	39	Y10-F	39
5032-A	41	6073	55	7738	39	Y10-H	39
5032-F	41	6075	57	7739	39	Y10-J	39
5037-0	43	6078	58	7740	39	Y10-M	39
5037-1	43	6079	58	7848	35	Y11-C	39
5037-2	43	6082	58	84-1830	37	Y11-D	39
5037-3	43	6086	55	84-1836	37	Y11-E	39
5037-A	43	6088	54	84-2130	37	Y11-F	39
5037-F	43	6090	58	84-2136	37	Y11-J	39
5048	45	6091	58	84-3033	37	Y11-M	39
5049	45	6092	58	84-3039	37	Y12-C	39
5050	45	6093	59	8636-2	36	Y12-D	39
5051	46	6095	59	8658-2	36	Y12-F	39
5052	46	6096	59	BL36	35	Y12-J	39
5053	46	6097	59	BL48	35	Y12-M	39
5057	46	6098	59	BL60	35	Y30-C	55
5060-5	46	6126	60	C10-MM	9	Y31-A	57
5060-6	46	6205	51	C13-MM	9	Z10-M0	14
5060-8	47	6211	51	F36-L	36	Z10-M1	15
5067-6	47	6212	51	F48-L	36	Z16-M0	26
5068-3	47	6221	51	F60-L	36	Z16-M1	27
5069-2	48	6222	51	F72-L	36		
5070	44	6231	51	H36-L	35		
5072	44	6232	52	H48-L	35		
5078	44	6258	61	H60-L	35		
5079	44	6427	67	H72-L	35		
5082	44	6490	67	L36-L	36		



Product

Installation kits
for tool drawers

**Mercedes-Benz
Metris**

6427

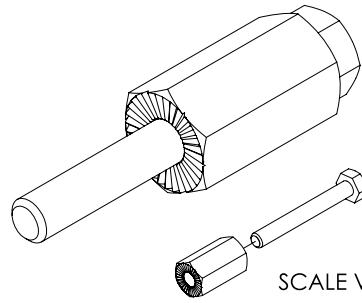

SCALE VIEW 3:1

The Plus Nut/Riv-Nut
tool (#6490) is available
at no charge upon request.



NEED HELP WITH YOUR ORDER

Contact us at cs@rangerdesign.com
or call **1-800-565-5321**

Ask us for our other Mercedes-Benz product
related catalogs.

Maximize Cargo Capacity & Vehicle Performance With Contractor Grade, Organized Storage Systems

When you want the perfect upfit solution for your work vehicle, turn to Ranger Design. Tested for toughness, Ranger's shelving and upfits will take whatever abuse you can dish out. Their unsurpassed craftsmanship, combined with ideal fit and finish, provide a quiet ride with no rattles.



CUSTOMER SERVICE

cs@rangerdesign.com
1-800-565-5321
rangerdesign.com



THE PERFECT FIT
FOR YOUR TOUGHEST JOBS