

2017



BUYERS' **GUIDE**

RANGERTM
DESIGN

Helping Mobile Technicians Work More Effectively by Providing Organized Storage Solutions

At Ranger Design, we believe more is possible.

We believe work vehicles and the technicians that drive them can become more organized, more efficient, more productive and more profitable. At Ranger Design we're committed to bringing you the products and services that make that possible.

More means helping you choose the right work van for your

application, as well as giving you engineering support and expert advice to help design the most efficient work space in your new vehicle.

More also means getting that new van outfitted and on the road faster, so you can start using it for the reason you bought it.

We're committed to bringing you more, because we believe more is possible.



MORE IS POSSIBLE



TABLE OF CONTENTS

INSTALL TIMES

Install time is estimated based on the average time taken by an experienced Ranger Design installer.

UPDATED DATA

At the moment of publication, the data included in this directory was up-to-date.

Any corrections, modifications and discontinued product occurring after publication date are reflected in our Buyers' Guide available on our website.

The digital version of all our catalogs is always updated as modifications occur during the year.

CHOOSE A PRODUCT LINE	P. 4
HOW TO BUY	P. 6
GETTING STARTED	P. 8
PLAN YOUR VAN OUTFIT – LAYOUT GUIDES	P. 10
FLOORS	P. 22
PARTITIONS	P. 24
PACKAGES	P. 48
SHELVING	P. 172
DRAWERS	P. 212
ACCESSORIES	P. 224
LADDER RACKS	P. 234
INSTALL KITS	P. 266
INDEX	P. 268

Choose A Product Line To Match Your Needs

Ranger Fleetline and Proline product groups ensure that fleets of any size have the best equipment to fit their budget, trade or fuel saving targets.



Ranger Fleetline shown



Ranger Proline shown

	MATERIAL	BENEFITS	PRODUCTS	WARRANTY
<p>WHY BUY RANGER FLEETLINE? You want better quality and price than other steel products on the market.</p>	Steel	Tough Low cost Quiet	Shelving, Partitions, Drawers, Accessories	3 years*
<p>WHY BUY RANGER PROLINE? You want the toughest, quietest product on the market. You need to optimize payload without sacrificing quality.</p>	Aluminum	Toughest Lightweight Quiet	Shelving, Partitions, Drawers, Accessories, Ladder Racks	10 years*

*Ranger Design Inc. van equipment is warranted to be free from defects in material and workmanship under normal use and service for the period indicated, from the date of the original retail purchase, when installed per Ranger Design instructions in the original vehicle. Please contact Customer Service for full warranty details. Email: cs@rangerdesign.com

Throughout the catalog **FLEETLINE** products are depicted with yellow and **PROLINE** products with black.

1-800-565-5321
7 A.M. – 8 P.M. EST

World Class Customer Service



Real people, ready to answer in 2 rings or less*

We are pleased to offer efficient, personalized service and to answer all questions regarding:

- › Pricing/Quoting
- › Product install
- › Order status
- › Consultation
- › Shipment status
- › New product availability
- › Product specifications
- › Warranty claims
- › Returns/Restocking
- › Vehicle specifications

*Call customer service and the phone will be answered in 2 rings or less. Yes, a real, live person working in one of our offices in North America is available to answer your questions. No automated attendant. No complicated phone tree and offshore service. Call us to experience the difference.

Over 350 Distributors Across the Continent

Regular Order

Quickship Order

Buy

Contact one of our 350 distributors
rangerdesign.com/find-dealer.

Ranger Quickship service is available
through your local distributor.

**Lead
Time**

Orders ship from our factory within
5 business days.

Orders placed with Ranger before 1PM EST will
ship from our factory in the next business day.



Throughout the catalog products and packages with this symbol
can be ordered through our Quickship service.

Turn-Key Fleet Services



Ship Through or Local Installation Across North America for all Types of Cargo Vans

We are pleased to offer efficient, personalized service and to answer all questions regarding:

1. Analysis

- › Cargo Needs Analysis
- › Custom 3D CAD Layouts
- › Hands-on Equipment Demo

2. Testing

- › Test Fitting
- › Pilot Build and Review
- › Optimize Package Based on Technician Feedback

3. Delivery

- › Delivery, Production and Installation Planning and Scheduling
- › Vehicle Status Tracking

4. Service

- › Dedicated Fleet Account Management Team
- › 300 Ranger Distributor Service Support Network
- › Live Customer Service

Take a few minutes to write down these simple steps

Plan your storage zones

For how long do you plan to use the vehicle? A year 2–5 years 10 years or more (see page 4)

Will payload capacity be an issue? Yes No Why? _____

What type of industry are you in? _____

What kind of partition do I need? (F zone)

Do I need to see my cargo or see out the side doors? Yes No

Do I need the ability to go from the cabin to the cargo area through the partition? Yes No

List the equipment/products you will need to store

Place the items that you need most often in the most accessible locations.

	How often will you use this?			Zone
	Daily	Weekly	Monthly	
_____	<input type="checkbox"/>	<input type="checkbox"/>	<input type="checkbox"/>	A - B - C - D - E
_____	<input type="checkbox"/>	<input type="checkbox"/>	<input type="checkbox"/>	_____
_____	<input type="checkbox"/>	<input type="checkbox"/>	<input type="checkbox"/>	_____
_____	<input type="checkbox"/>	<input type="checkbox"/>	<input type="checkbox"/>	_____
_____	<input type="checkbox"/>	<input type="checkbox"/>	<input type="checkbox"/>	_____

Will I need to carry larger objects Yes No

List the tools you will need to carry

Place heavy tools closest to the access doors.

	How often will you use this?			Zone
	Daily	Weekly	Monthly	
_____	<input type="checkbox"/>	<input type="checkbox"/>	<input type="checkbox"/>	A - B - C - D - E
_____	<input type="checkbox"/>	<input type="checkbox"/>	<input type="checkbox"/>	_____
_____	<input type="checkbox"/>	<input type="checkbox"/>	<input type="checkbox"/>	_____
_____	<input type="checkbox"/>	<input type="checkbox"/>	<input type="checkbox"/>	_____
_____	<input type="checkbox"/>	<input type="checkbox"/>	<input type="checkbox"/>	_____

What kind of ladder(s) will I be carrying? Step ladder Extension ladders
 Size _____ Size _____

Storage Zones

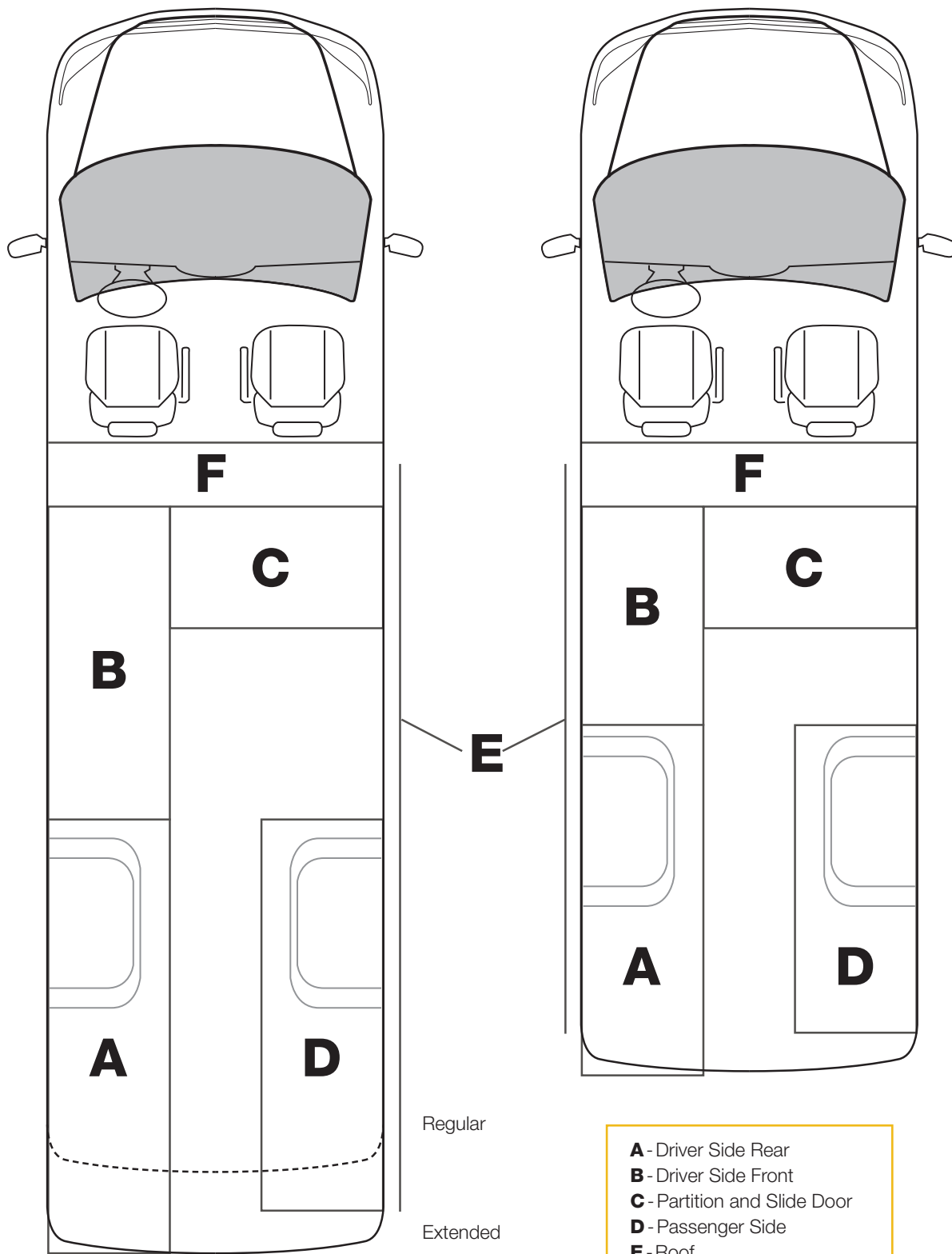

- A** - Driver Side Rear
- B** - Driver Side Front
- C** - Partition and Slide Door
- D** - Passenger Side
- E** - Roof
- F** - Partition

How to use the layout guide

INSIDE ROOF HEIGHT

To determine the maximum shelf height that can be used in the van.

PARTITION DEPTH

This indicates the space taken up by our partition for this vehicle. Please note that this measurement is determined by the partition that encroaches the most. Some partitions may take up less space. Take note that this measurement may not necessarily be on the floor.

DOOR OPENING

To determine where shelving will land in relation to the door opening. Use this measurement to determine the space available for drawer units.

DIMENSIONS IN RED

These dimensions indicate unique measurements for each wheelbase. Use red dimensions to determine the exact wheelbase of your van.

FLOOR SPACE

This area is usable floor space but due to curvature of the van there may not be the same available area at the roof. Please measure actual van for specific measurement at roof.

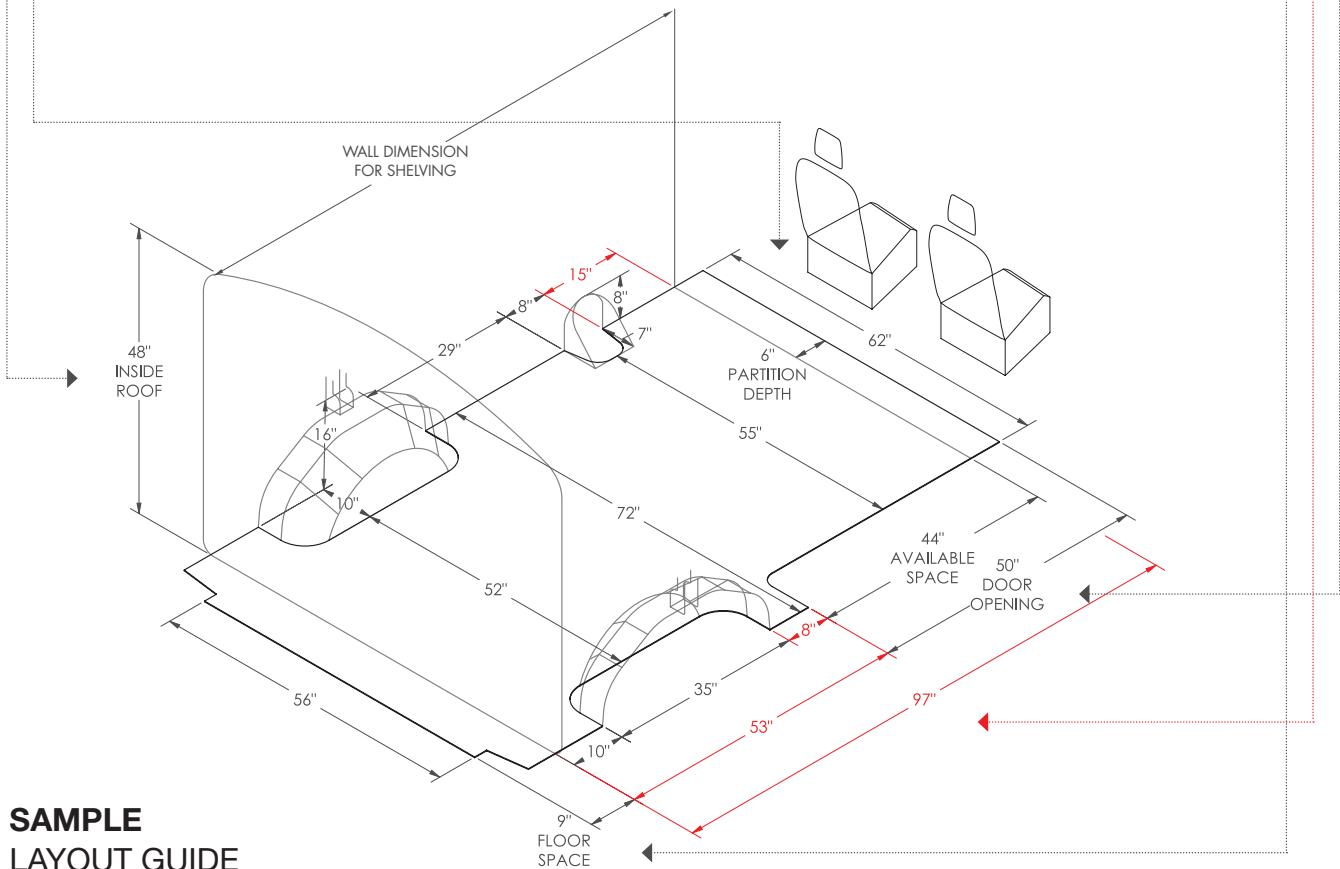

SAMPLE LAYOUT GUIDE

Wheelbase

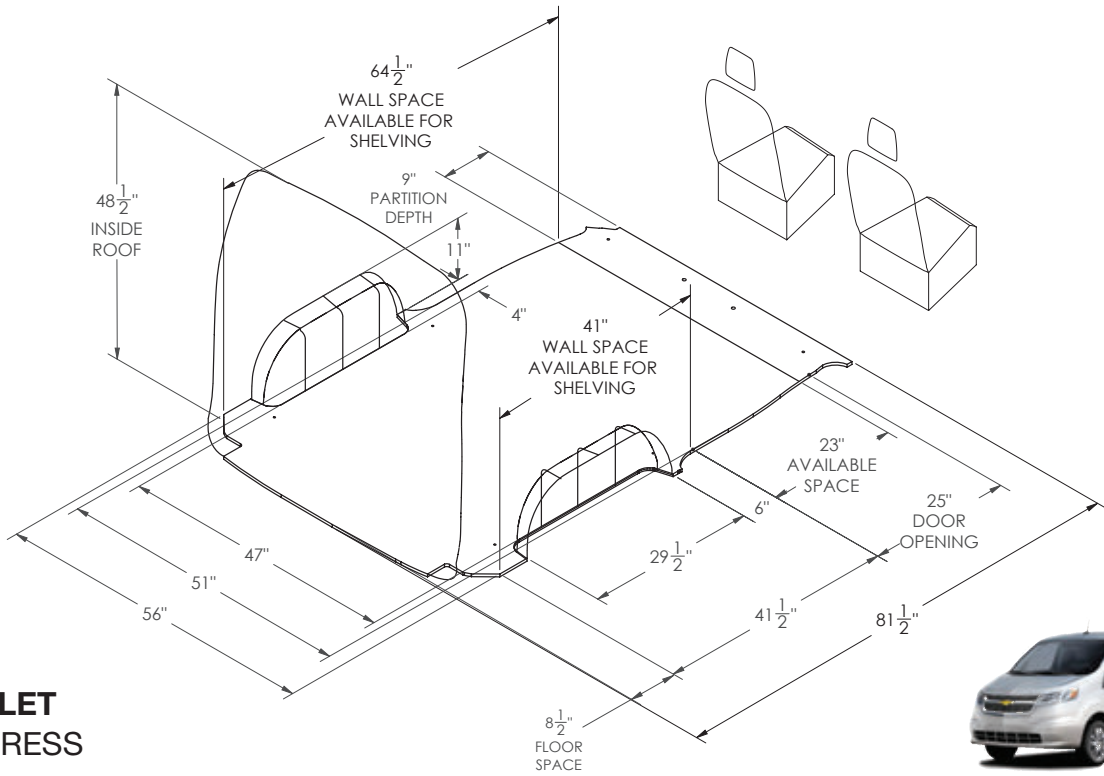

CHEVROLET CITY EXPRESS

Regular 115" Wheelbase

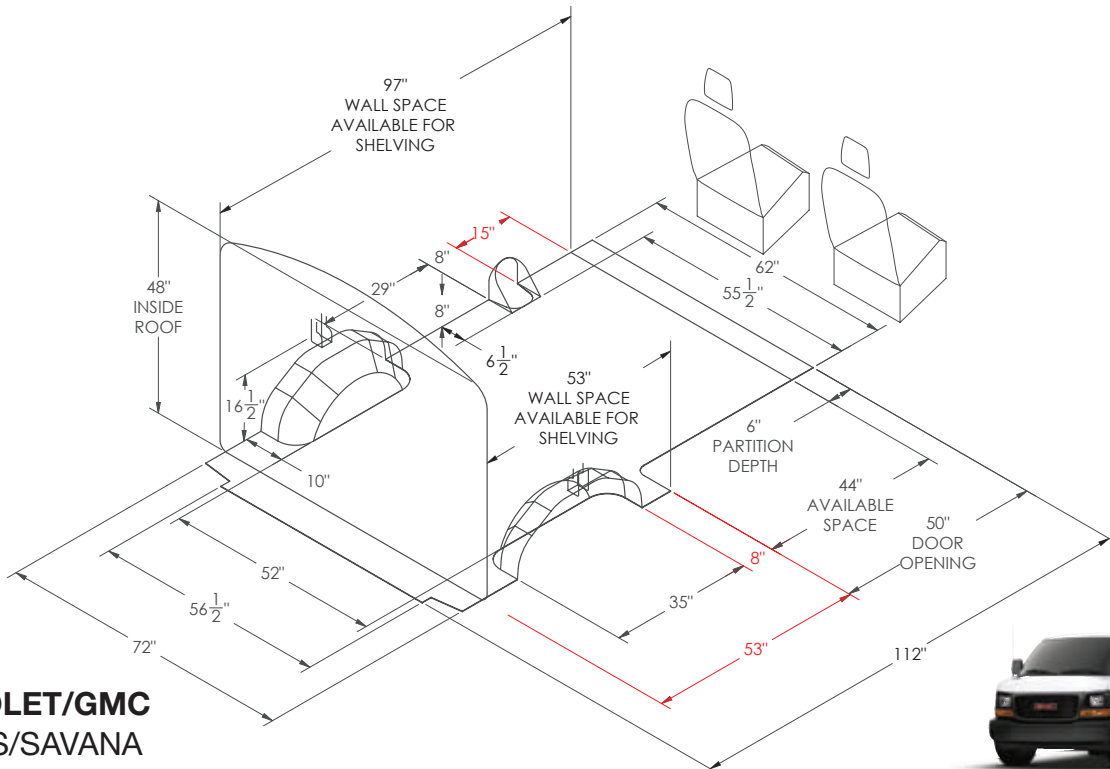

CHEVROLET/GMC EXPRESS/SAVANA

Regular 135" Wheelbase



LAYOUT GUIDES

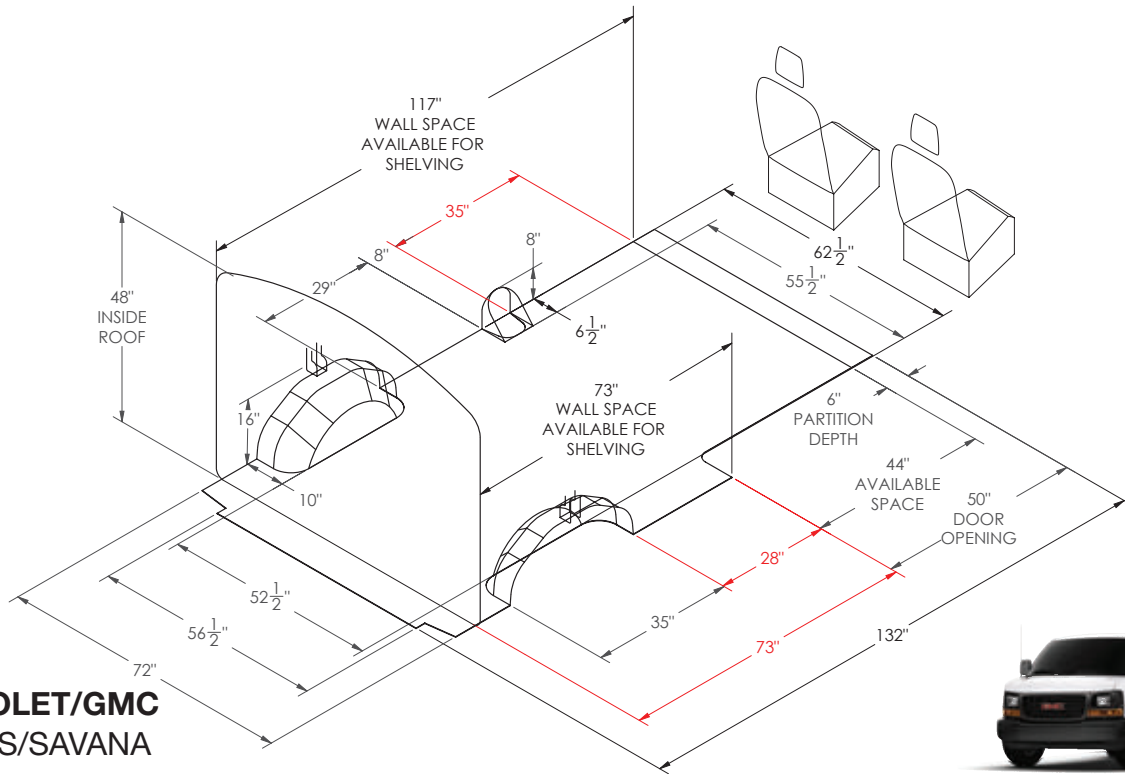

CHEVROLET/GMC EXPRESS/SAVANA

Extended 155" Wheelbase

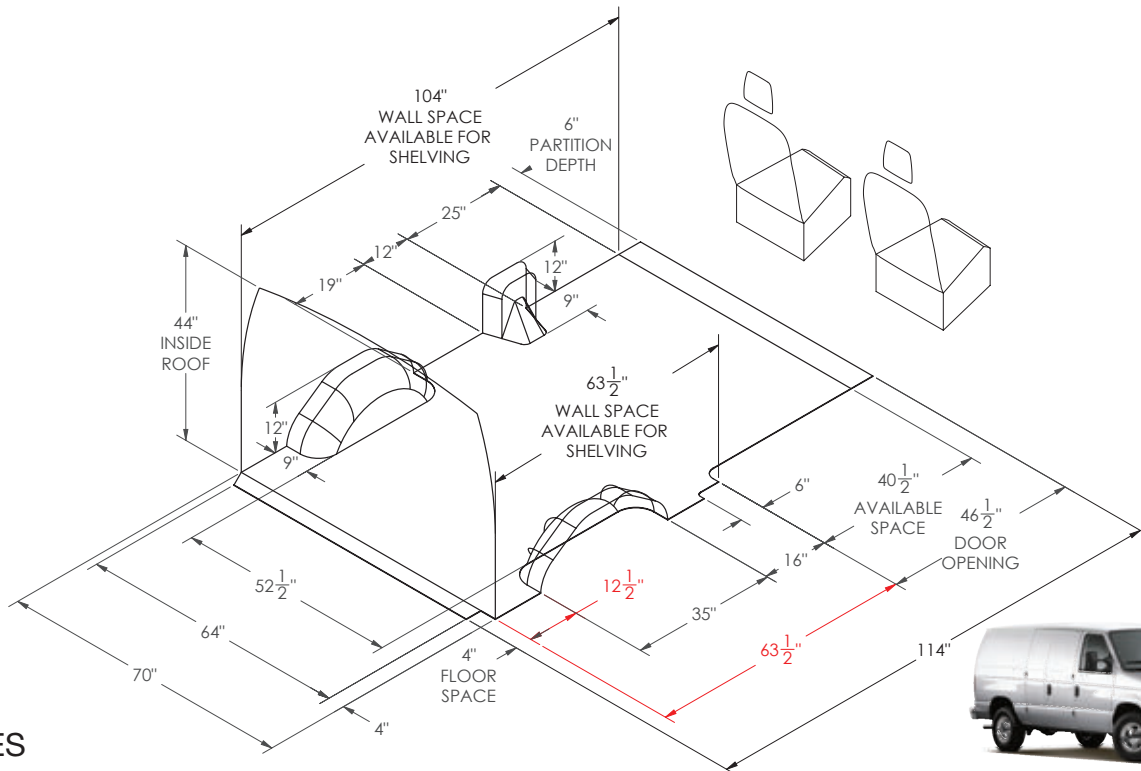

FORD E-SERIES

Regular 138" Wheelbase



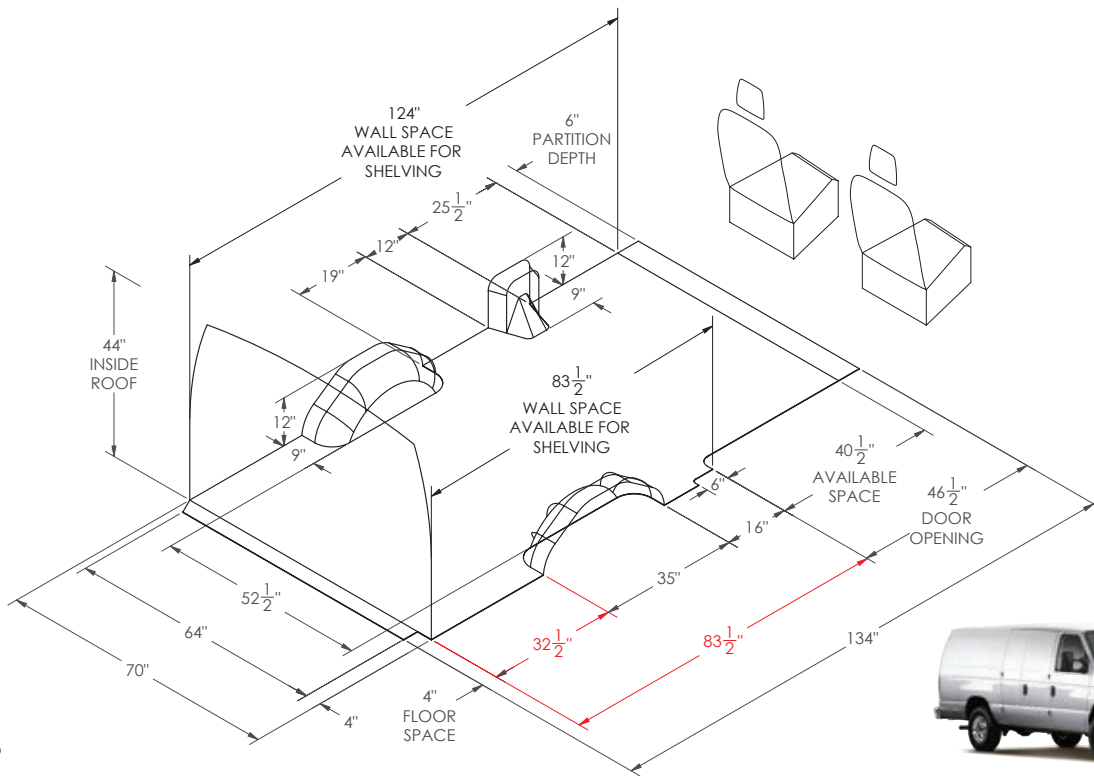

FORD E-SERIES

138" Wheelbase Extended

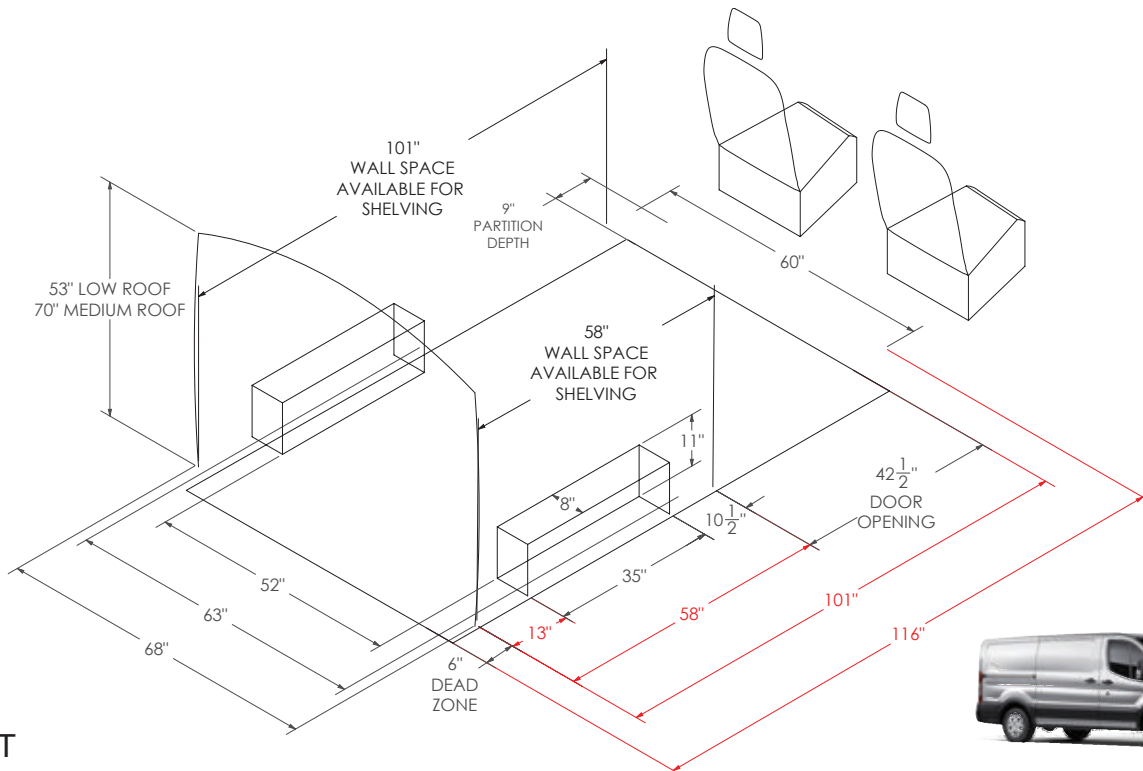

FORD TRANSIT

Regular 130" Wheelbase



LAYOUT GUIDES

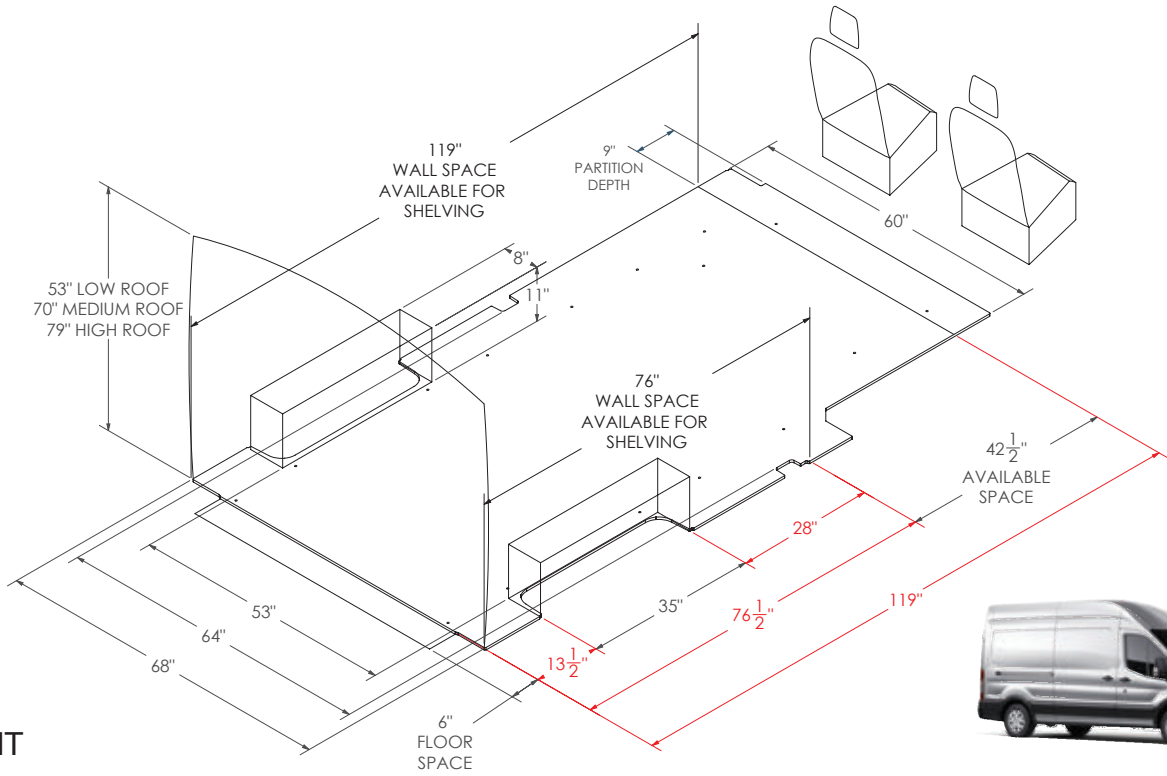

FORD TRANSIT

Long 148" Wheelbase

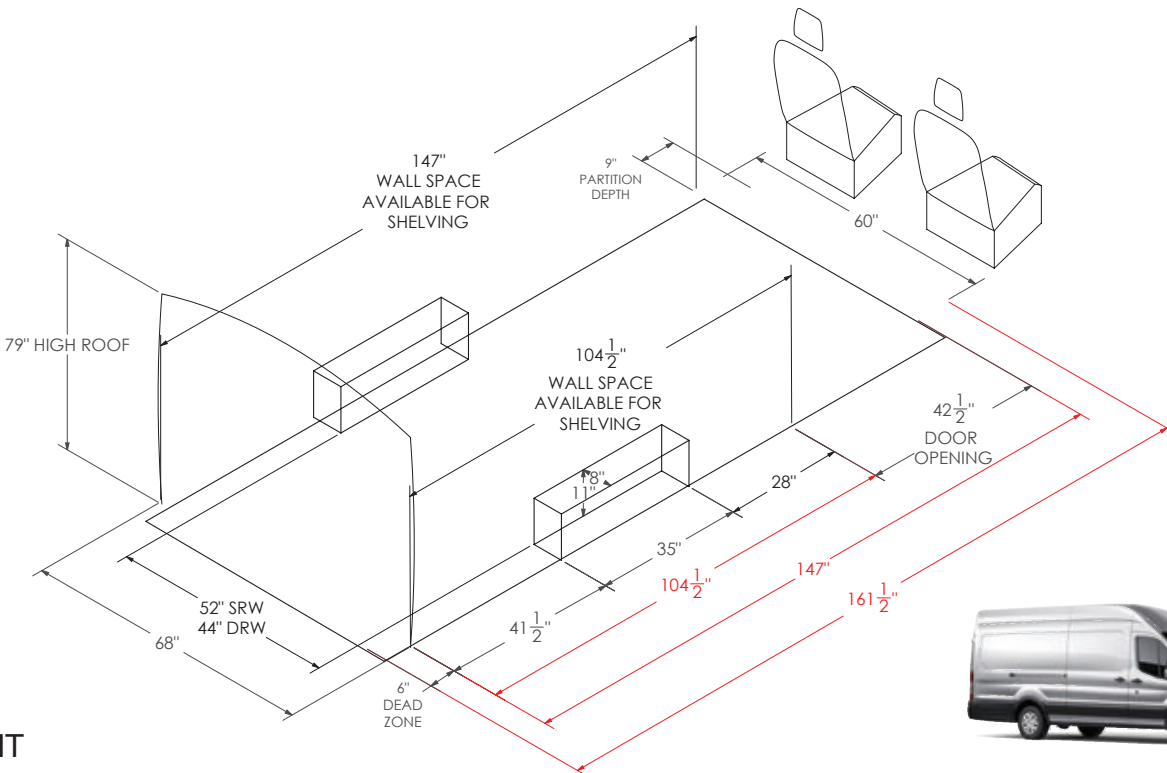

FORD TRANSIT

Long 148" Wheelbase Extended

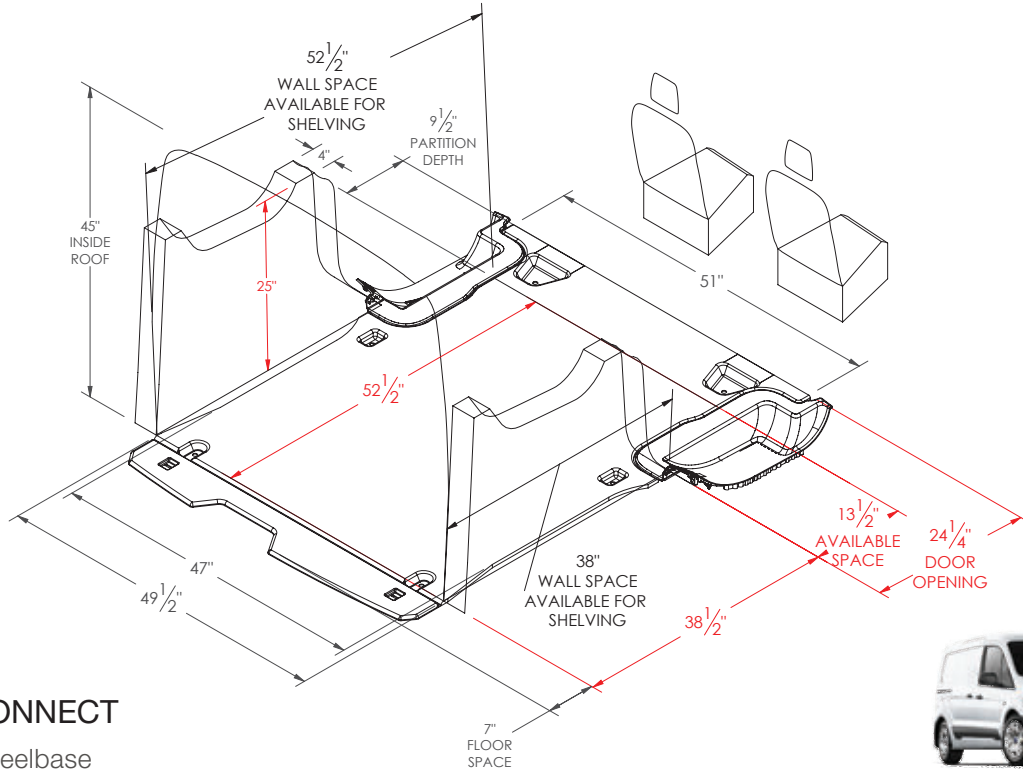

FORD TRANSIT CONNECT

Short 105" Wheelbase
Available in U.S. only

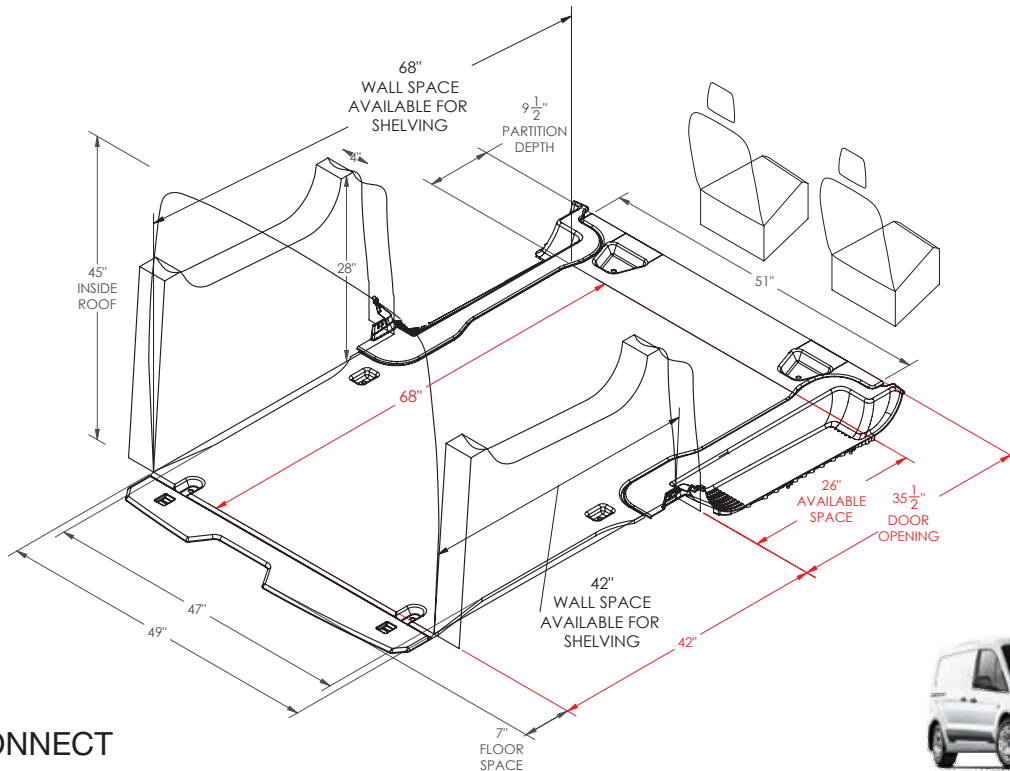

FORD TRANSIT CONNECT

Long 120.5" Wheelbase

LAYOUT GUIDES

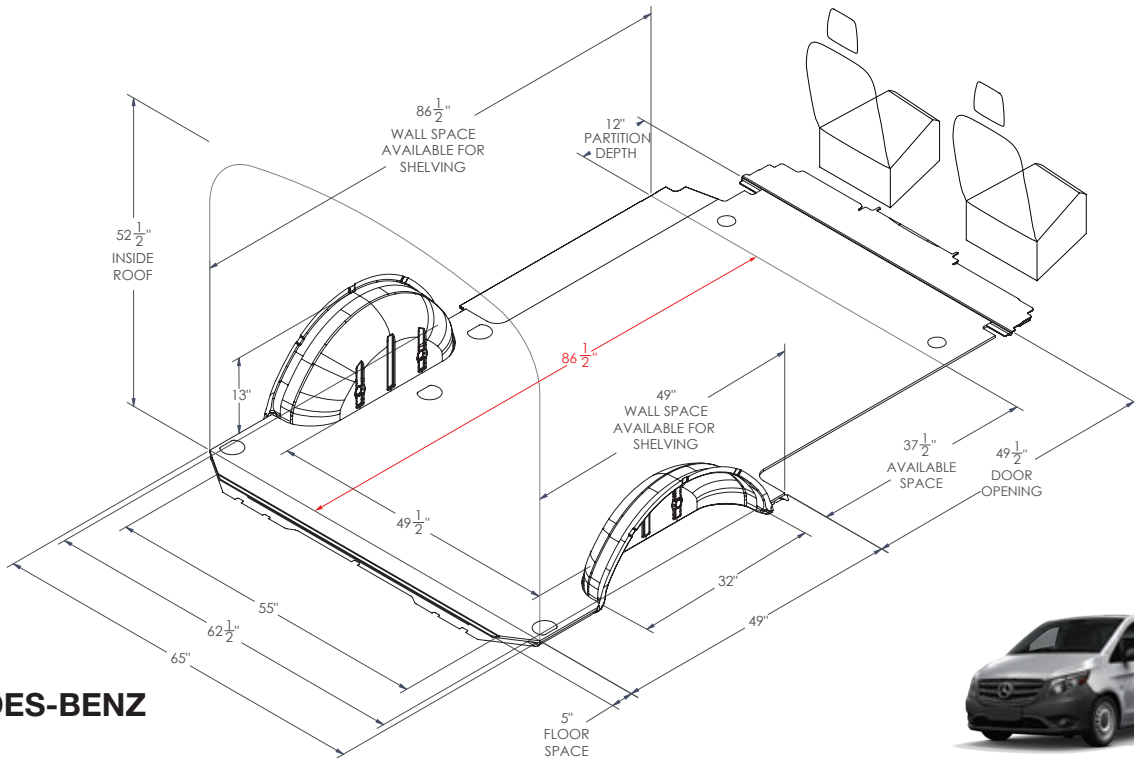

MERCEDES-BENZ METRIS

Regular 126" Wheelbase

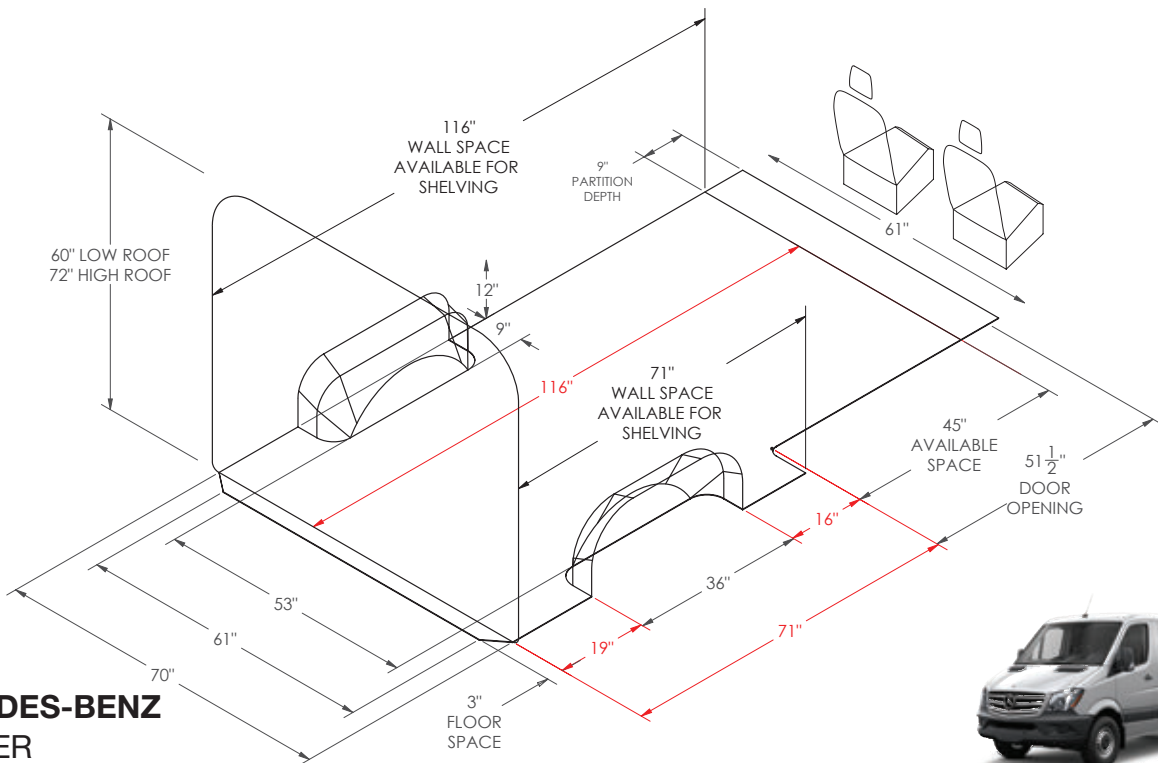

MERCEDES-BENZ SPRINTER

Regular 144" Wheelbase

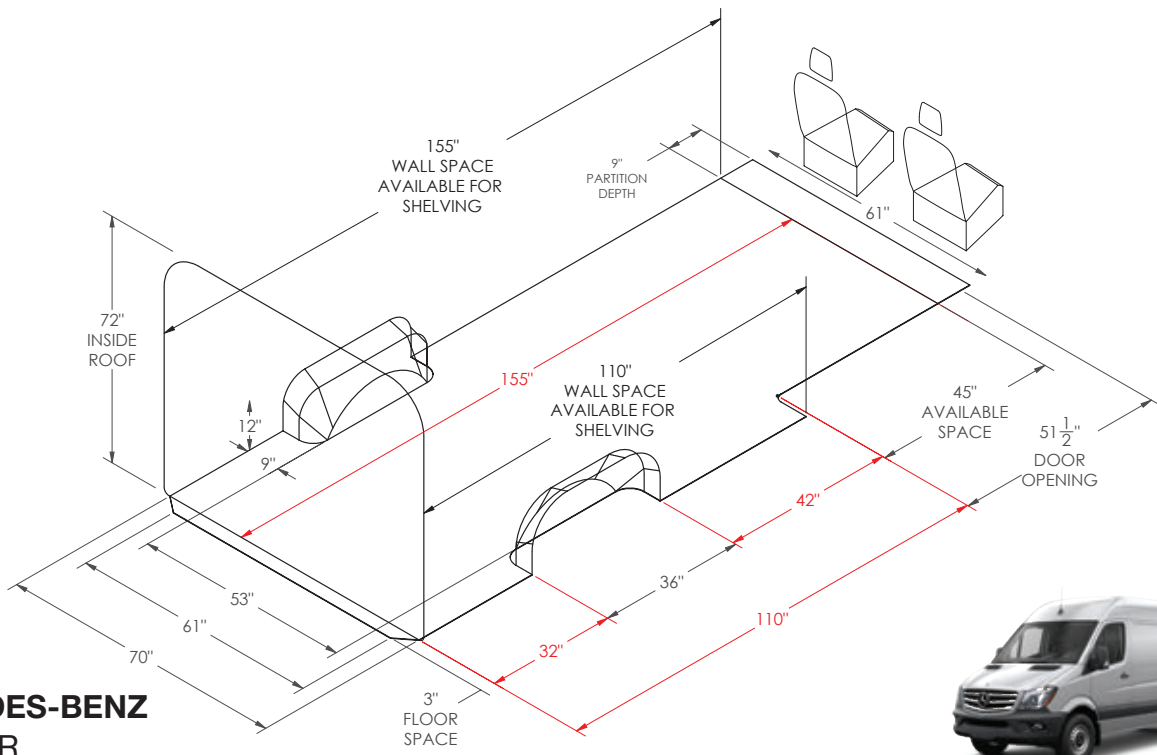

MERCEDES-BENZ SPRINTER

Long 170" Wheelbase

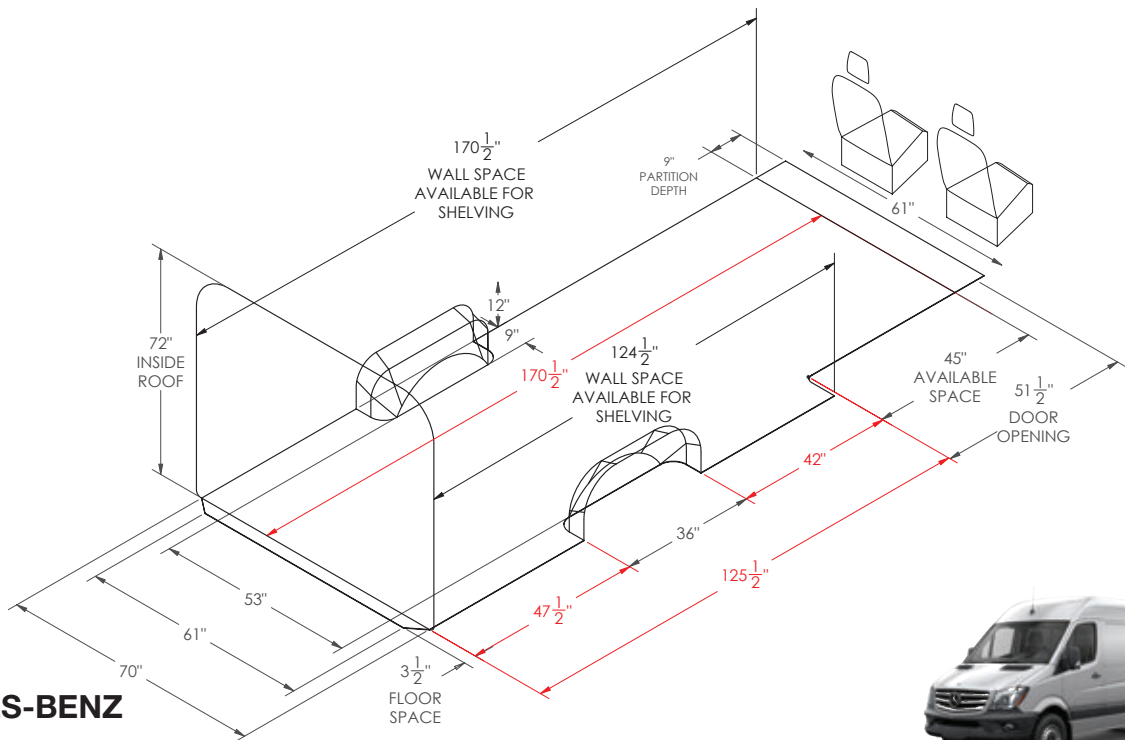

MERCEDES-BENZ SPRINTER

Extended 170" Wheelbase



LAYOUT GUIDES

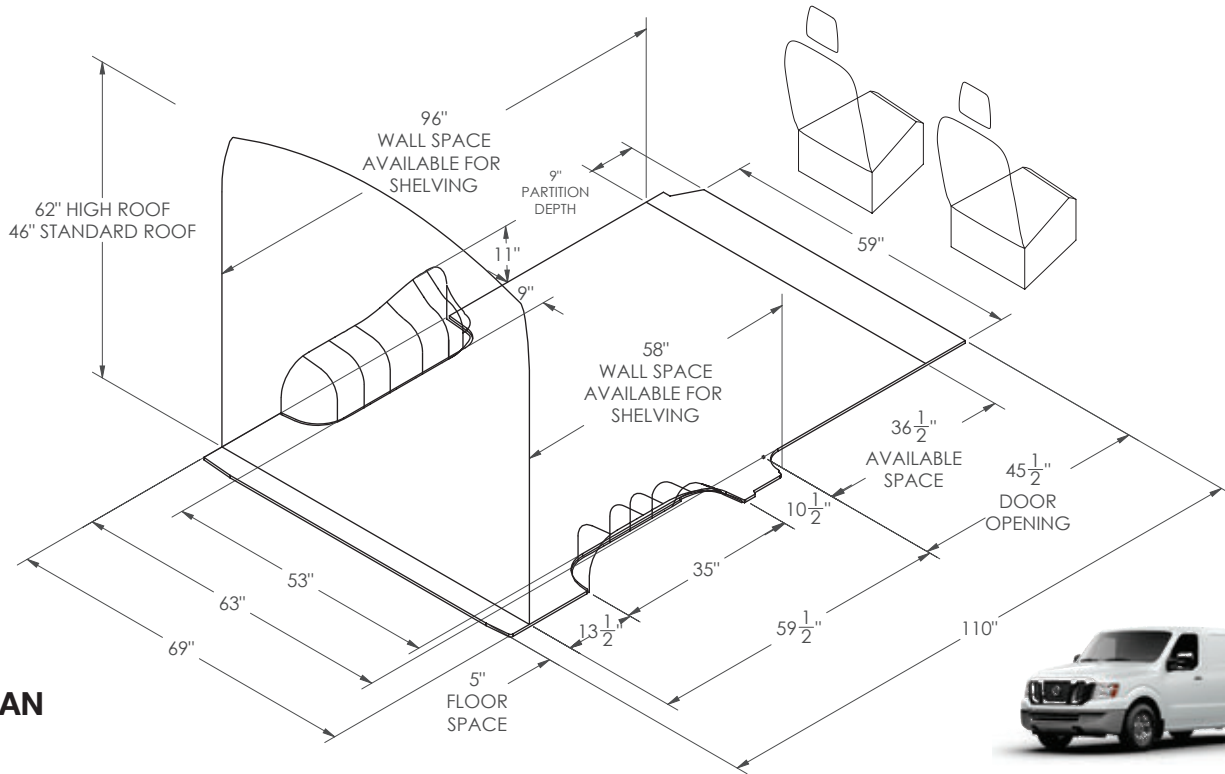

NISSAN NV

Standard 146" Wheelbase

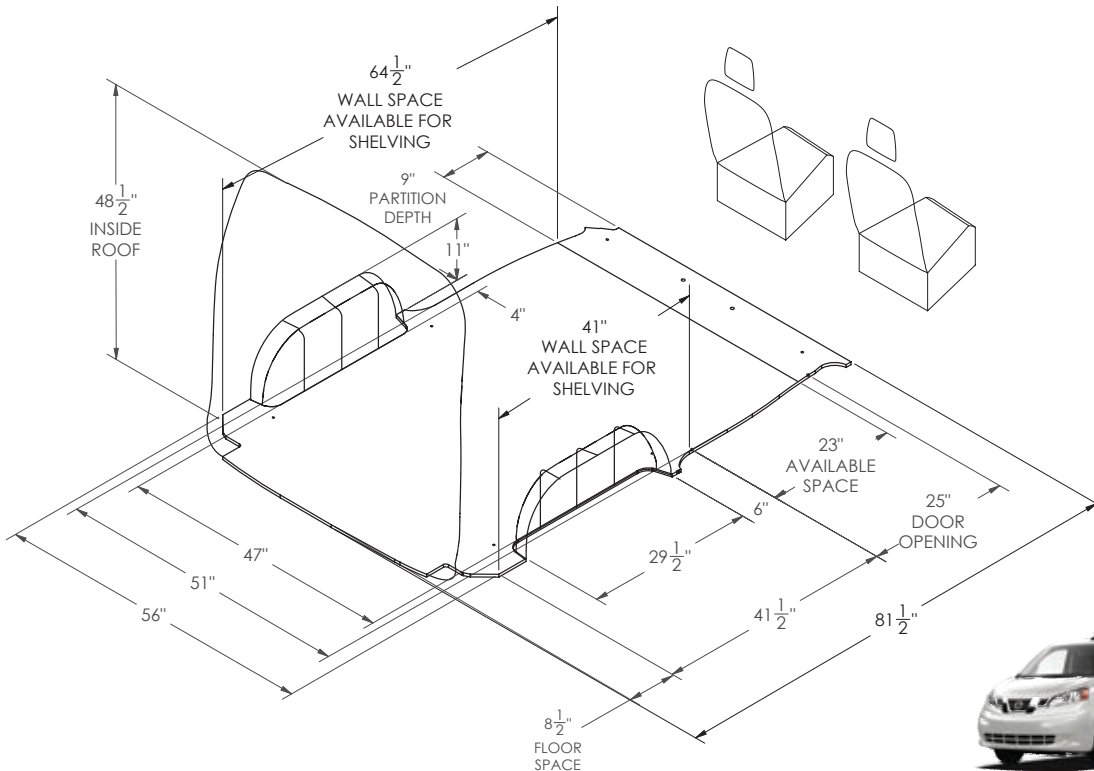

NISSAN NV200

Regular 115" Wheelbase

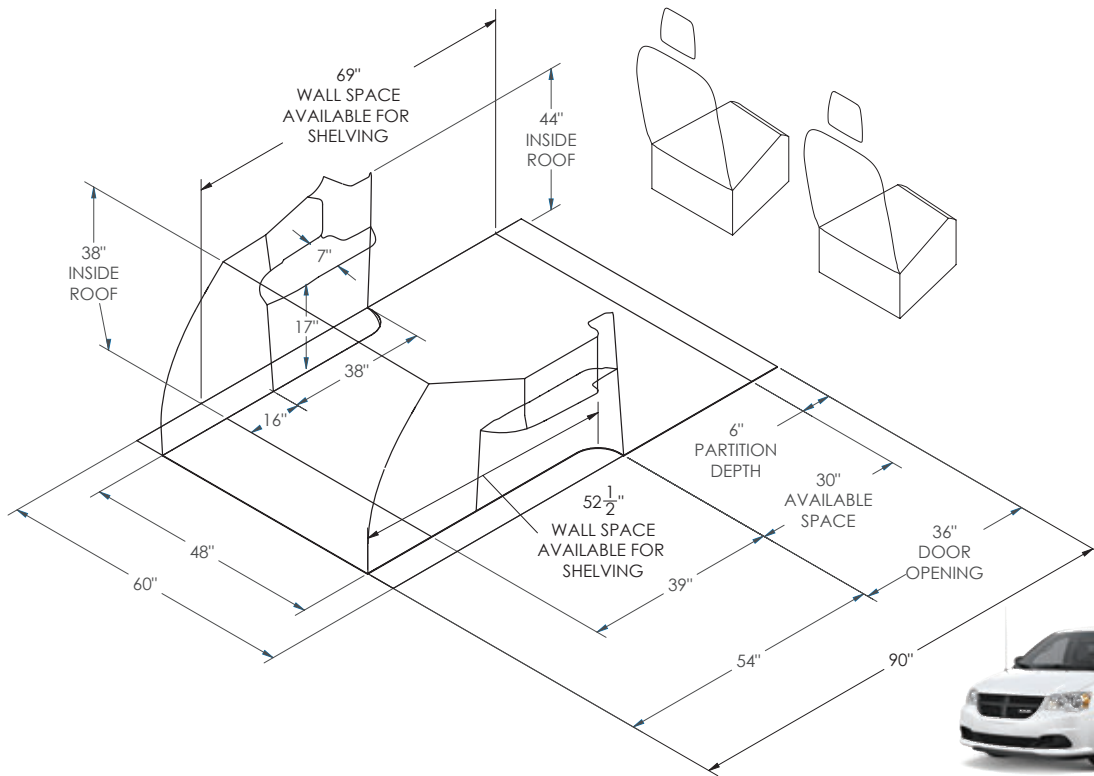

RAM C/V

Regular 121" Wheelbase

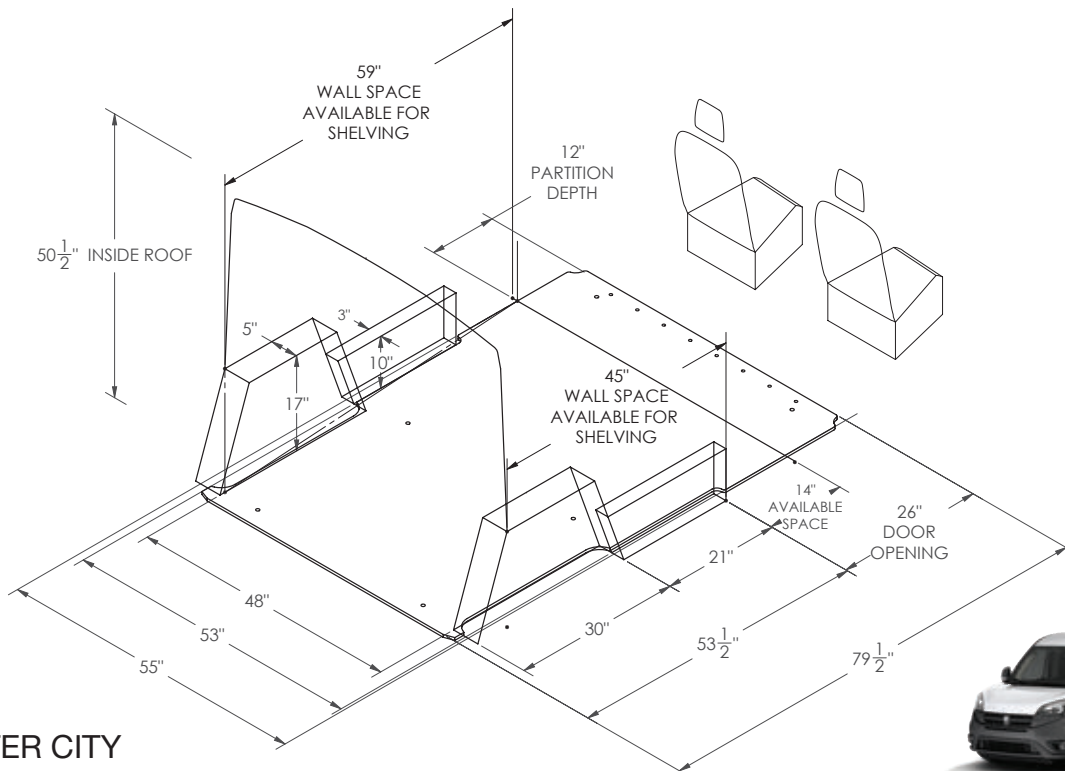

RAM PROMASTER CITY

Standard 122" Wheelbase

LAYOUT GUIDES

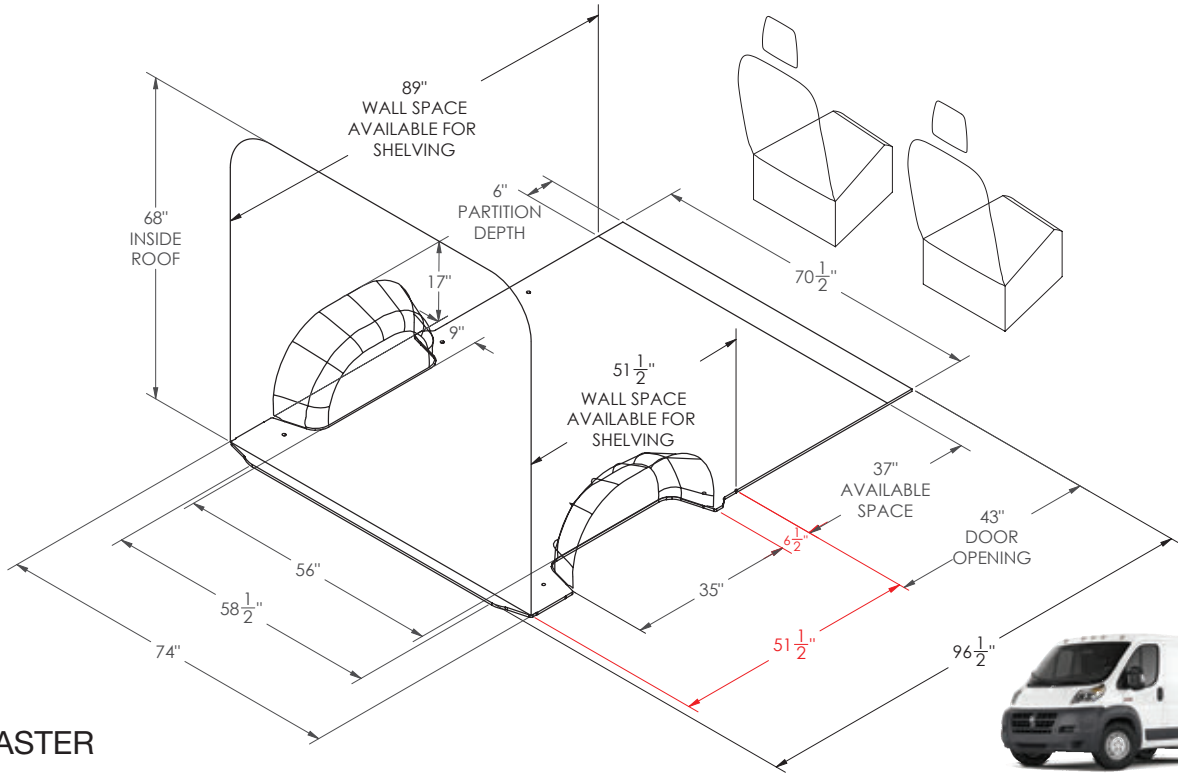

RAM PROMASTER

Short 118" Wheelbase

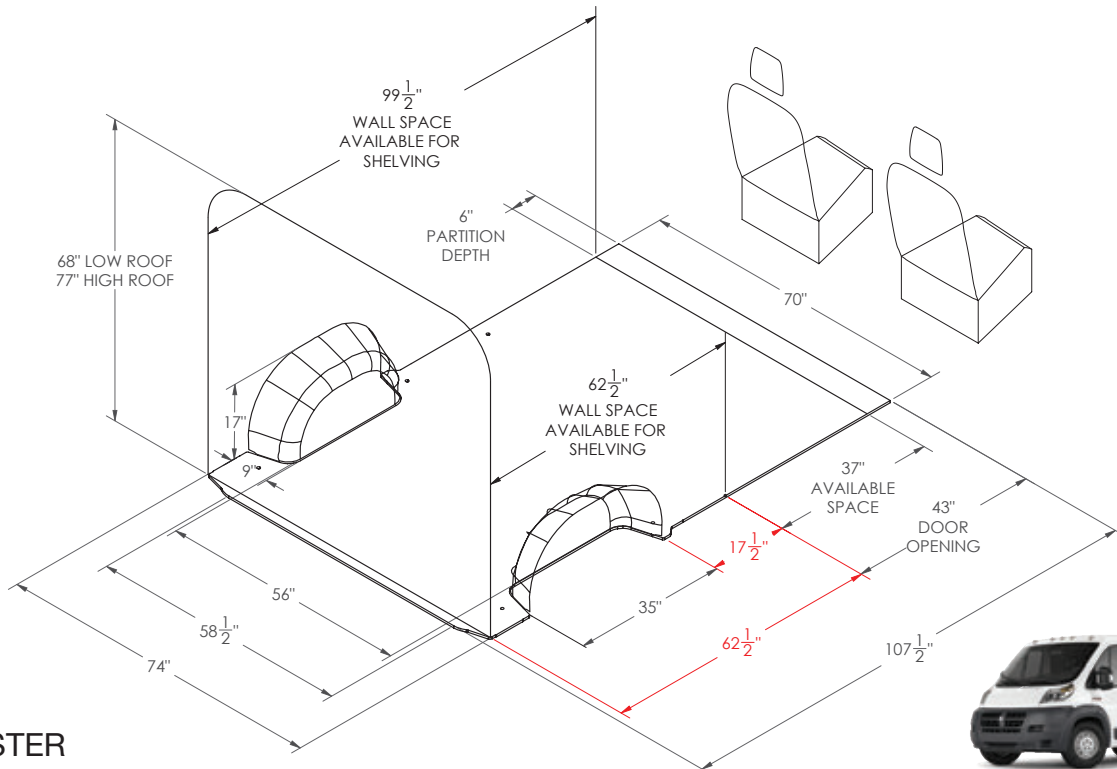

RAM PROMASTER

Medium 136" Wheelbase

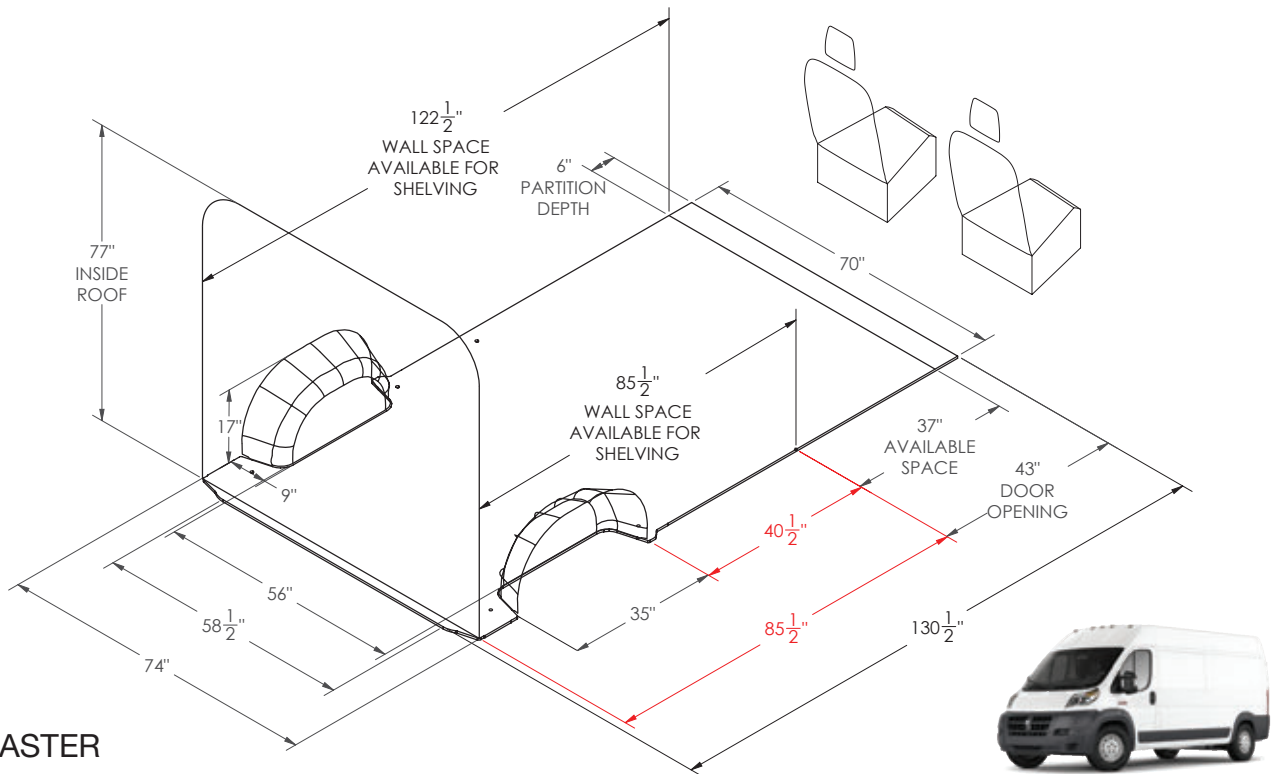

**RAM
PROMASTER**
Long 159" Wheelbase

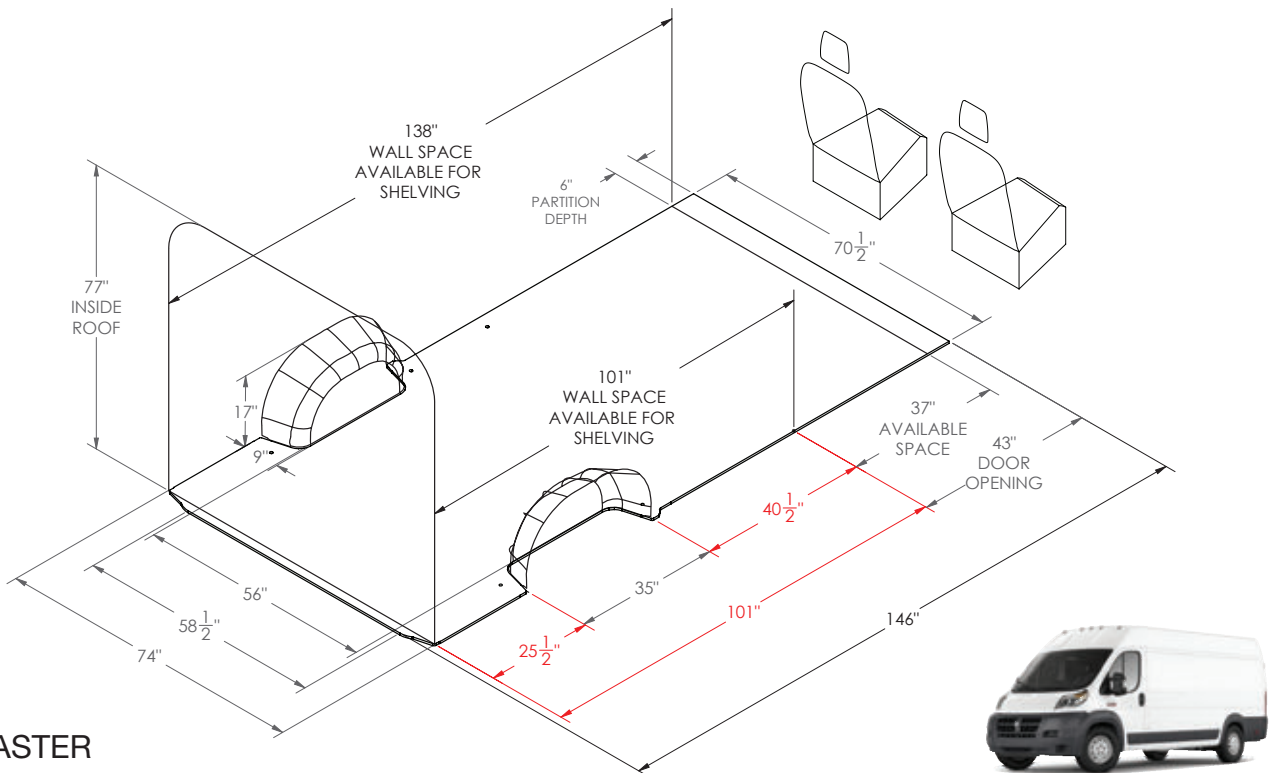

**RAM
PROMASTER**
Extended 159" Wheelbase





FLOORS

Impact and puncture resistant floors preserve the cargo van interior

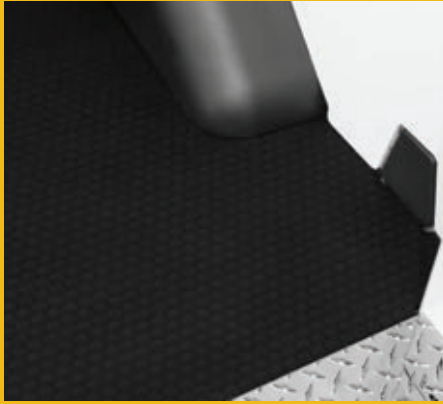

PROTECTION

Rigid floor covering protects cargo van floors from impact damage and scratches.

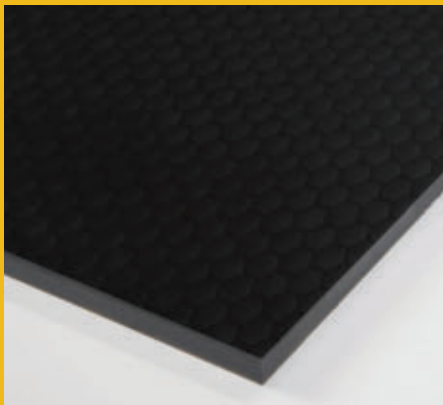

SAFETY

Anti-slip floors also minimize the chances of slipping and reduce shifting of cargo.



EFFICIENCY

Durable floors provide technicians with a professional work surface that is easy to clean.

FLOORS

You may be wondering why our BUYER'S GUIDE is missing a Floor section. Not to worry, as we are actually working on some brand new products and increased selection to be launched later this year!

Check our website for further details and to keep up with what we are doing!

- > Anti-slip surface
- > Easy to install with integrated mounting tracks
- > Compatible with Ranger Design's shelving packages
- > Super tough
- > Include sills
- > No thermal expansion

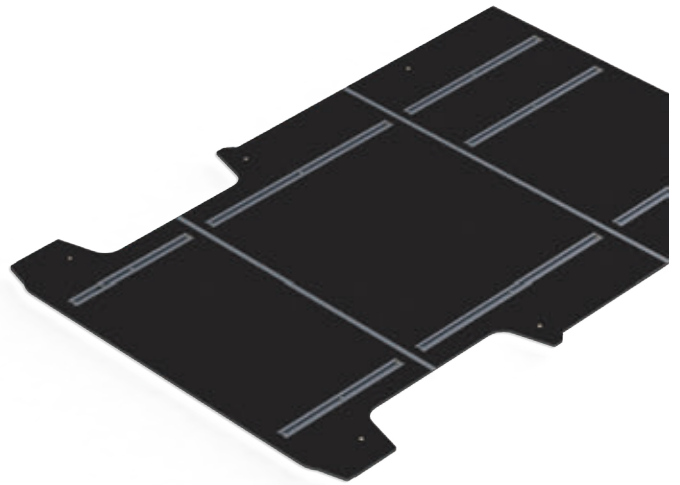

RANGERTM
DESIGN



SAFETY PARTITIONS

Crash tested safety partitions protect the most important asset: you



SAFE

Designed for maximum impact resistance. Proven by impact testing.



EFFICIENT

1. Contoured to maintain seat travel and ensure driver comfort.
2. Contoured to capitalize on cargo area floor space.



QUIET

Thickness of material cancels vibrations.

SAFETY PARTITIONS

CHEVROLET

CITY EXPRESS	P. 28
EXPRESS	P. 29

FORD

E-SERIES	P. 30
TRANSIT	P. 30
TRANSIT CONNECT	P. 34

GMC

SAVANA	P. 36
--------------	-------

MERCEDES-BENZ

METRIS	P. 37
SPRINTER	P. 37

NISSAN

NV	P. 41
NV200	P. 43

RAM

C/V	P. 44
PROMASTER	P. 45
PROMASTER CITY	P. 46

Ranger safety partitions provide a solid and secure barrier between the occupants of the van and the cargo.

Built from heavy gauge steel, aluminum or thermoformed ABS and polycarbonate, these partitions are designed for maximum impact resistance and uphold a standard of safety set only by Ranger products.











Ranger partitions also provide a more comfortable environment for the driver by giving more seat travel and by not rattling as the vehicle drives down the road.

Application Guide



Type	Material	Chevrolet City Express Standard Roof	Chevrolet Express Standard Roof	Ford E-Series Standard Roof	Ford Transit Low Roof	Ford Transit Medium Roof	Ford Transit High Roof	Ford Transit Connect Standard Roof
Contoured Safety Partition	Aluminum	3010-NS P. 28	3010-GS P. 29	–	3010-FTL P. 30	3010-FTM P. 31	3010-FTH P. 30	3010-TC P. 34
Contoured Safety Partition	Composite	–	–	–	–	–	–	–
Contoured Safety Partition	Steel	C12-W P. 28	C12-H P. 29	–	C12-FTL P. 32	–	–	C12-E P. 35
Contoured Safety Partition with Perforated Window	Steel	C10-W P. 28	C10-H P. 29	C10-B P. 30	C10-FTL P. 32	–	–	C10-E P. 35
Contoured Safety Partition with Tempered Glass Window	Aluminum	3020-NS P. 28	3020-GS P. 29	–	3020-FTL P. 31	3020-FTM P. 31	3020-FTH P. 31	3020-TC P. 34
Max View Contoured Safety Partition	Composite	–	–	–	3320-FTL P. 32	–	–	3320-TC P. 35
Mid Position Straight Safety Partition	Aluminum	–	–	–	–	–	–	–
Mid Position Straight Safety Partition with Tempered Glass Window	Aluminum	–	–	–	–	–	–	–
Single Side Straight Partition	Aluminum	–	–	–	–	–	–	–
Straight Partition with Perforated Window, No Access	Steel	–	–	–	C20-FTL P. 33	C20-FTM P. 33	C20-FTH P. 32	–
Straight Partition with Perforated Window, Swing Door	Steel	–	C30-GS P. 29	–	C30-FTL P. 34	C30-FTM P. 34	C30-FTH P. 34	–
Straight Partition with Tempered Glass Window, Sliding Door	Aluminum	–	–	–	–	3068-FTM P. 32	3068-FTH P. 32	–
Straight Walk Through Partition	Aluminum	–	–	–	–	–	–	–
Straight Walk Through Partition	Steel	–	–	–	C24-FTL P. 33	C24-FTM P. 33	C24-FTH P. 33	–
Wire Mesh Partition	Steel	C13-W P. 28	–	–	–	–	–	C13-E P. 35

SAFETY PARTITIONS

										
GMC Savana Standard Roof	Mercedes-Benz Metris Standard Roof	Mercedes-Benz Sprinter Low Roof	Mercedes-Benz Sprinter High Roof	Nissan NV Low Roof	Nissan NV High Roof	Nissan NV200 Standard Roof	Ram C/V Standard Roof	Ram ProMaster Standard Roof	Ram ProMaster High Roof	Ram ProMaster City Standard Roof
3010-GS P. 36	-	3010-DL P. 38	3010-DH P. 37	3010-NL P. 41	3010-NH P. 41	3010-NS P. 43	-	3010-RP P. 45	3010-RP P. 45	3010-PC P. 46
-	-	-	-	-	-	-	-	-	-	3310-PC P. 47
C12-H P. 36	-	-	-	-	-	C12-W P. 44	-	-	-	C12-PC P. 47
C10-H P. 36	C10-MM P. 37	-	-	-	-	C10-W P. 44	C10-Q P. 44	-	-	C10-PC P. 47
3020-GS P. 36	-	3020-DL P. 38	3020-DH P. 38	3020-NL P. 42	3020-NH P. 42	3020-NS P. 43	-	3020-RP P. 45	3020-RP P. 45	3020-PC P. 47
-	3320-MM P. 37	-	-	-	-	-	-	-	-	3320-PC P. 47
-	-	-	3015-DH P. 38	-	-	-	-	-	-	-
-	-	-	3025-DH P. 38	-	-	-	-	-	-	-
-	-	3060-DL P. 39	3060-DH P. 38	-	-	-	-	-	-	-
-	-	C20-DL P. 40	C20-DH P. 40	C20-NL P. 42	C20-NH P. 42	-	-	C20-X P. 45	C20-X P. 45	-
C30-GS P. 36	-	C30-DL P. 41	C30-DH P. 41	C30-NL P. 43	C30-NH P. 43	-	-	C30-X P. 46	C30-X P. 46	-
-	-	3068-DL P. 39	3068-DH P. 39	-	-	-	-	3068-RP P. 45	3068-RP P. 45	-
-	-	3064-DL P. 39	3064-DH P. 39	-	-	-	-	-	-	-
-	-	C24-DL P. 41	C24-DH P. 40	C24-NL P. 42	C24-NH P. 43	-	-	C24-X P. 45	C24-X P. 45	-
-	C13-MM P. 37	-	-	-	-	C13-W P. 44	-	-	-	C13-PC P. 47

SAFETY PARTITIONS

PARTITIONS



CHEVROLET CITY EXPRESS



3010-NS
Chevrolet City Express
Contoured Safety Partition

Aluminum

Standard Roof

42 lbs

1 hr

Yes

3.3"



3020-NS
Chevrolet City Express
Contoured Safety Partition with
Tempered Glass Window

Aluminum

Standard Roof

49 lbs

1 hr

Yes

3.3"



C10-W
Chevrolet City Express
Contoured Safety Partition
with Perforated Window

Steel

Standard Roof

53 lbs

1 hr

Yes

2.94"



C12-W
Chevrolet City Express
Contoured Safety Partition

Steel

Standard Roof

53 lbs

1 hr

Yes

2.94"

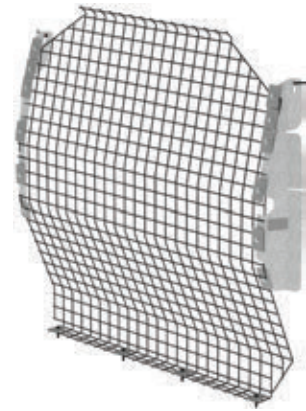

C13-W
Chevrolet City Express
Wire Mesh Partition

Steel

Standard Roof

25 lbs

0.7 hr

Yes

3.45"



CHEVROLET EXPRESS



3010-GS
Chevrolet Express
Contoured Safety Partition

Aluminum

Standard Roof
42 lbs
1 hr
Yes
5.56"



3020-GS
Chevrolet Express
Contoured Safety Partition with Tempered Glass Window

Aluminum

Standard Roof
49 lbs
1 hr
No
5.56"

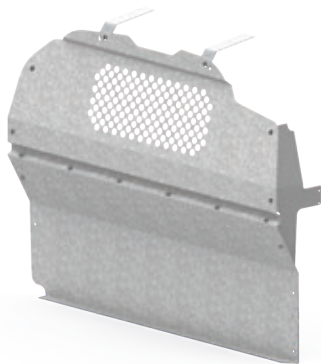

C10-H
Chevrolet Express
Contoured Safety Partition with Perforated Window

Steel

Standard Roof
53 lbs
1 hr
Yes
5.56"

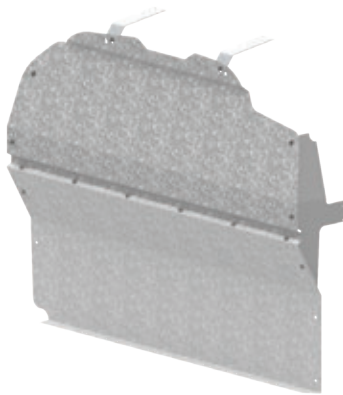

C12-H
Chevrolet Express
Contoured Safety Partition

Steel

Standard Roof
53 lbs
1 hr
No
5.56"

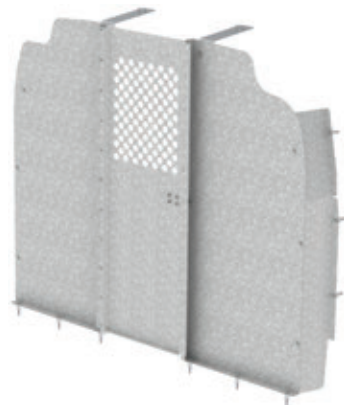

C30-GS
Chevrolet Express
Straight Partition with Perforated Window, Swing Door

Steel

Standard Roof
61 lbs
1 hr
No

SAFETY PARTITIONS

PARTITIONS



FORD E-SERIES

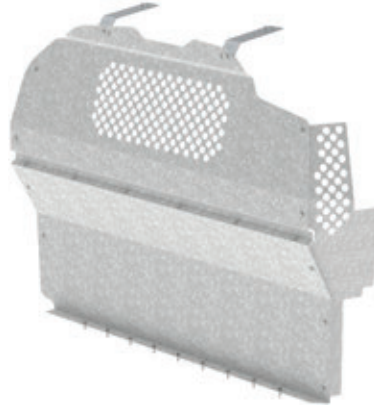

C10-B
Ford E-Series
Contoured Safety Partition
with Perforated Window

Steel

Standard Roof

53 lbs

1 hr

No

12.5"



3010-FTH Contoured Safety
Partition for Ford Transit



FORD TRANSIT



3010-FTH
Ford Transit
Contoured Safety Partition

Aluminum

High Roof

57 lbs

1 hr

Yes

8.32"



3010-FTL
Ford Transit
Contoured Safety Partition

Aluminum

Low Roof

46 lbs

1 hr

Yes

7.16"



3010-FTM
 Ford Transit
 Contoured Safety Partition

Aluminum	
Medium Roof	
52 lbs	
1 hr	
Yes	
8.32"	



3020-FTH
 Ford Transit
 Contoured Safety Partition with
 Tempered Glass Window

Aluminum	
High Roof	
58 lbs	
1 hr	
Yes	
8.32"	



3020-FTL
 Ford Transit
 Contoured Safety Partition with
 Tempered Glass Window

Aluminum	
Low Roof	
48 lbs	
1 hr	
Yes	
7.16"	



3020-FTM
 Ford Transit
 Contoured Safety Partition with
 Tempered Glass Window

Aluminum	
Medium Roof	
52 lbs	
1 hr	
Yes	
8.32"	

SETBACK FROM B PILLAR

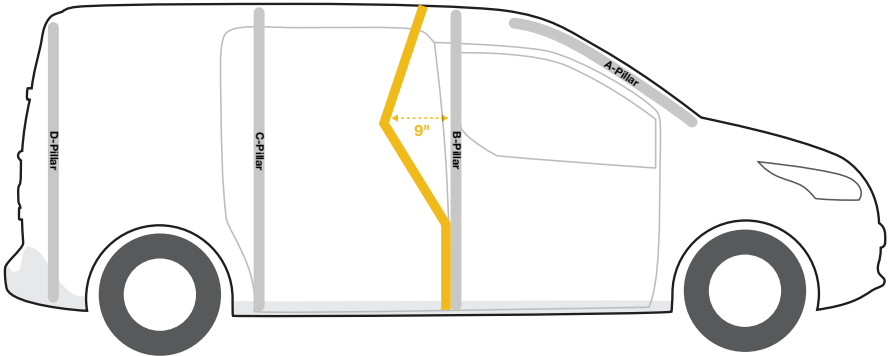

SAFETY PARTITIONS

PARTITIONS



3068-FTH

Ford Transit
Straight Partition with Tempered Glass Window, Sliding Door

Aluminum

High Roof
77 lbs
1.5 hrs
Yes
6.29"



3068-FTM

Ford Transit
Straight Partition with Tempered Glass Window, Sliding Door

Aluminum

Medium Roof
74 lbs
1.5 hrs
Yes
6.29"



3320-FTL

Ford Transit
Max View Contoured Safety Partition

Composite

Low Roof
50 lbs
1 hr
No
8.13"



C10-FTL

Ford Transit
Contoured Safety Partition with Perforated Window

Steel

Low Roof
66 lbs
1 hr
Yes
7.11"



C12-FTL

Ford Transit
Contoured Safety Partition

Steel

Low Roof
64 lbs
1 hr
Yes
7.11"



C20-FTH

Ford Transit
Straight Partition with Perforated Window, No Access

Steel

High Roof
84 lbs
1 hr
Yes
4.76"



C20-FTL

Ford Transit
Straight Partition with Perforated Window, No Access

Steel	
Low Roof	
64 lbs	
1 hr	
Yes	
3.76"	



C20-FTM

Ford Transit
Straight Partition with Perforated Window, No Access

Steel	
Medium Roof	
77 lbs	
1 hr	
Yes	
4.76"	



C24-FTH

Ford Transit
Straight Walk Through Partition

Steel	
High Roof	
65 lbs	
1.2 hrs	
Yes	
4.76"	



C24-FTL

Ford Transit
Straight Walk Through Partition

Steel	
Low Roof	
49 lbs	
1.2 hrs	
Yes	
3.76"	



C24-FTM

Ford Transit
Straight Walk Through Partition

Steel	
Medium Roof	
58 lbs	
1.2 hrs	
Yes	
4.76"	



3010-FTL Contoured Safety Partition for the Ford Transit

SAFETY PARTITIONS

PARTITIONS



C30-FTH

Ford Transit
Straight Partition with Perforated Window, Swing Door

Steel

High Roof
86 lbs
1.5 hrs
Yes
4.96"



C30-FTL

Ford Transit
Straight Partition with Perforated Window, Swing Door

Steel

Low Roof
65 lbs
1.5 hrs
Yes
3.87"



C30-FTM

Ford Transit
Straight Partition with Perforated Window, Swing Door

Steel

Medium Roof
79 lbs
1.5 hrs
Yes
4.96"



FORD TRANSIT CONNECT



3010-TC

Ford Transit Connect
Contoured Safety Partition

Aluminum

Standard Roof
42 lbs
1 hr
Yes
9.04"

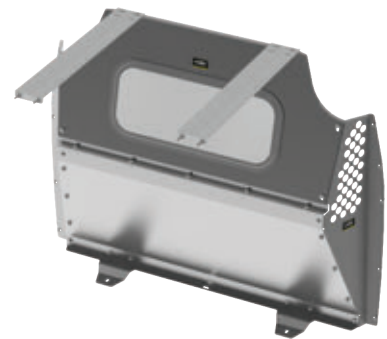

3020-TC

Ford Transit Connect
Contoured Safety Partition with Tempered Glass Window

Aluminum

Standard Roof
42 lbs
1 hr
Yes
9.04"



3320-TC

Ford Transit Connect
Max View Contoured Safety Partition

Composite

Standard Roof
36 lbs
1 hr
No
8.4"

3320-TC Max View Contoured Safety Partition for the Ford Transit Connect Shown here with an Optional **6070** Hook

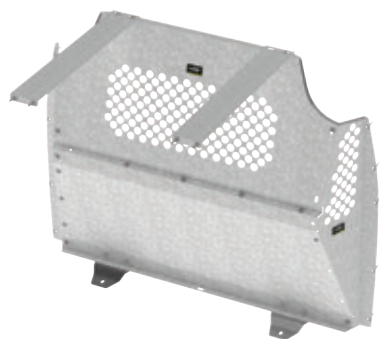

C10-E

Ford Transit Connect
Contoured Safety Partition
with Perforated Window

Steel

Standard Roof
53 lbs
1 hr
Yes
8.99"



C12-E

Ford Transit Connect
Contoured Safety Partition

Steel

Standard Roof
53 lbs
1 hr
Yes
8.99"

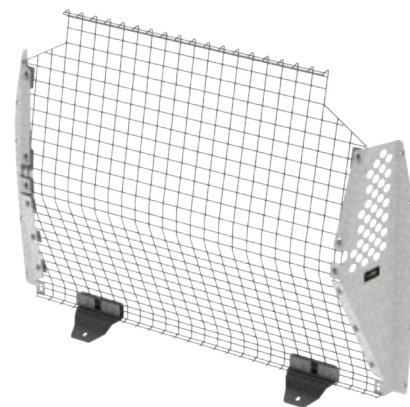

C13-E

Ford Transit Connect
Wire Mesh Partition

Steel

Standard Roof
27 lbs
0.7 hr
Yes
8.94"

SAFETY PARTITIONS

PARTITIONS



GMC
SAVANA



3010-GS
GMC Savana
Contoured Safety Partition

Aluminum

Standard Roof
42 lbs
1 hr
Yes
5.56"

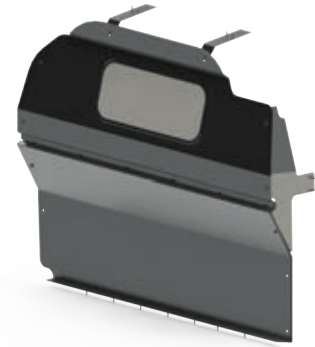

3020-GS
GMC Savana
Contoured Safety Partition with
Tempered Glass Window

Aluminum

Standard Roof
49 lbs
1 hr
No
5.56"

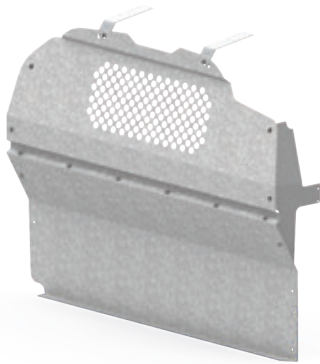

C10-H
GMC Savana
Contoured Safety Partition
with Perforated Window

Steel

Standard Roof
53 lbs
1 hr
Yes
5.56"

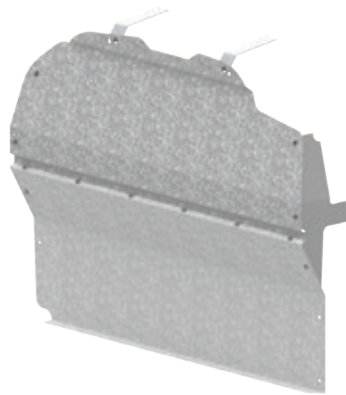

C12-H
GMC Savana
Contoured Safety Partition

Steel

Standard Roof
53 lbs
1 hr
No
5.56"

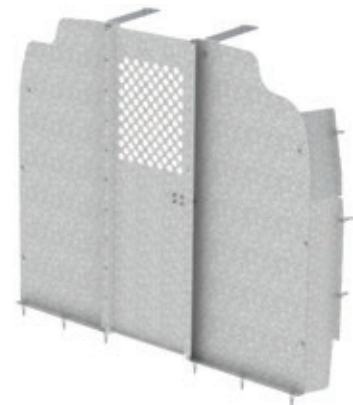

C30-GS
GMC Savana
Straight Partition with Perforated
Window, Swing Door

Steel

Standard Roof
61 lbs
1 hr
No
6.5"



MERCEDES-BENZ METRIS

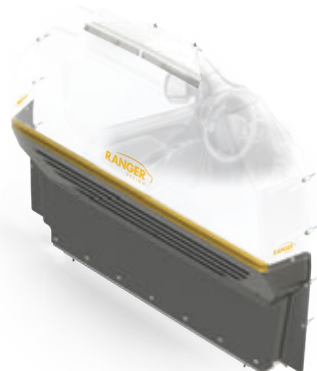

3320-MM

Mercedes-Benz Metris
Max View Contoured Safety Partition

Composite

Standard Roof

48 lbs

1.2 hrs

No

9"

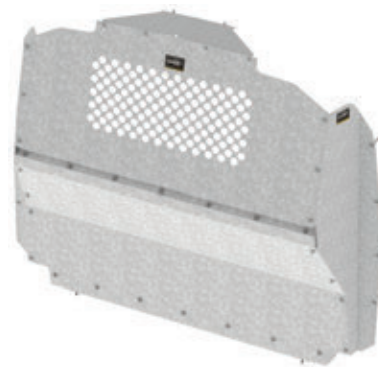

C10-MM

Mercedes-Benz Metris
Contoured Safety Partition
with Perforated Window

Steel

Standard Roof

62 lbs

1 hr

Yes

11"

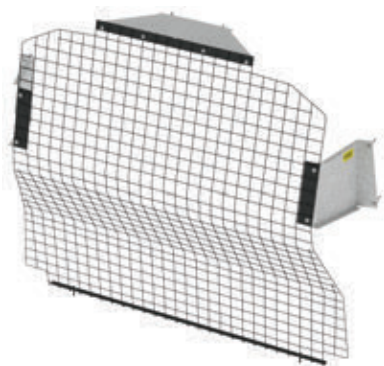

C13-MM

Mercedes-Benz Metris
Wire Mesh Partition

Steel

Standard Roof

37 lbs

1.2 hrs

No

11"



MERCEDES-BENZ SPRINTER

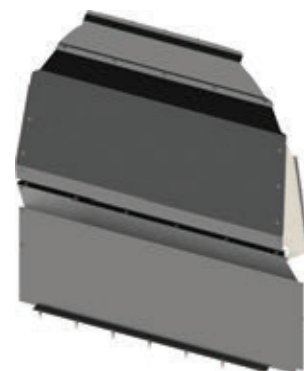

3010-DH

Mercedes-Benz Sprinter
Contoured Safety Partition

Aluminum

High Roof

59 lbs

1.2 hrs

No

5.5"

SAFETY PARTITIONS

PARTITIONS

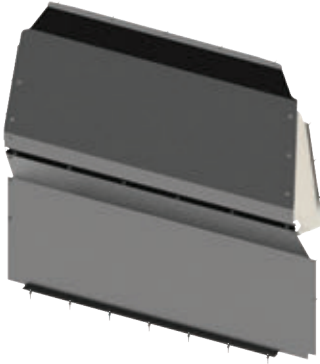

3010-DL

Mercedes-Benz Sprinter
Contoured Safety Partition

Aluminum

Low Roof

57 lbs

1.2 hrs

No

5.5"



3015-DH

Mercedes-Benz Sprinter
Mid Position Straight Safety Partition

Aluminum

High Roof

59 lbs

1.2 hrs

No

2.5"



3020-DH

Mercedes-Benz Sprinter
Contoured Safety Partition with
Tempered Glass Window

Aluminum

High Roof

66 lbs

1.2 hrs

No

5.5"



3020-DL

Mercedes-Benz Sprinter
Contoured Safety Partition with
Tempered Glass Window

Aluminum

Low Roof

64 lbs

1.2 hrs

No

5.5"



3025-DH

Mercedes-Benz Sprinter
Mid Position Straight Safety Partition
with Tempered Glass Window

Aluminum

High Roof

66 lbs

1.2 hrs

No

2.5"



3060-DH

Mercedes-Benz Sprinter
Single Side Straight Partition

Aluminum

High Roof

30 lbs

0.7 hr

No

5"



3060-DL

Mercedes-Benz Sprinter
Single Side Straight Partition

Aluminum

Low Roof

29 lbs

0.7 hr

No

5"



3064-DH

Mercedes-Benz Sprinter
Straight Walk Through Partition

Aluminum

High Roof

42 lbs

1 hr

No

5"



3064-DL

Mercedes-Benz Sprinter
Straight Walk Through Partition

Aluminum

Low Roof

40 lbs

1 hr

No

6.5"



3068-DH

Mercedes-Benz Sprinter
Straight Partition with Tempered
Glass Window, Sliding Door

Aluminum

High Roof

80 lbs

1.5 hrs

Yes

8"



3068-DL

Mercedes-Benz Sprinter
Straight Partition with Tempered
Glass Window, Sliding Door

Aluminum

Low Roof

78 lbs

1.5 hrs

No

7.25"



3068 DH Straight Partition with
Tempered Glass Window, Sliding
Door for Mercedes-Benz Sprinter

SAFETY PARTITIONS

PARTITIONS



C20-DH

Mercedes-Benz Sprinter
Straight Partition with Perforated Window, No Access

Steel

High Roof

89 lbs

1 hr

Yes

7.5"



C20-DL

Mercedes-Benz Sprinter
Straight Partition with Perforated Window, No Access

Steel

Low Roof

80 lbs

1 hr

Yes

7.5"



C24-DH

Mercedes-Benz Sprinter
Straight Walk Through Partition

Steel

High Roof

66 lbs

1 hr

No

7.5"

CONTOURED SAFETY PARTITIONS

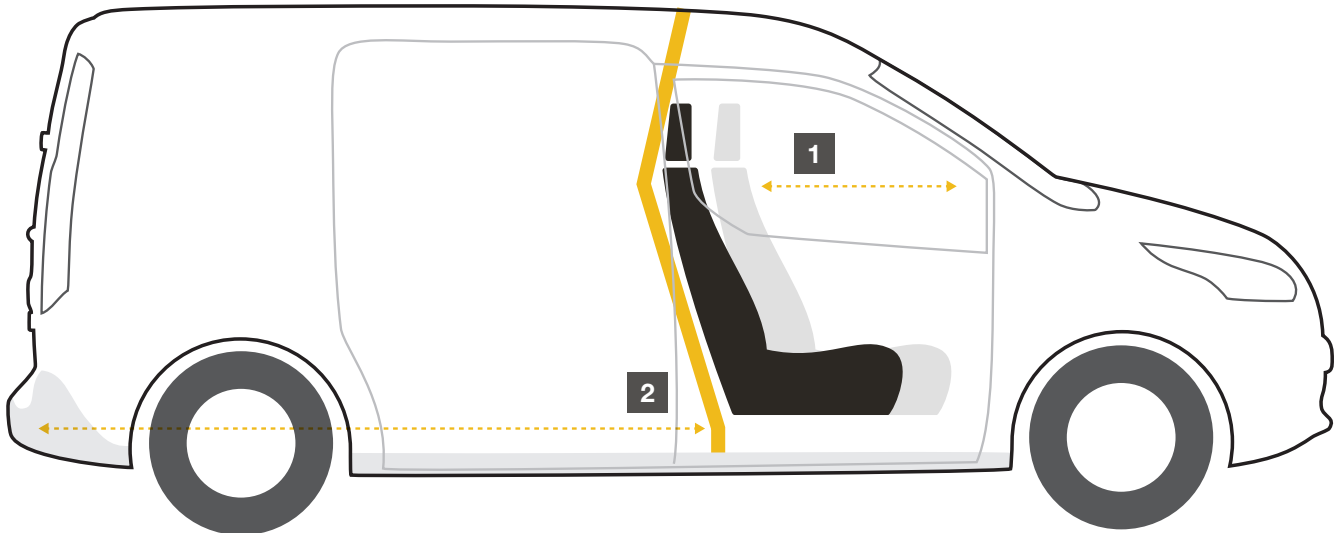

1. Contoured to maintain seat travel and ensure driver comfort.
2. Contoured to capitalize on cargo area floor space.



C24-DL
Mercedes-Benz Sprinter
Straight Walk Through Partition

Steel

Low Roof
61 lbs
1 hr
No
7.5"



C30-DH
Mercedes-Benz Sprinter
Straight Partition with Perforated Window, Swing Door

Steel

High Roof
92 lbs
1 hr
No
8"



C30-DL
Mercedes-Benz Sprinter
Straight Partition with Perforated Window, Swing Door

Steel

Low Roof
83 lbs
1 hr
No
8"



NISSAN
NV



3010-NH
Nissan NV
Contoured Safety Partition

Aluminum

High Roof
59 lbs
1.2 hrs
Yes
5.78"



3010-NL
Nissan NV
Contoured Safety Partition

Aluminum

Low Roof
42 lbs
1 hr
Yes
5.78"

SAFETY PARTITIONS

PARTITIONS



3010-NL Contoured Safety Partition for Nissan NV



3020-NH

Nissan NV
Contoured Safety Partition with Tempered Glass Window

Aluminum

High Roof

59 lbs

1.2 hrs

No

5.78"



3020-NL

Nissan NV
Contoured Safety Partition with Tempered Glass Window

Aluminum

Low Roof

42 lbs

1 hr

No

5.78"



C20-NL

Nissan NV
Straight Partition with Perforated Window, No Access

Steel

Low Roof

58 lbs

1 hr

No

4"

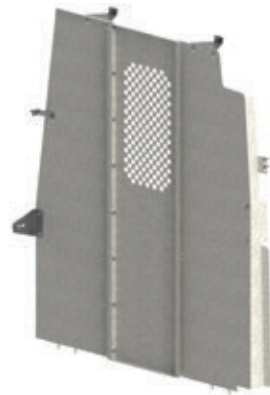

C20-NH

Nissan NV
Straight Partition with Perforated Window, No Access

Steel

High Roof

80 lbs

1.5 hrs

No

5.5"



C24-NL

Nissan NV
Straight Walk Through Partition

Steel

Low Roof

43.5 lbs

1 hr

No



C24-NH
Nissan NV
Straight Walk Through Partition

Steel	
High Roof	
57 lbs	
1 hr	
No	
4"	



C30-NH
Nissan NV
Straight Partition with Perforated Window, Swing Door

Steel	
High Roof	
83 lbs	
1 hr	
No	



C30-NL
Nissan NV
Straight Partition with Perforated Window, Swing Door

Steel	
Low Roof	
61 lbs	
1 hr	
No	



NISSAN
NV200



3010-NS
Nissan NV200
Contoured Safety Partition

Aluminum	
Standard Roof	
42 lbs	
1 hr	
Yes	
3.3"	



3020-NS
Nissan NV200
Contoured Safety Partition with Tempered Glass Window

Aluminum	
Standard Roof	
49 lbs	
1 hr	
Yes	
3.3"	

SAFETY PARTITIONS

PARTITIONS



C10-W

Nissan NV200
Contoured Safety Partition
with Perforated Window

Steel

Standard Roof
53 lbs
1 hr
Yes
2.94"



C12-W

Nissan NV200
Contoured Safety Partition

Steel

Standard Roof
53 lbs
1 hr
Yes
2.94"



3010-RP Contoured Safety
Partition for Ram Promaster

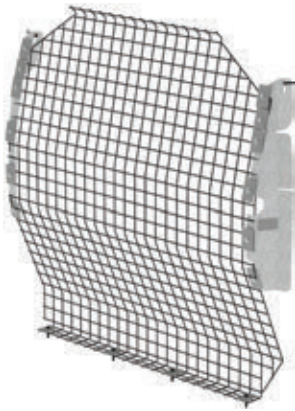

C13-W

Nissan NV200
Wire Mesh Partition

Steel

Standard Roof
25 lbs
0.7 hr
Yes
3.45"



RAM
C/V

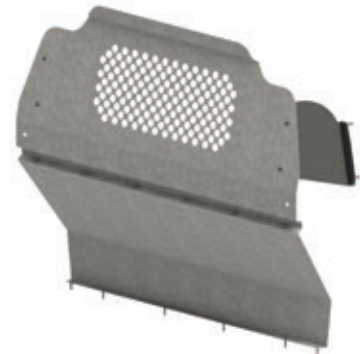

C10-Q

Ram C/V
Contoured Safety Partition
with Perforated Window

Steel

Standard Roof
53 lbs
1 hr
No
11"



RAM PROMASTER



3010-RP
Ram ProMaster
Contoured Safety Partition

Aluminum

Standard / High Roof

59 lbs

1 hr

Yes

6.07"



3020-RP
Ram ProMaster
Contoured Safety Partition with
Tempered Glass Window

Aluminum

Standard / High Roof

59 lbs

1 hr

Yes

6.07"



3068-RP
Ram ProMaster
Straight Partition with Tempered
Glass Window, Sliding Door

Aluminum

Standard / High Roof

76 lbs

1.5 hrs

Yes

6.26"

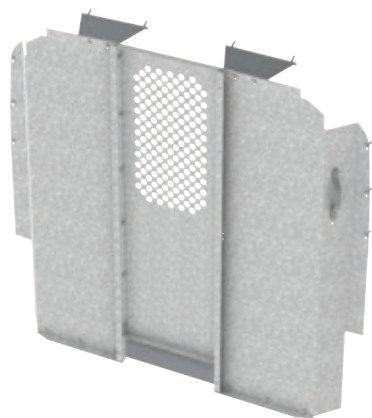

C20-X
Ram ProMaster
Straight Partition with Perforated
Window, No Access

Steel

Standard / High Roof

78 lbs

1 hr

Yes

6.24"



C24-X
Ram ProMaster
Straight Walk Through Partition

Steel

Standard / High Roof

61 lbs

1 hr

Yes

6.24"

SAFETY PARTITIONS

PARTITIONS

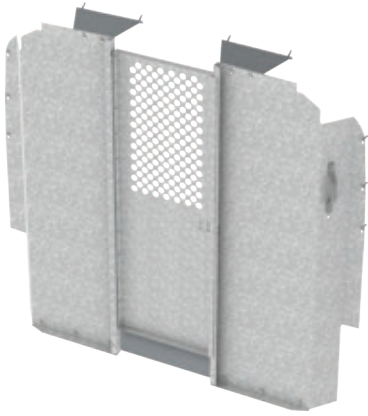

C30-X

Ram ProMaster
Straight Partition with Perforated
Window, Swing Door

Steel

Standard / High Roof

80 lbs

1 hr

Yes

6.24"



RAM
PROMASTER CITY



3010-PC

Ram ProMaster City
Contoured Safety Partition

Aluminum

Standard Roof

39 lbs

1 hr

Yes

8.1"

RANGER DESIGN COMPOSITE PARTITIONS

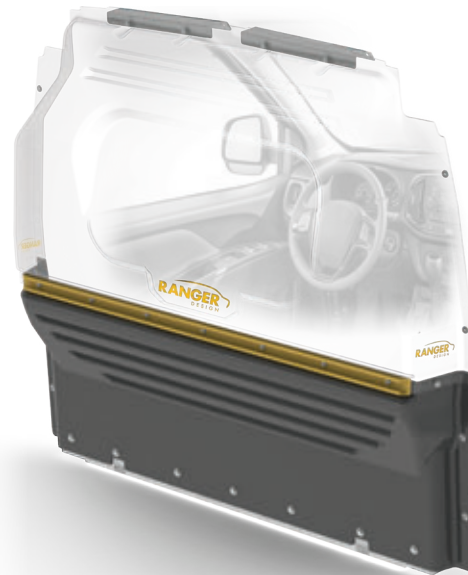

3310-PC Contoured Safety Partition for Ram
Promaster City shown here with Optional Grab Handle **6093**

3320-PC Max View Contoured Safety
Partition for Ram Promaster City



3020-PC

Ram ProMaster City
Contoured Safety Partition with
Tempered Glass Window

Aluminum

Standard Roof

41 lbs

1 hr

Yes

8.1"



3310-PC

Ram ProMaster City
Contoured Safety Partition

Composite

Standard Roof

44 lbs

1 hr

No

7.1"



3320-PC

Ram ProMaster City
Max View Contoured Safety Partition

Composite

Standard Roof

42 lbs

1 hr

No

7.1"

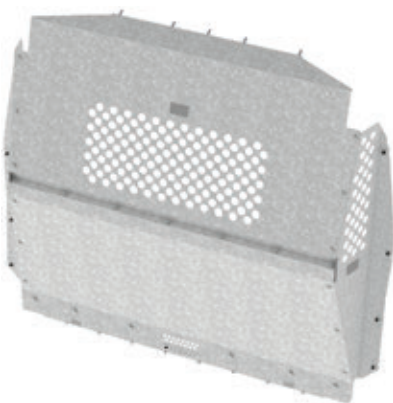

C10-PC

Ram ProMaster City
Contoured Safety Partition
with Perforated Window

Steel

Standard Roof

85 lbs

1 hr

Yes

8.05"

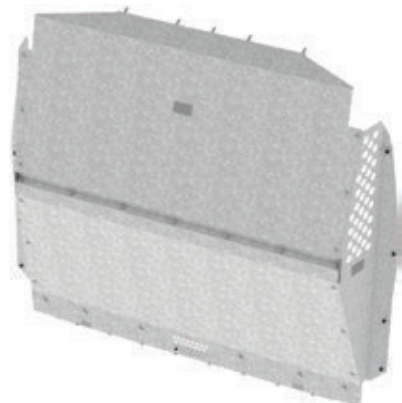

C12-PC

Ram ProMaster City
Contoured Safety Partition

Steel

Standard Roof

86 lbs

1 hr

Yes

8.05"



C13-PC

Ram ProMaster City
Wire Mesh Partition

Steel

Standard Roof

72 lbs

1 hr

Yes

8.33"



TRADE PACKAGES

Pre-engineered packages for a broad range of trades.



CHOICE

A range of Fleetline and Proline packages are available for each vehicle.



TRADE SPECIFIC

Packages are created with the specific trades in mind. Optimized for maximum productivity.



PERFECT FIT

Engineered to optimize space. Layout designed to ensure that all tools are well within reach.

TRADE PACKAGES

BOX TRUCK P. 50

CHEVROLET

CITY EXPRESS P. 57

EXPRESS P. 68

FORD

TRANSIT P. 78

TRANSIT CONNECT P. 97

GMC

SAVANA P. 107

MERCEDES-BENZ

METRIS P. 115

SPRINTER P. 123

NISSAN

NV P. 136

NV200 P. 142

RAM

PROMASTER P. 151

PROMASTER CITY P. 163

Get more out of your work van: Ranger packages are designed specifically with your trade in mind. Our aim is to ensure that your most frequently used tools and equipment are well within reach.

Do you see a way that we can improve our packages? We appreciate your feedback! Contact our customer service team at **1-800-565-5321**.



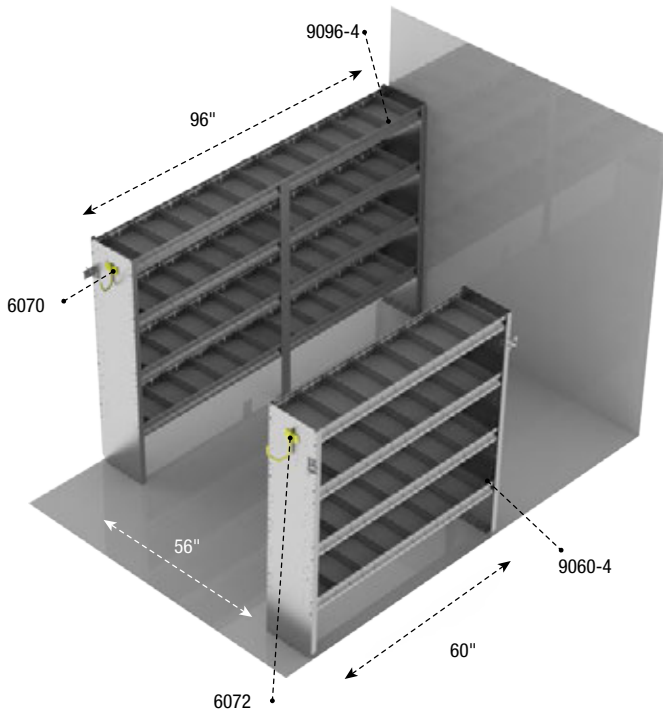

B110

Contractor Package

Aluminum

10+, 14+	198 lbs	2.6 hrs
Standard	No	

Qty	Part #	Description
1	6070	6" Hook, 3" opening, painted
1	6072	8" Swivel Hook, 4" opening, painted
1	9060-4	Square Back Shelving Unit with Dividers
1	9096-4	Square Back Shelving Unit with Dividers

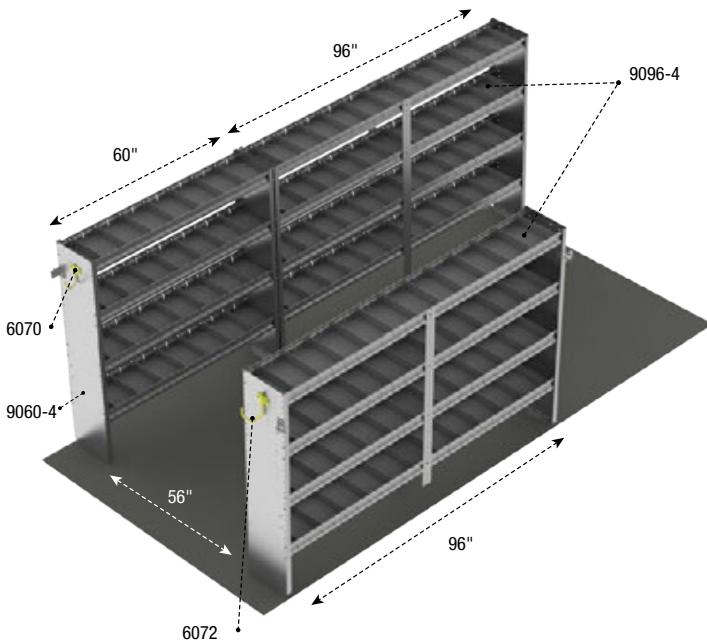

B210

Contractor Package

Aluminum

14+	315 lbs	3.7 hrs
Standard	No	

Qty	Part #	Description
1	6070	6" Hook, 3" opening, painted
1	6072	8" Swivel Hook, 4" opening, painted
1	9060-4	Square Back Shelving Unit with Dividers
2	9096-4	Square Back Shelving Unit with Dividers



BOX TRUCK & TRAILER

PACKAGES

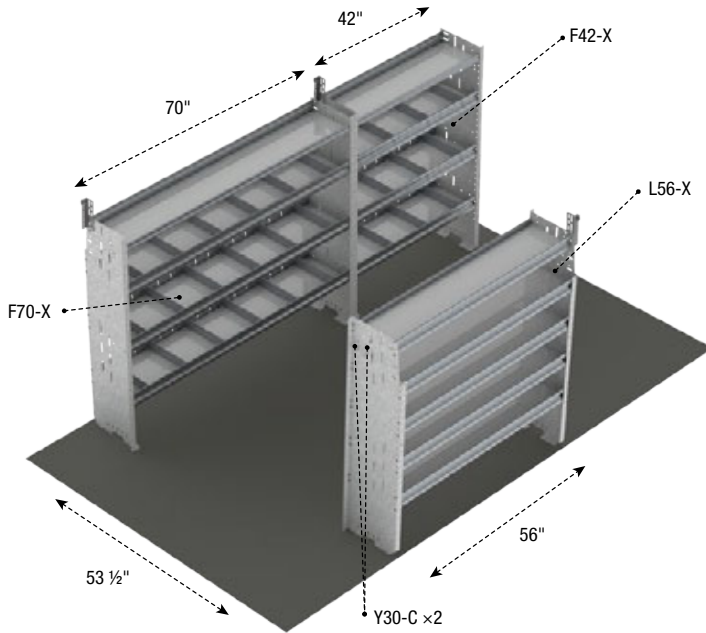

Z10-D

Contractor Package

Steel

10+, 14+	275 lbs	3.4 hrs
Standard	No	

Qty	Part #	Description
1	F42-X	Square Back Shelving Unit with Dividers
1	F70-X	Square Back Shelving Unit with Dividers
1	L56-X	Square Back Shelving Unit
2	Y30-C	Coat Hook, 1" opening, chrome plated

PACKAGES

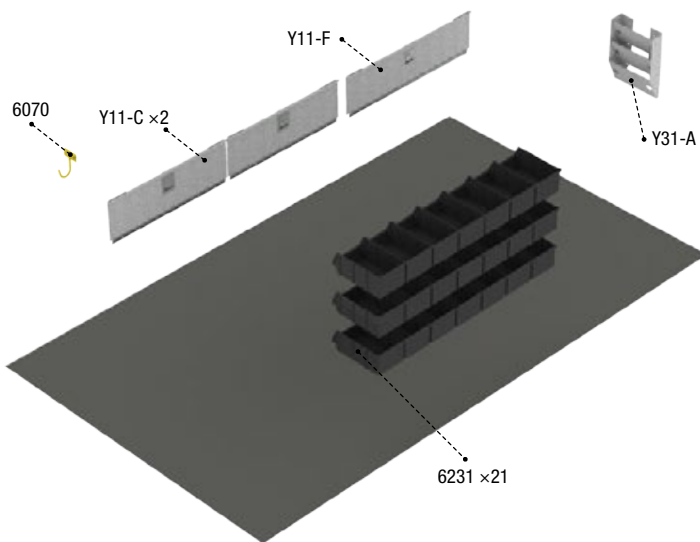

Z30-D

Upgrade Package for 10' Box

Steel

10+, 14+	70 lbs	1.9 hrs
Standard	No	

Qty	Part #	Description
1	6070	6" Hook, 3" opening, painted
21	6231	Large Bin, Graphite
2	Y11-C	Locking door kit
1	Y11-F	Locking door kit
1	Y31-A	Paper Holder, extra deep, 3 slots

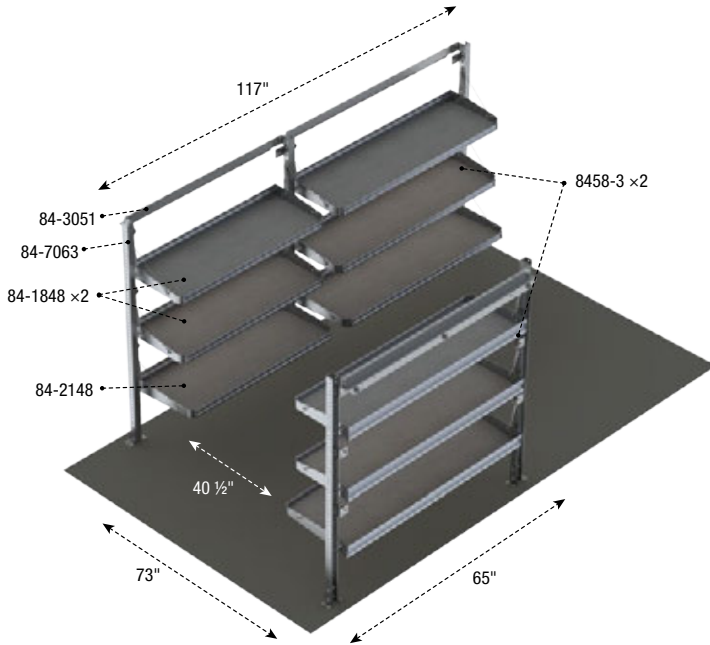

B119

Delivery Package

Aluminum

10+, 14+	233 lbs	4.9 hrs
Standard	No	

Qty	Part #	Description
2	84-1848	Fold-Away Shelf Tray with Gas Shocks and Hardware
1	84-2148	Fold-Away Shelf Tray with Gas Shocks and Hardware
1	84-3051	Mounting Bar Assembly for Fold-Away Shelving
1	84-7063	Post Assembly for Fold-Away Shelving
2	8458-3	Fold-Away Shelving

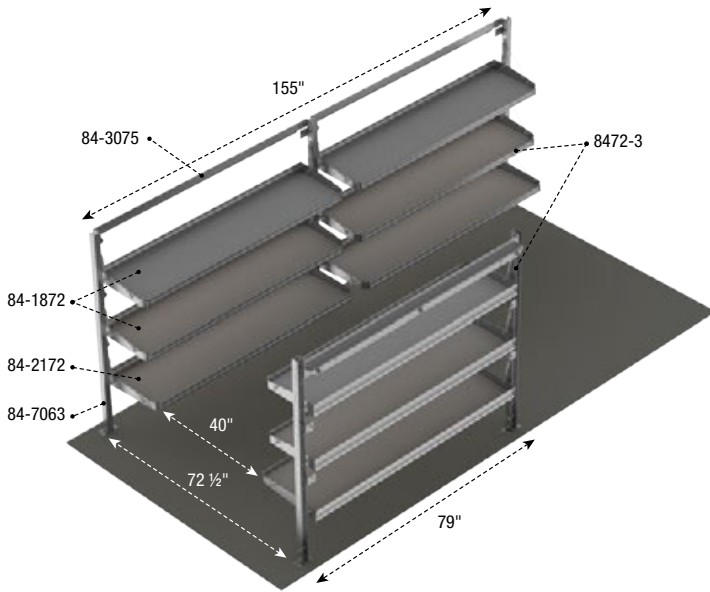

B219

Delivery Package

Aluminum

14+	289 lbs	5.3 hrs
Standard	No	

Qty	Part #	Description
2	84-1872	Fold-Away Shelf Tray with Gas Shocks and Hardware
1	84-2172	Fold-Away Shelf Tray with Gas Shocks and Hardware
1	84-3075	Mounting Bar Assembly for Fold-Away Shelving
1	84-7063	Post Assembly for Fold-Away Shelving
2	8472-3	Fold-Away Shelving



BOX TRUCK & TRAILER

PACKAGES

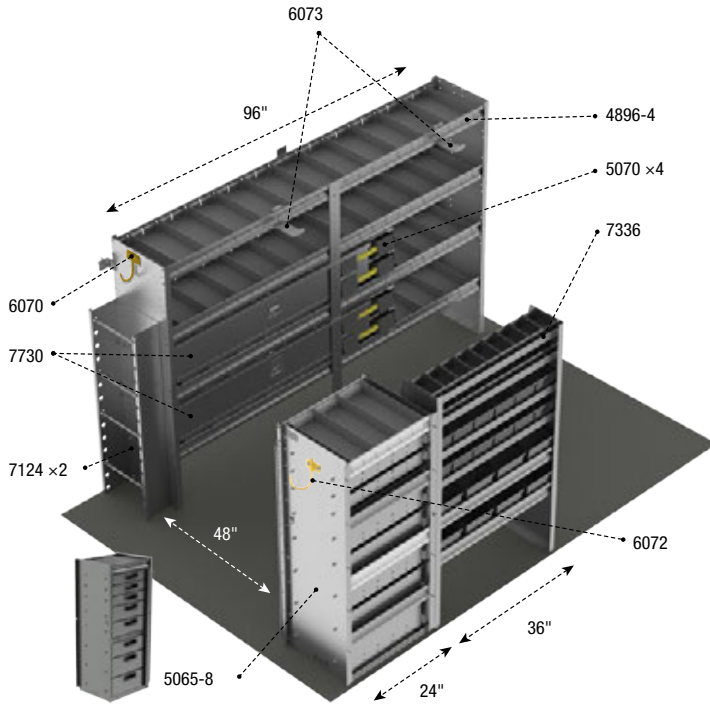

B111

Electrical Package

Aluminum

10+, 14+	407 lbs	6.8 hrs
Standard	No	

Qty	Part #	Description
1	4896-4	Square Back Shelving Unit with Dividers
1	5065-8	8 Drawer cabinet, square back
4	5070	Partskeeper carry case with holder, universal
1	6070	6" Hook, 3" opening, painted
1	6072	8" Swivel Hook, 4" opening, painted
2	6073	Large aluminum movable hook, 6.5" opening
2	7124	Reel Holder with two 5/8" diameter rods
1	7336	Square Back Bin Shelving Unit
2	7730	Locking door kit

PACKAGES

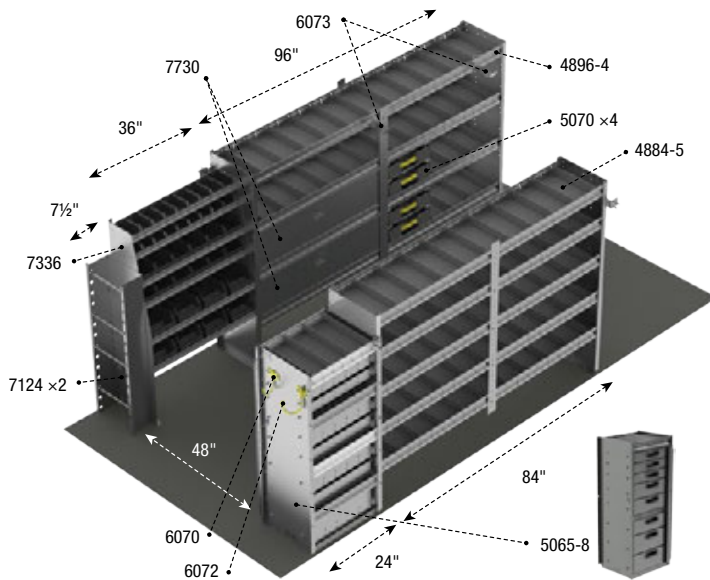

B211

Electrical Package

Aluminum

14+	547 lbs	8 hrs
Standard	No	

Qty	Part #	Description
1	4884-5	Square Back Shelving Unit with Dividers
1	4896-4	Square Back Shelving Unit with Dividers
1	5065-8	8 Drawer cabinet, square back
4	5070	Partskeeper carry case with holder, universal
1	6070	6" Hook, 3" opening, painted
1	6072	8" Swivel Hook, 4" opening, painted
2	6073	Large aluminum movable hook, 6.5" opening
2	7124	Reel Holder with two 5/8" diameter rods
1	7336	Square Back Bin Shelving Unit
2	7730	Locking door kit

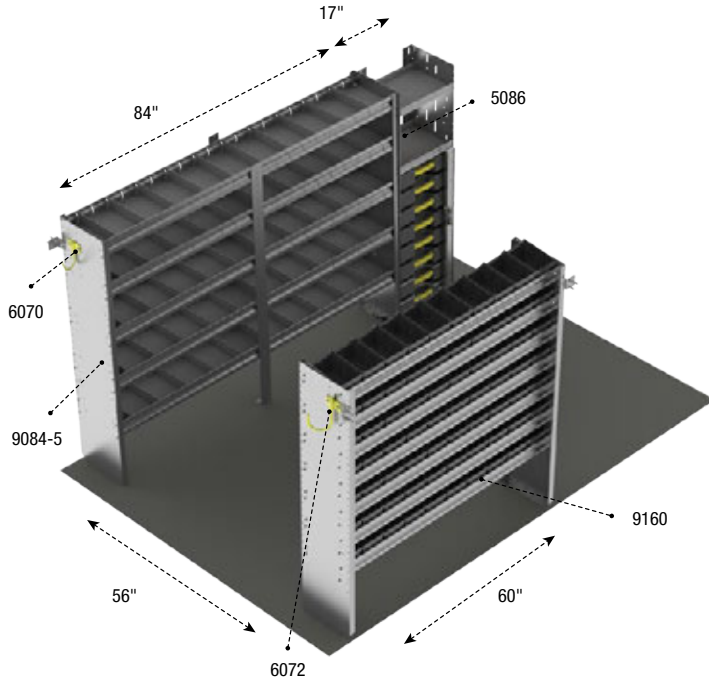

B115

Plumber Package

Aluminum

10+, 14+

310 lbs

3.6 hrs

Standard

No

Qty	Part #	Description
1	5086	Partskeeper cabinet with 8 carry cases & 2 shelves
1	6070	6" Hook, 3" opening, painted
1	6072	8" Swivel Hook, 4" opening, painted
1	9084-5	Square Back Shelving Unit with Dividers
1	9160	Square Back Bin Shelving Unit

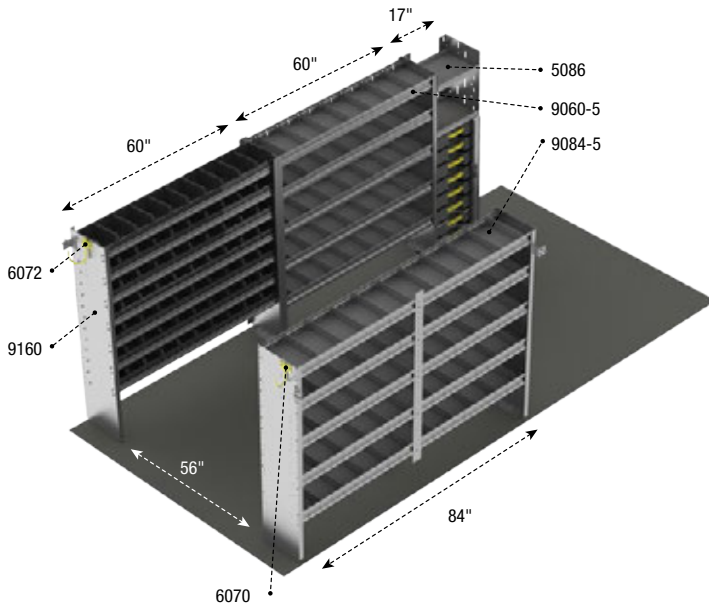

B215

Plumber Package

Aluminum

14+

405 lbs

4.7 hrs

Standard

No

Qty	Part #	Description
1	5086	Partskeeper cabinet with 8 carry cases & 2 shelves
1	6070	6" Hook, 3" opening, painted
1	6072	8" Swivel Hook, 4" opening, painted
1	9060-5	Square Back Shelving Unit with Dividers
1	9084-5	Square Back Shelving Unit with Dividers
1	9160	Square Back Bin Shelving Unit



BOX TRUCK & TRAILER

PACKAGES

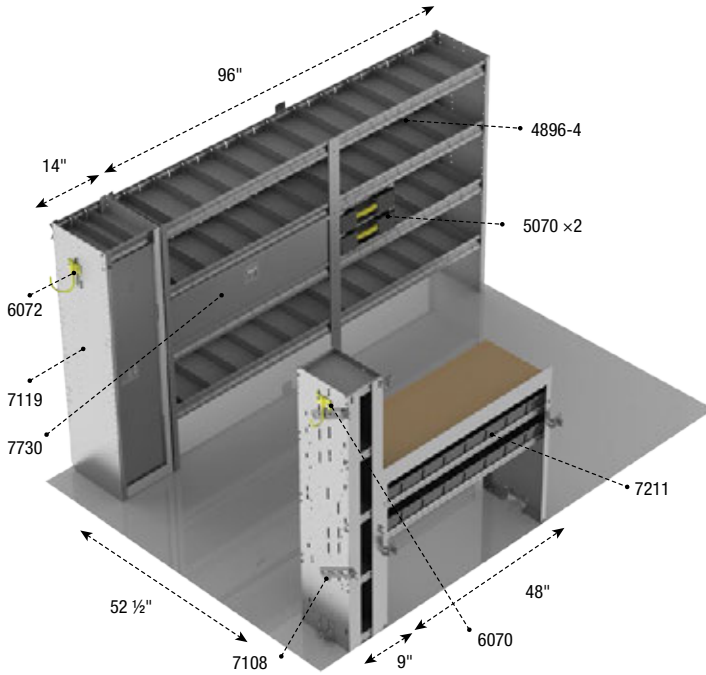

B116

Service Package

Aluminum

10+, 14+	283 lbs	5.2 hrs
Standard	No	

Qty	Part #	Description
1	4896-4	Square Back Shelving Unit with Dividers
2	5070	Partskeeper carry case with holder, universal
1	6070	6" Hook, 3" opening, painted
1	6072	8" Swivel Hook, 4" opening, painted
1	7108	Bookshelf
1	7119	Square back locker w/top shelf
1	7211	Workbench w/hardwood top, 2 bin shelves
1	7730	Locking door kit

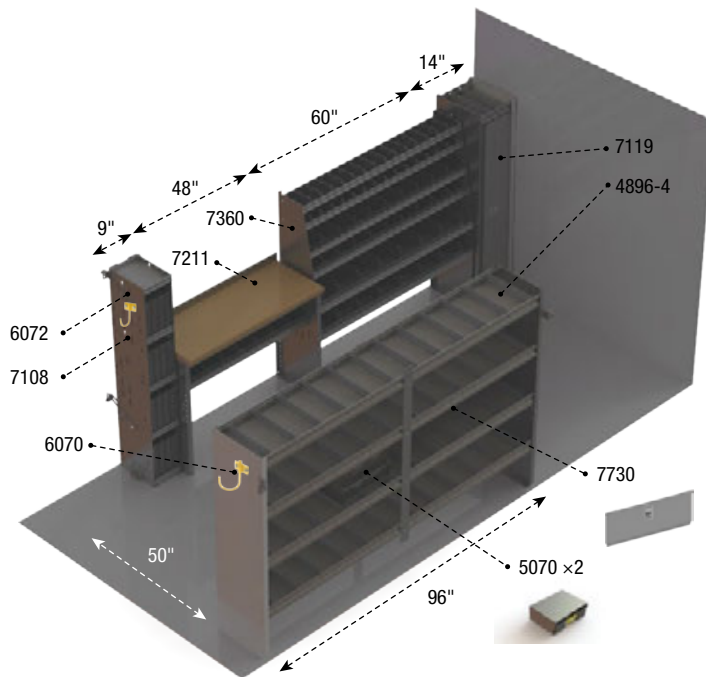

B216

Service Package

Aluminum

14+	365 lbs	6.2 hrs
Standard	No	

Qty	Part #	Description
1	4896-4	Square Back Shelving Unit with Dividers
2	5070	Partskeeper carry case with holder, universal
1	6070	6" Hook, 3" opening, painted
1	6072	8" Swivel Hook, 4" opening, painted
1	7108	Bookshelf
1	7119	Square back locker w/top shelf
1	7211	Workbench w/hardwood top, 2 bin shelves
1	7360	Square Back Bin Shelving Unit
1	7730	Locking door kit

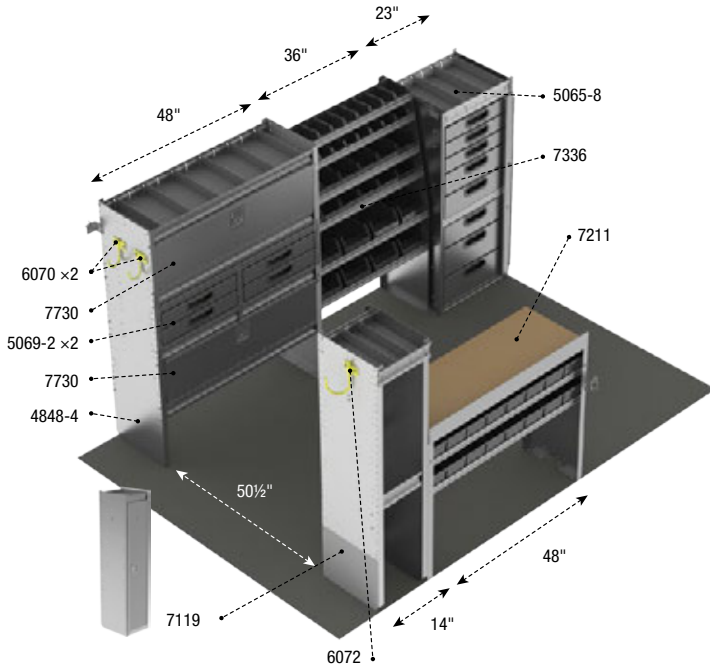

B117

WorkStation Package

Aluminum

10+, 14+

493 lbs

7.8 hrs

Standard

No

Qty	Part #	Description
1	4848-4	Square Back Shelving Unit with Dividers
1	5065-8	8 Drawer cabinet, square back
2	5069-2	2 Drawer cabinet
2	6070	6" Hook, 3" opening, painted
1	6072	8" Swivel Hook, 4" opening, painted
1	7119	Square back locker w/top shelf
1	7211	Workbench w/hardwood top, 2 bin shelves
1	7336	Square Back Bin Shelving Unit
2	7730	Locking door kit

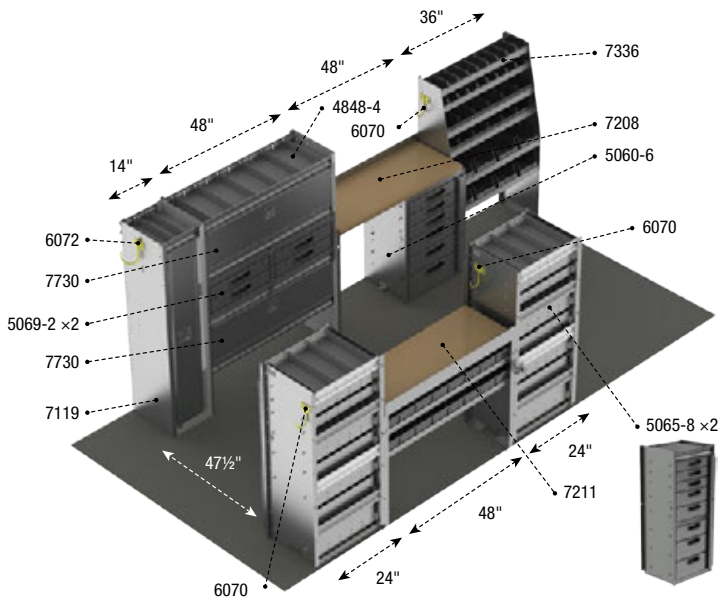

B217

WorkStation Package

Aluminum

14+

823 lbs

10.5 hrs

Standard

No

Qty	Part #	Description
1	4848-4	Square Back Shelving Unit with Dividers
1	5060-6	6 Drawer cabinet
2	5065-8	8 Drawer cabinet, square back
2	5069-2	2 Drawer cabinet
3	6070	6" Hook, 3" opening, painted
1	6072	8" Swivel Hook, 4" opening, painted
1	7119	Square back locker w/top shelf
1	7208	Workbench w/hardwood top, one end panel
1	7211	Workbench w/hardwood top, 2 bin shelves
1	7336	Square Back Bin Shelving Unit
2	7730	Locking door kit

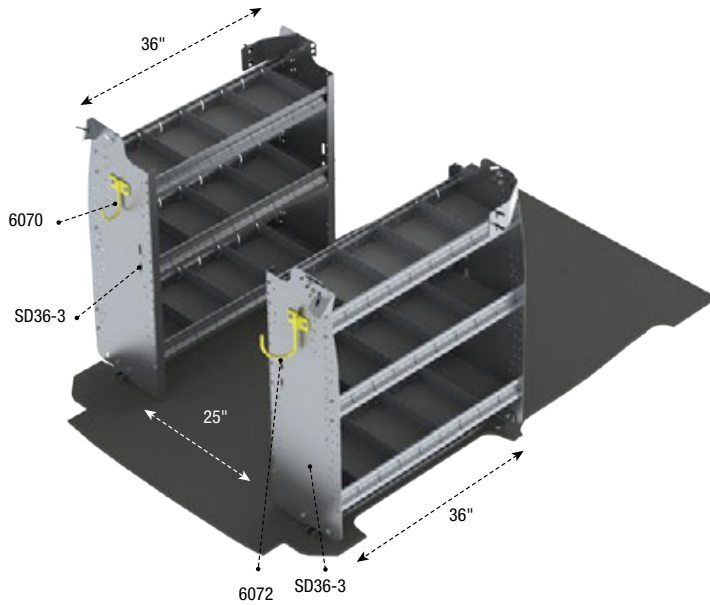

W010

Contractor Package

Aluminum

115"	73 lbs	2 hrs
Standard	Yes	

Qty Part # Description

1	6070	6" Hook, 3" opening, painted
1	6072	8" Swivel Hook, 4" opening, painted
2	SD36-3	Contoured Shelving Unit with Dividers

Drill-free installation

PACKAGES

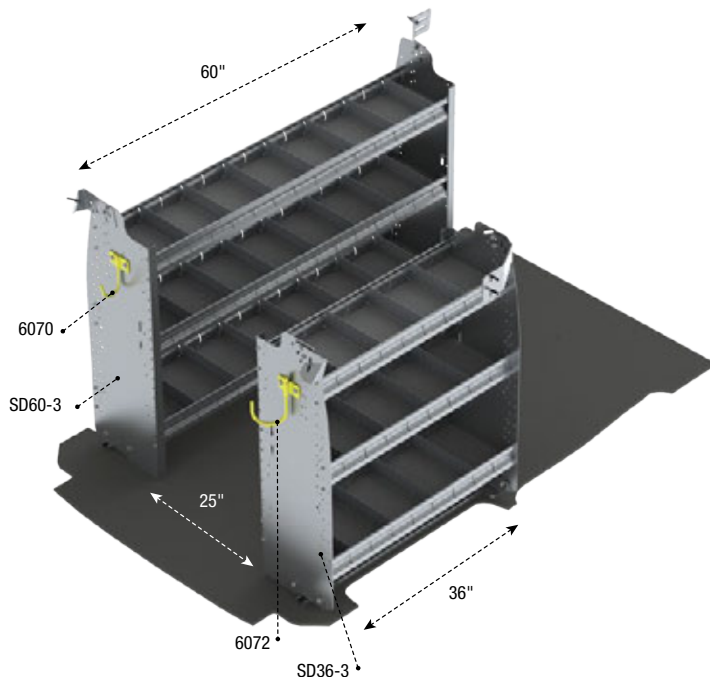

W110

Deluxe Contractor Package

Aluminum

115"	89 lbs	2 hrs
Standard	Yes	

Qty Part # Description

1	6070	6" Hook, 3" opening, painted
1	6072	8" Swivel Hook, 4" opening, painted
1	SD36-3	Contoured Shelving Unit with Dividers
1	SD60-3	Contoured Shelving Unit with Dividers

Drill-free installation



W010

Contractor Package

*Preproduction model shown, do not use as an installation guide.



QUIET

The combination of the extrusion, shelf tray, and end-panels create durable, vibration-free shelves.

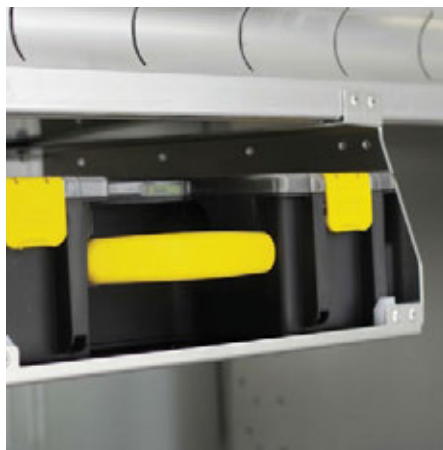

EFFICIENT

Ergonomic design reduces injuries and increases productivity.

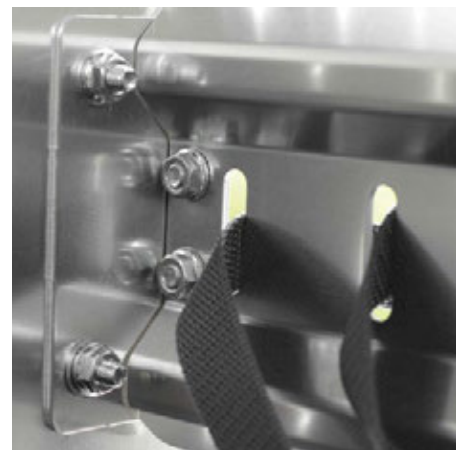

TOUGH

Extrusion builds durability into shelf.

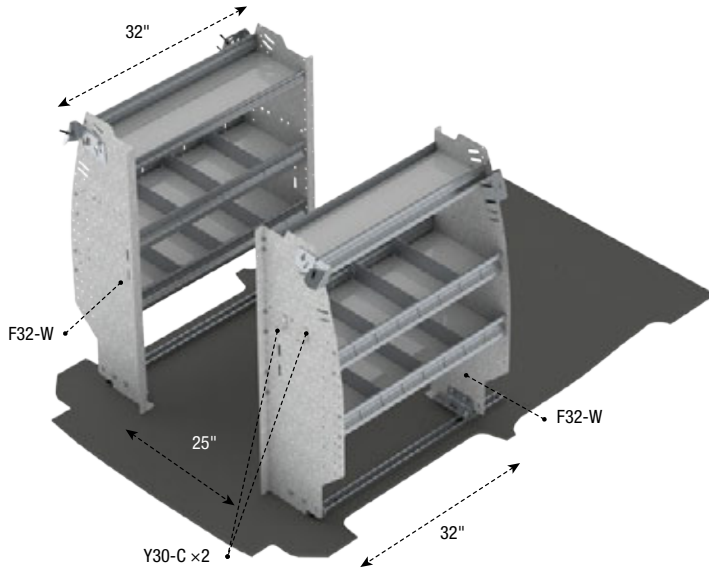

Z10-BW

Base Contractor Package

Steel

115"	96 lbs	2.4 hrs
Standard	Yes	

Qty	Part #	Description
2	F32-W	Contoured Shelving Unit with Dividers
2	Y30-C	Coat Hook, 1" opening, chrome plated

Drill-free installation

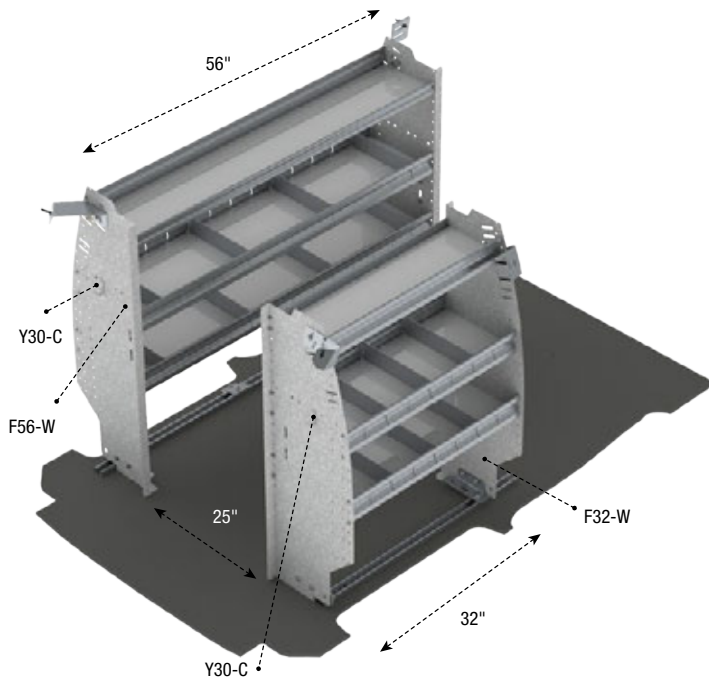

Z10-DW

Deluxe Contractor Package

Steel

115"	114 lbs	2.4 hrs
Standard	Yes	

Qty	Part #	Description
1	F32-W	Contoured Shelving Unit with Dividers
1	F56-W	Contoured Shelving Unit with Dividers
2	Y30-C	Coat Hook, 1" opening, chrome plated

Drill-free installation

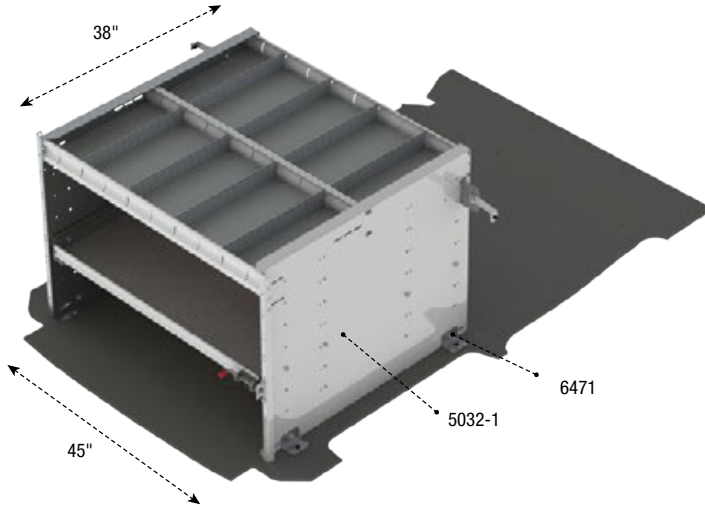

W019

Delivery Package

Aluminum

115"	89 lbs	1 hr
Standard	Yes	

Qty	Part #	Description
1	5032-1	Access Tray with 1 shelf / 1 drawer
1	6471	Access Tray install kit

Drill-free installation

PACKAGES

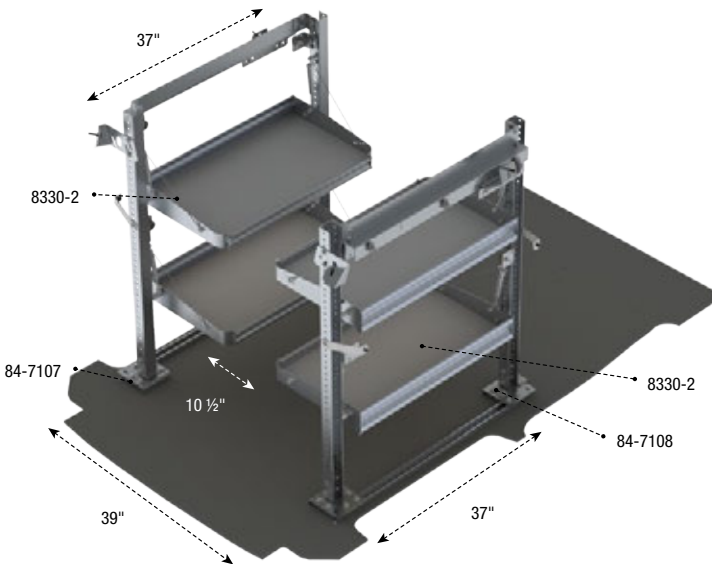

W119

Deluxe Delivery Package

Aluminum

115"	90 lbs	2.6 hrs
Standard	Yes	

Qty	Part #	Description
2	8330-2	Fold-Away Shelving
1	84-7107	Fold-Away shelving install kit, driver side
1	84-7108	Fold-Away shelving install kit, passenger side

Drill-free installation

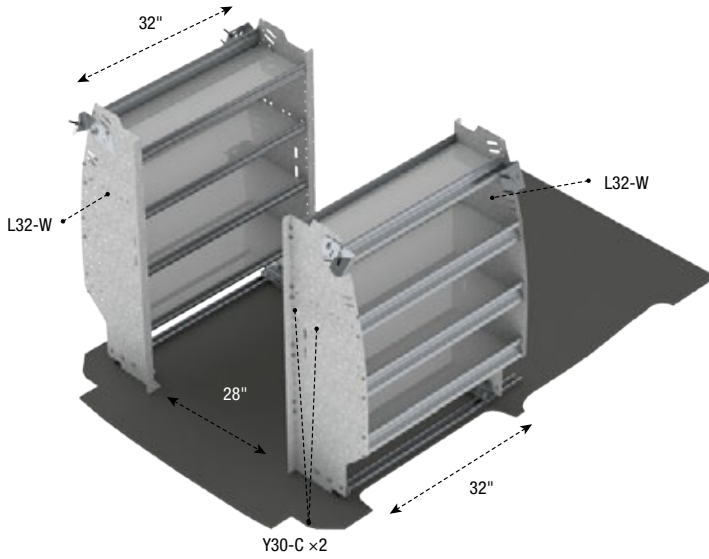

Z19-BW

Delivery Package

Steel

115"	110 lbs	2.4 hrs
Standard	Yes	

Qty	Part #	Description
2	L32-W	Contoured Shelving Unit
2	Y30-C	Coat Hook, 1" opening, chrome plated

Drill-free installation

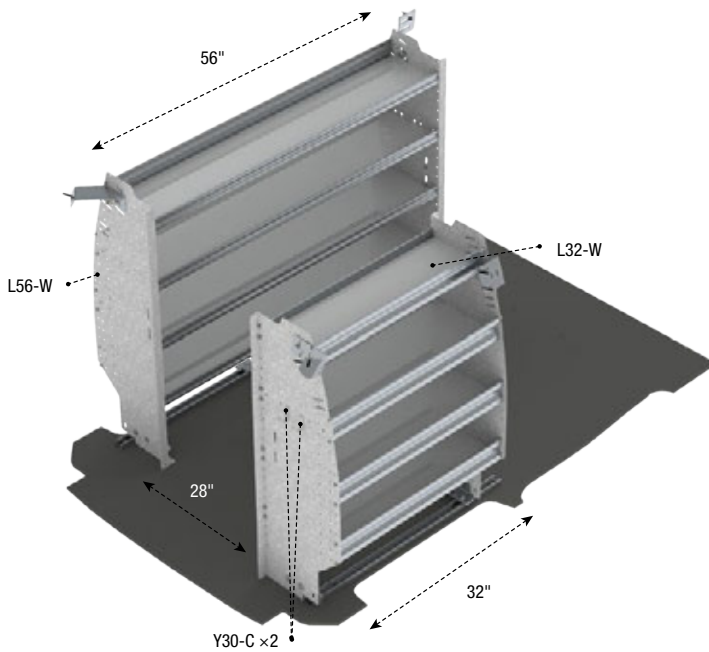

Z19-DW

Deluxe Delivery Package

Steel

115"	133 lbs	2.4 hrs
Standard	Yes	

Qty	Part #	Description
1	L32-W	Contoured Shelving Unit
1	L56-W	Contoured Shelving Unit
2	Y30-C	Coat Hook, 1" opening, chrome plated

Drill-free installation

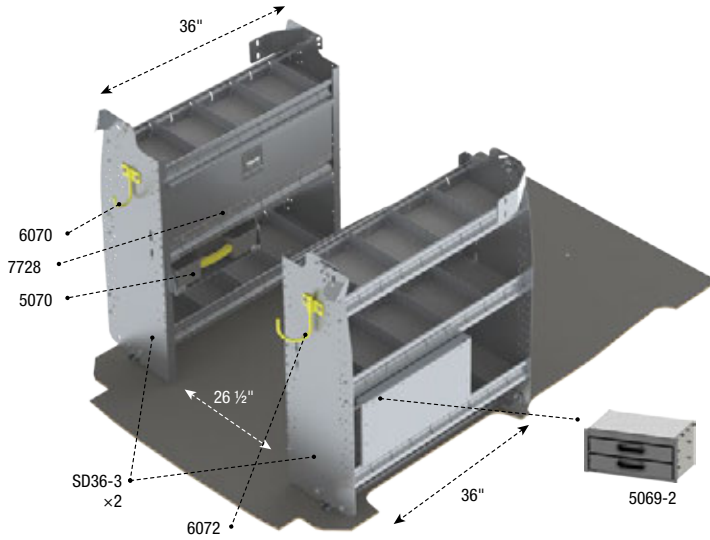

W011

Electrical Package

Aluminum

115"	120 lbs	3.3 hrs
Standard	Yes	

Qty	Part #	Description
1	5069-2	2 Drawer cabinet
1	5070	Partskeeper carry case with holder, universal
1	6070	6" Hook, 3" opening, painted
1	6072	8" Swivel Hook, 4" opening, painted
1	7728	Locking door kit
2	SD36-3	Contoured Shelving Unit with Dividers

Drill-free installation

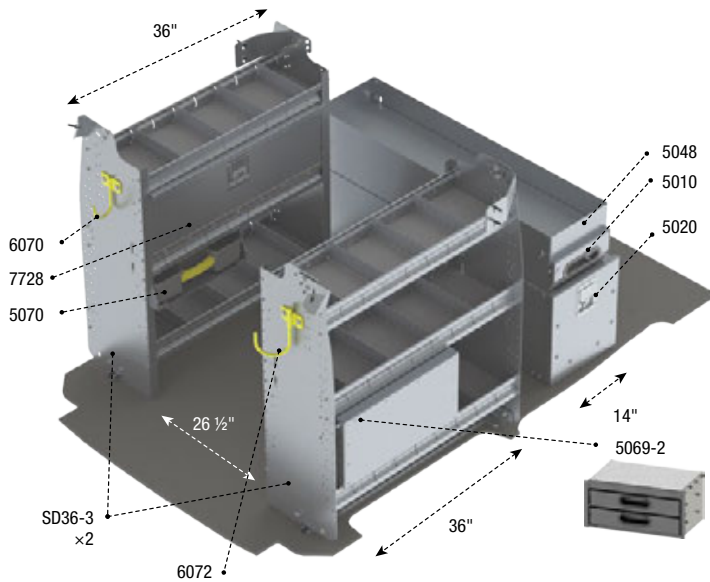

W111

Deluxe Electrical Package

Aluminum

115"	201 lbs	5 hrs
Standard	Yes	

Qty	Part #	Description
1	5010	Partslider drawer
1	5020	Tool drawer
1	5048	Top edge, for 5010 Partslider
1	5069-2	2 Drawer cabinet
1	5070	Partskeeper carry case with holder, universal
1	6070	6" Hook, 3" opening, painted
1	6072	8" Swivel Hook, 4" opening, painted
1	7728	Locking door kit
2	SD36-3	Contoured Shelving Unit with Dividers

Drill-free installation except for the drawers that are not a drill-free installation.

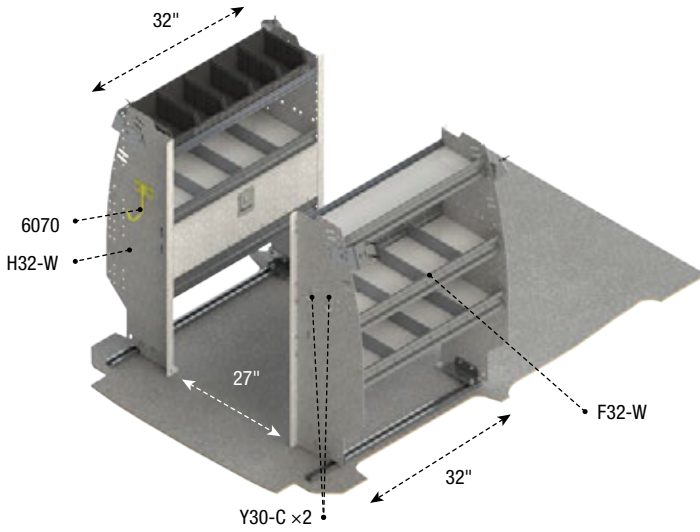

Z11-BW

Base Electrical Package

Steel

115"	107 lbs	2.6 hrs
Standard	Yes	

Qty	Part #	Description
1	6070	6" Hook, 3" opening, painted
1	F32-W	Contoured Shelving Unit with Dividers
1	H32-W	Contoured Bin Shelving Unit
2	Y30-C	Coat Hook, 1" opening, chrome plated

Drill-free installation

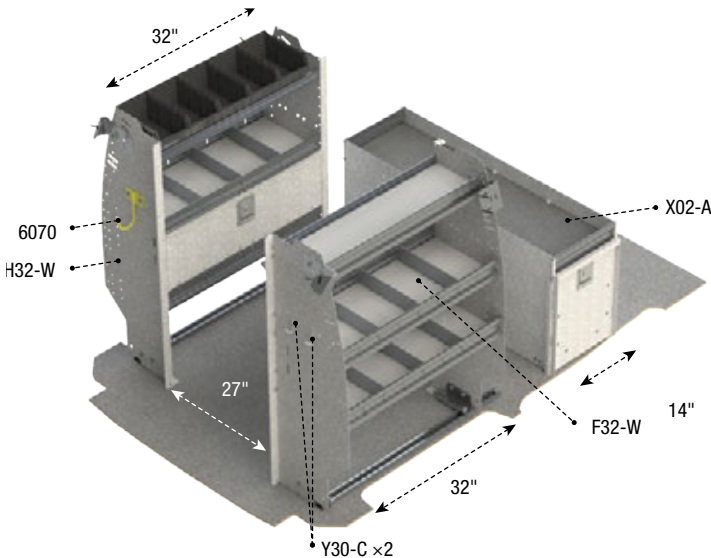

Z11-DW

Deluxe Electrical Package

Steel

115"	187 lbs	3.6 hrs
Standard	Yes	

Qty	Part #	Description
1	6070	6" Hook, 3" opening, painted
1	F32-W	Contoured Shelving Unit with Dividers
1	H32-W	Contoured Bin Shelving Unit
1	X02-A	Fleetline Tool Drawer
2	Y30-C	Coat Hook, 1" opening, chrome plated

Drill-free installation except for the drawers that are not a drill-free installation.

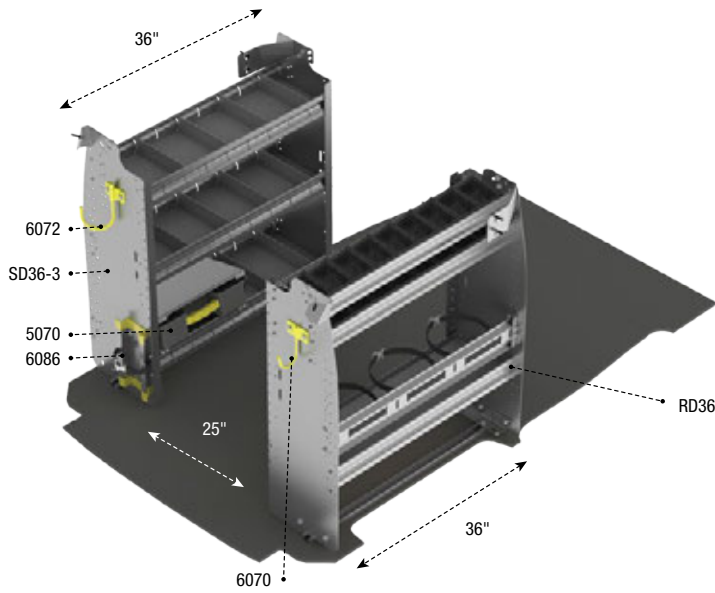

W012

HVAC Package

Aluminum

115"	73 lbs	3 hrs
Standard	No	

Qty	Part #	Description
1	5070	Partskeeper carry case with holder, universal
1	6070	6" Hook, 3" opening, painted
1	6072	8" Swivel Hook, 4" opening, painted
1	6086	Small aluminum bottle holder, with a black nylon strap
1	RD36	Contoured Refrigerant Bin Unit
1	SD36-3	Contoured Shelving Unit with Dividers

Drill-free installation

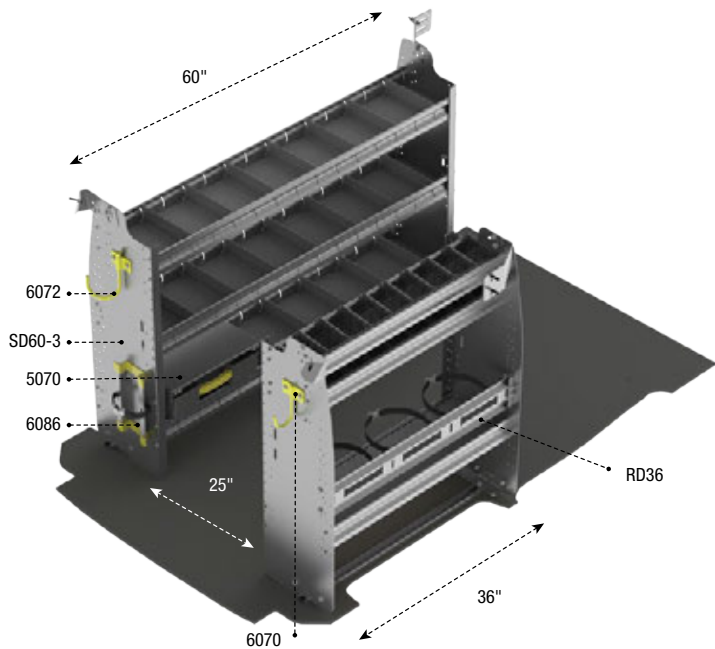

W112

Deluxe HVAC Package

Aluminum

115"	89 lbs	3 hrs
Standard	No	

Qty	Part #	Description
1	5070	Partskeeper carry case with holder, universal
1	6070	6" Hook, 3" opening, painted
1	6072	8" Swivel Hook, 4" opening, painted
1	6086	Small aluminum bottle holder, with a black nylon strap
1	RD36	Contoured Refrigerant Bin Unit
1	SD60-3	Contoured Shelving Unit with Dividers

Drill-free installation

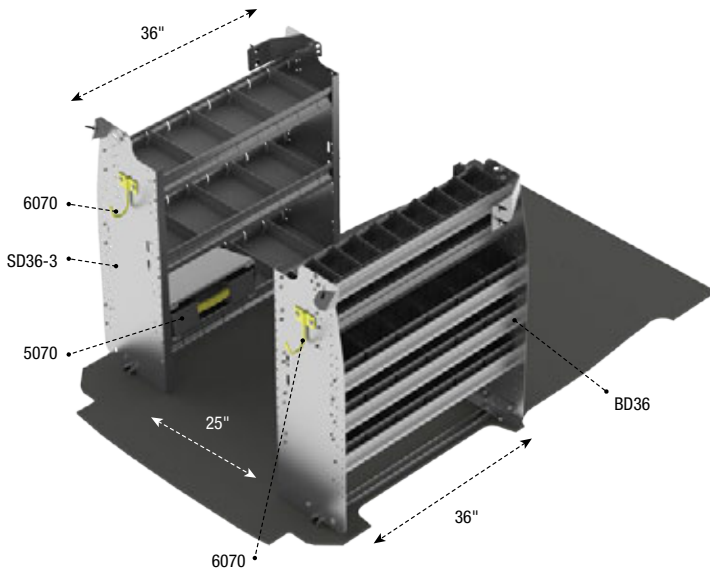

W016

Service Package

Aluminum

115"	93 lbs	2.5 hrs
Standard	Yes	

Qty	Part #	Description
1	5070	Partskeeper carry case with holder, universal
2	6070	6" Hook, 3" opening, painted
1	BD36	Contoured Bin Shelving Unit
1	SD36-3	Contoured Shelving Unit with Dividers

Drill-free installation

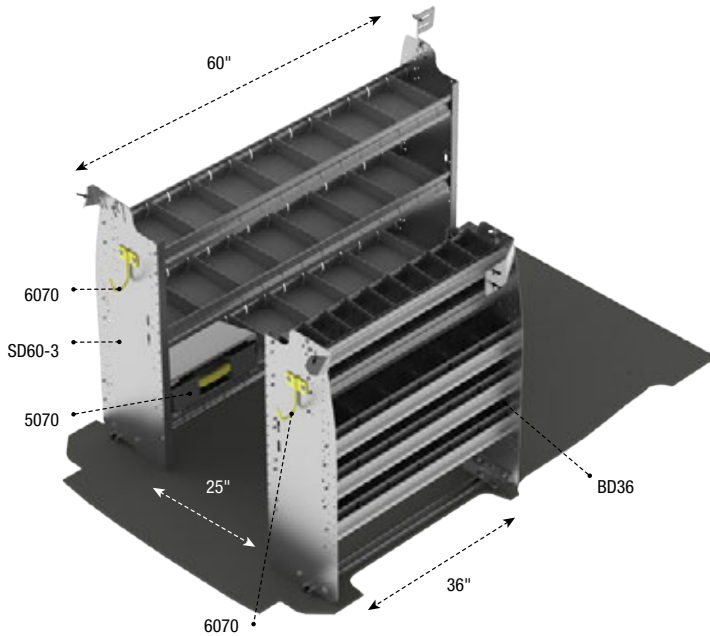

W116

Deluxe Service Package

Aluminum

115"	109 lbs	2.5 hrs
Standard	Yes	

Qty	Part #	Description
1	5070	Partskeeper carry case with holder, universal
2	6070	6" Hook, 3" opening, painted
1	BD36	Contoured Bin Shelving Unit
1	SD60-3	Contoured Shelving Unit with Dividers

Drill-free installation

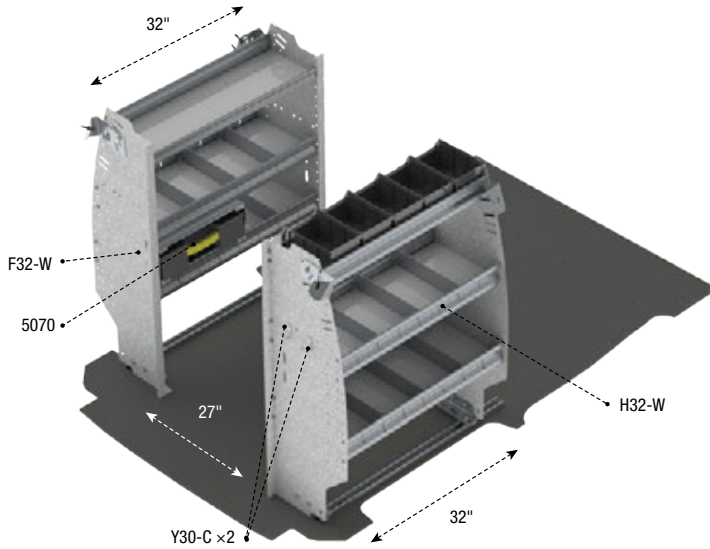

Z16-BW

Base Service Package

Steel

115"	113 lbs	2.7 hrs
Standard	Yes	

Qty	Part #	Description
1	5070	Partskeeper carry case with holder, universal
1	F32-W	Contoured Shelving Unit with Dividers
1	H32-W	Contoured Bin Shelving Unit
2	Y30-C	Coat Hook, 1" opening, chrome plated

Drill-free installation

PACKAGES

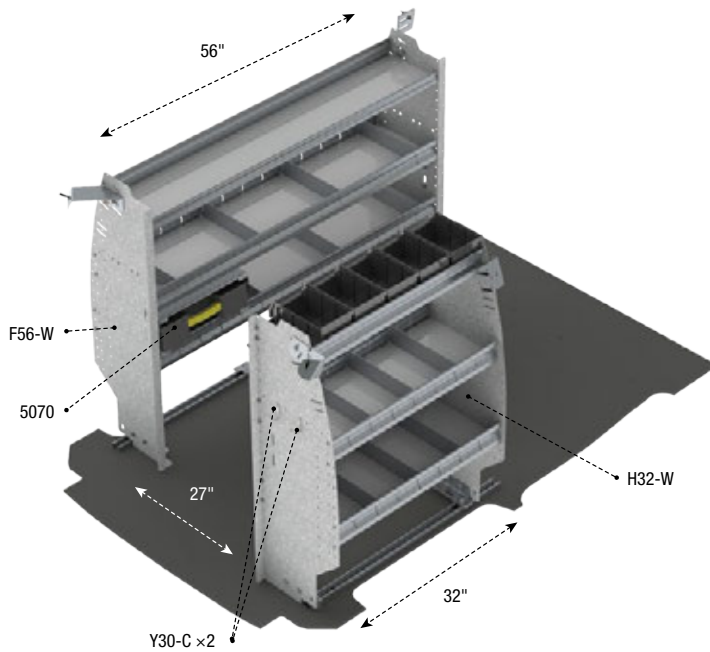

Z16-DW

Deluxe Service Package

Steel

115"	131 lbs	2.7 hrs
Standard	Yes	

Qty	Part #	Description
1	5070	Partskeeper carry case with holder, universal
1	F56-W	Contoured Shelving Unit with Dividers
1	H32-W	Contoured Bin Shelving Unit
2	Y30-C	Coat Hook, 1" opening, chrome plated

Drill-free installation

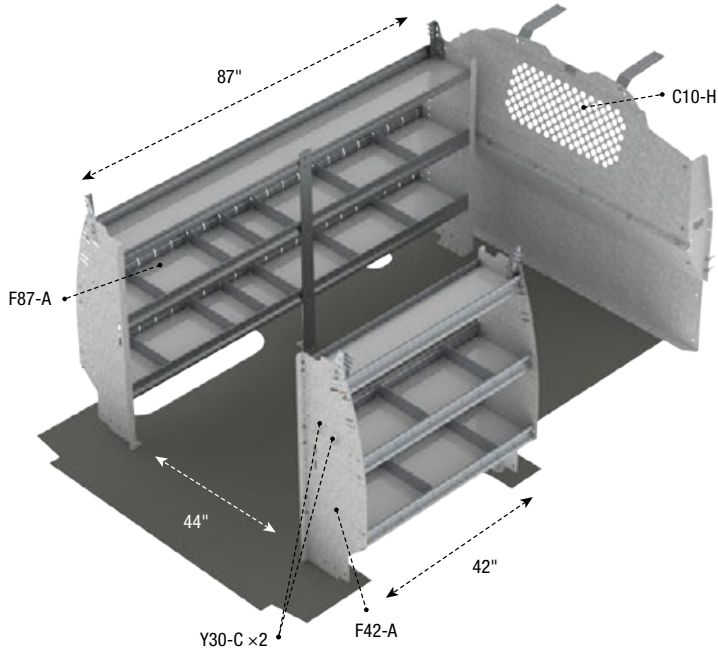

Z05-H

Base Contractor Package

Steel

135", 155"

204 lbs

3.4 hrs

Standard

Yes

Qty	Part #	Description
1	C10-H	Contoured Safety Partition with Perforated Window
1	F42-A	Contoured Shelving Unit with Dividers
1	F87-A	Contoured Shelving Unit with Dividers
2	Y30-C	Coat Hook, 1" opening, chrome plated

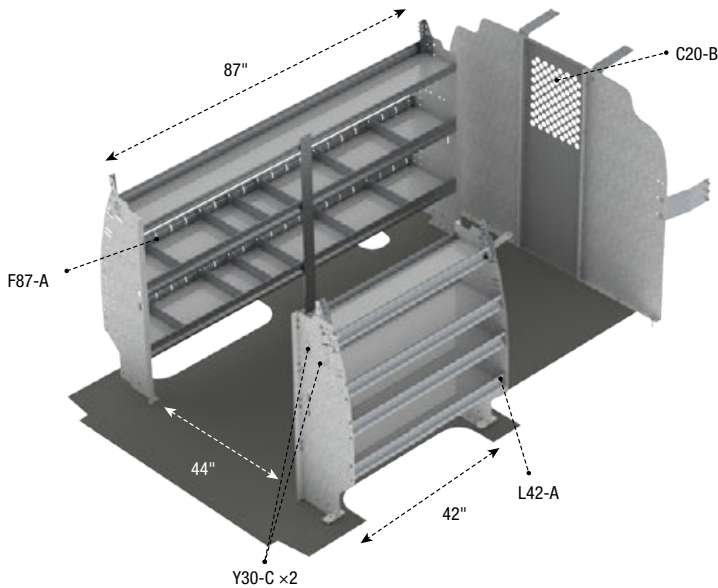

Z10-H

Base Contractor Package

Steel

135", 155"

215 lbs

3.4 hrs

Standard

No

Qty	Part #	Description
1	C20-B	Straight Partition with Perforated Window, No Access
1	F87-A	Contoured Shelving Unit with Dividers
1	L42-A	Contoured Shelving Unit
2	Y30-C	Coat Hook, 1" opening, chrome plated

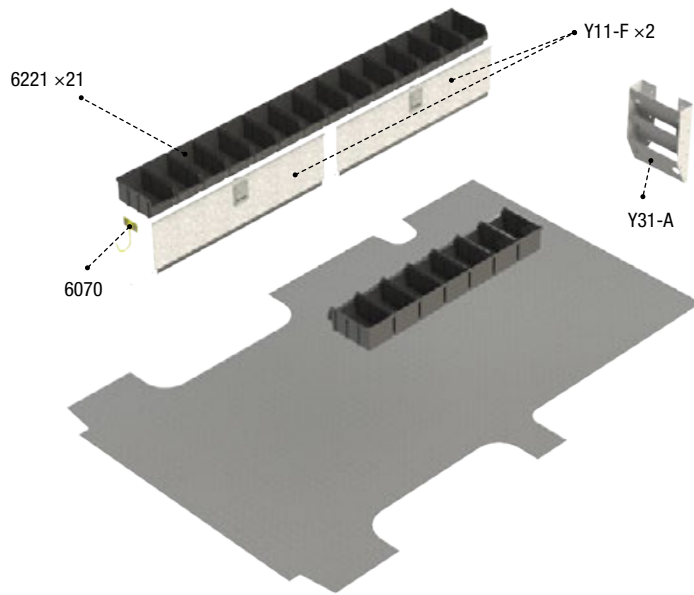

Z30-H

Contractor Package

Steel

135", 155"	47 lbs	1.4 hrs
Standard	Yes	

Qty	Part #	Description
1	6070	6" Hook, 3" opening, painted
21	6221	Medium Bin, Graphite
2	Y11-F	Locking door kit
1	Y31-A	Paper Holder, extra deep, 3 slots

PACKAGES

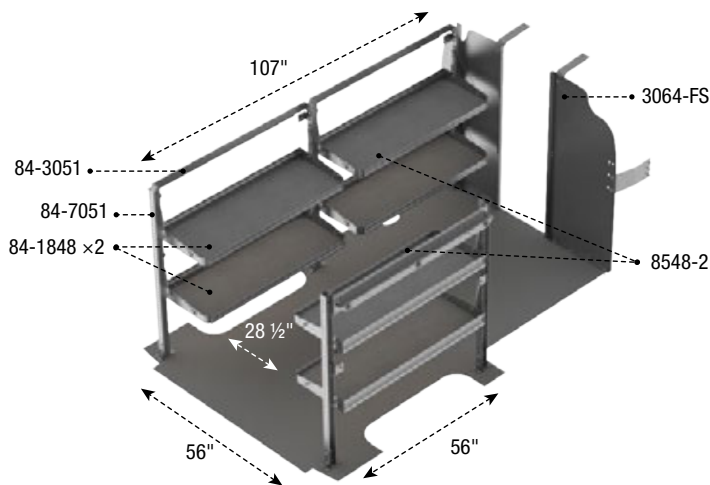

A019

Extended Length Delivery Package

Aluminum

155"	180 lbs	4.5 hrs
Standard	No	

Qty	Part #	Description
1	3064-FS	Straight Walk Through Partition
2	84-1848	Fold-Away Shelf Tray with Gas Shocks and Hardware
1	84-3051	Mounting Bar Assembly for Fold-Away Shelving
1	84-7051	Post Assembly for Fold-Away Shelving
2	8548-2	Fold-Away Shelving

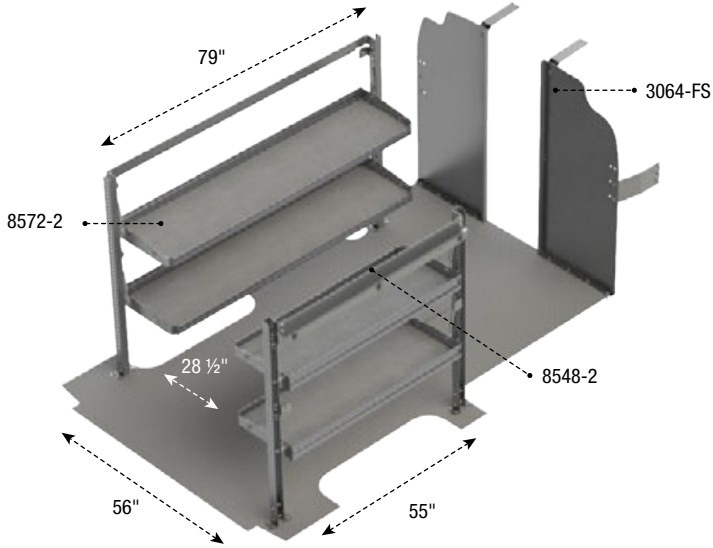

A119

Delivery Package

Aluminum

135", 155"

152 lbs

3.5 hrs

Standard

No

Qty	Part #	Description
1	3064-FS	Straight Walk Through Partition
1	8548-2	Fold-Away Shelving
1	8572-2	Fold-Away Shelving

A011

Deluxe Electrical Package

Aluminum

135", 155"

298 lbs

7.2 hrs

Standard

No

Qty	Part #	Description
1	3010-GS	Contoured Safety Partition
1	4096-3	Contoured Shelving Unit with Dividers
1	5010	Partslider drawer
1	5020	Tool drawer
1	5048	Top edge, for 5010 Partslider
2	5070	Partskeeper carry case with holder, universal
1	5248	Contoured Bin Shelving Unit
1	6070	6" Hook, 3" opening, painted
1	6072	8" Swivel Hook, 4" opening, painted
2	6073	Large aluminum movable hook, 6.5" opening
1	7124	Reel Holder with two 5/8" diameter rods
1	7720	Locking door kit
1	7740	Shelf Block

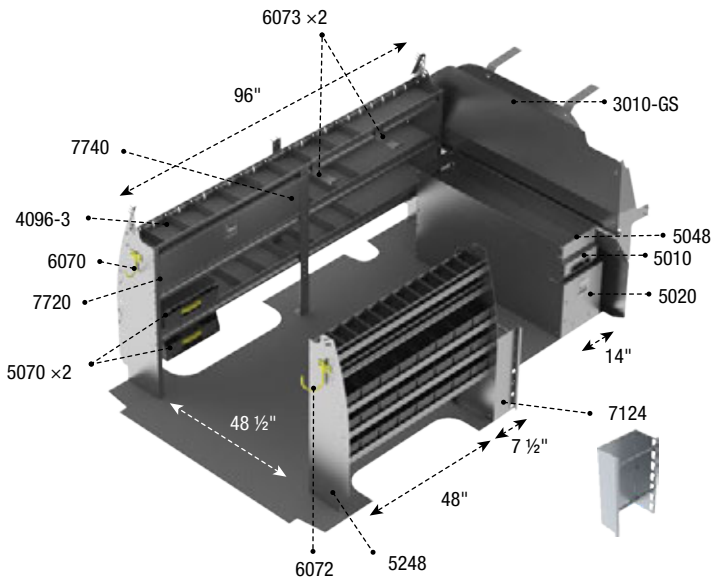

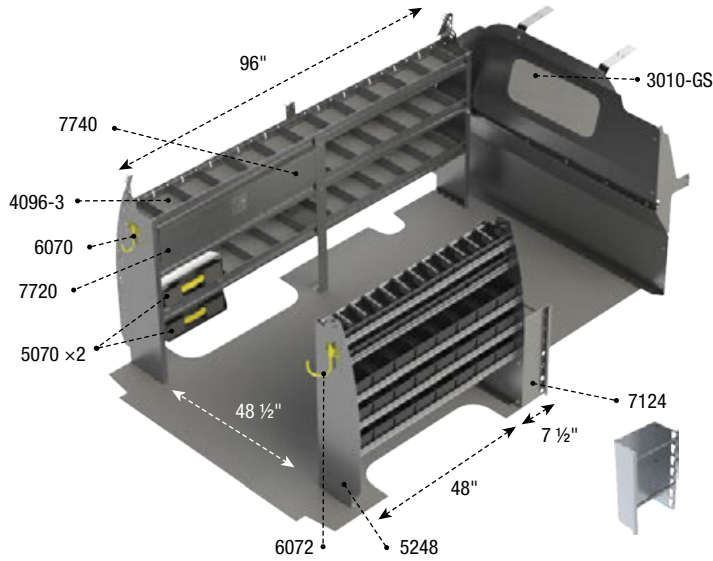

A111

Base Electrical Package

Aluminum

135", 155"	215 lbs	5.5 hrs
Standard	No	

Qty Part # Description

1	3010-GS	Contoured Safety Partition
1	4096-3	Contoured Shelving Unit with Dividers
2	5070	Partskeeper carry case with holder, universal
1	5248	Contoured Bin Shelving Unit
1	6070	6" Hook, 3" opening, painted
1	6072	8" Swivel Hook, 4" opening, painted
1	7124	Reel Holder with two 5/8" diameter rods
1	7720	Locking door kit
1	7740	Shelf Block

PACKAGES

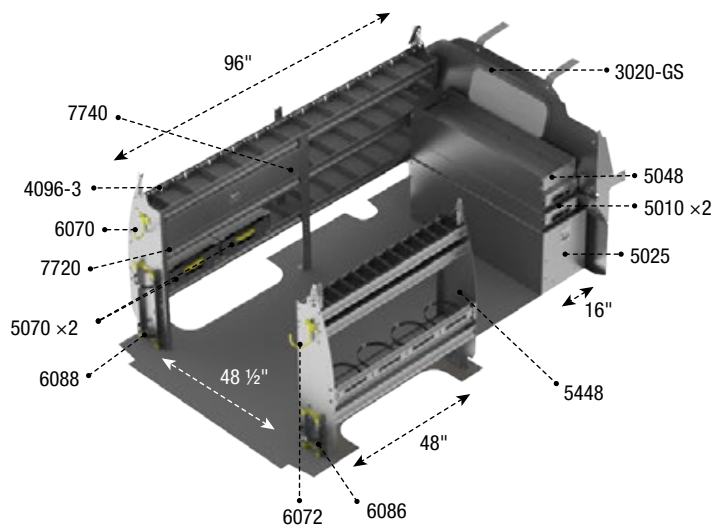

A012

Deluxe HVAC Package

Aluminum

135", 155"	323 lbs	7.6 hrs
Standard	No	

Qty Part # Description

1	3020-GS	Contoured Safety Partition with Tempered Glass Window
1	4096-3	Contoured Shelving Unit with Dividers
2	5010	Partslider drawer
1	5025	Jumbo tool drawer
1	5048	Top edge, for 5010 Partslider
2	5070	Partskeeper carry case with holder, universal
1	5448	Contoured Refrigerant Bin Unit
1	6070	6" Hook, 3" opening, painted
1	6072	8" Swivel Hook, 4" opening, painted
1	6086	Small aluminum bottle holder, with a black nylon strap
1	6088	Large aluminum bottle holder, with two black nylon straps
1	7720	Locking door kit
1	7740	Shelf Block

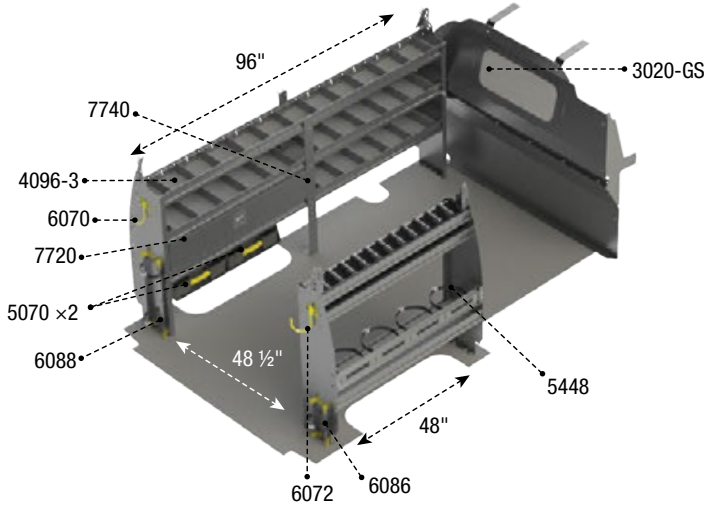

A112

Base HVAC Package

Aluminum

135", 155"

197 lbs

5.4 hrs

Standard

No

Qty	Part #	Description
1	3020-GS	Contoured Safety Partition with Tempered Glass Window
1	4096-3	Contoured Shelving Unit with Dividers
2	5070	Partskeeper carry case with holder, universal
1	5448	Contoured Refrigerant Bin Unit
1	6070	6" Hook, 3" opening, painted
1	6072	8" Swivel Hook, 4" opening, painted
1	6086	Small aluminum bottle holder, with a black nylon strap
1	6088	Large aluminum bottle holder, with two black nylon straps
1	7720	Locking door kit
1	7740	Shelf Block

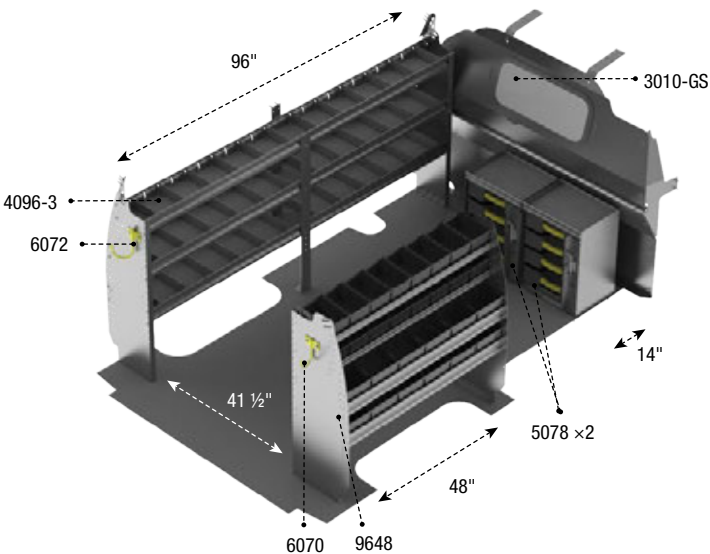

A015

Deluxe Plumber Package

Aluminum

135", 155"

234 lbs

4 hrs

Standard

Yes

Qty	Part #	Description
1	3010-GS	Contoured Safety Partition
1	4096-3	Contoured Shelving Unit with Dividers
2	5078	Partskeeper cabinet with 4 carry cases
1	6070	6" Hook, 3" opening, painted
1	6072	8" Swivel Hook, 4" opening, painted
1	9648	Contoured Bin Shelving Unit

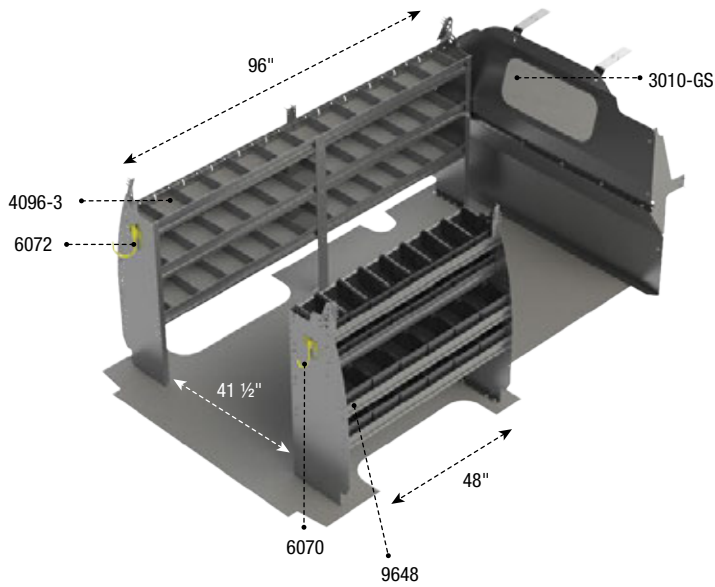

A115

Base Plumber Package

Aluminum

135", 155"	188 lbs	3.4 hrs
Standard	Yes	

Qty	Part #	Description
1	3010-GS	Contoured Safety Partition
1	4096-3	Contoured Shelving Unit with Dividers
1	6070	6" Hook, 3" opening, painted
1	6072	8" Swivel Hook, 4" opening, painted
1	9648	Contoured Bin Shelving Unit

PACKAGES

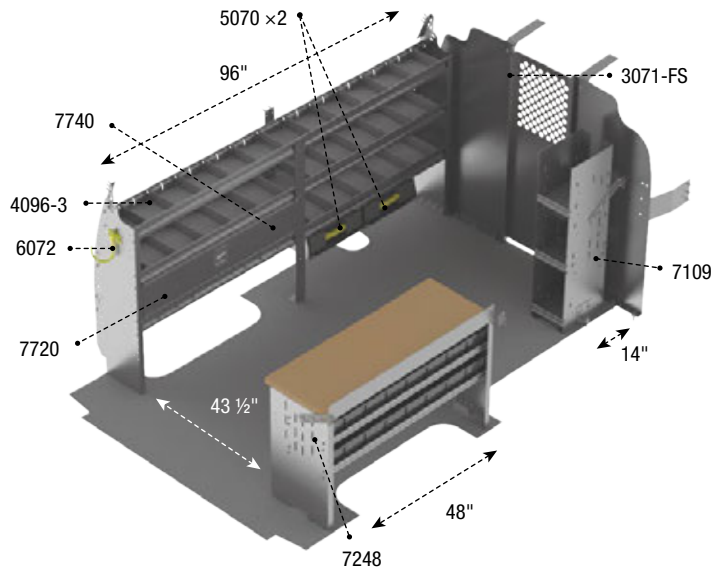

A016

Deluxe Service Package

Aluminum

135", 155"	242 lbs	5.6 hrs
Standard	No	

Qty	Part #	Description
1	3071-FS	Straight Partition with Perforated Window, Swing Door
1	4096-3	Contoured Shelving Unit with Dividers
2	5070	Partskeeper carry case with holder, universal
1	6072	8" Swivel Hook, 4" opening, painted
1	7109	Bookshelf
1	7248	Workbench w/hardwood top, 2 bin shelves
1	7720	Locking door kit
1	7740	Shelf Block

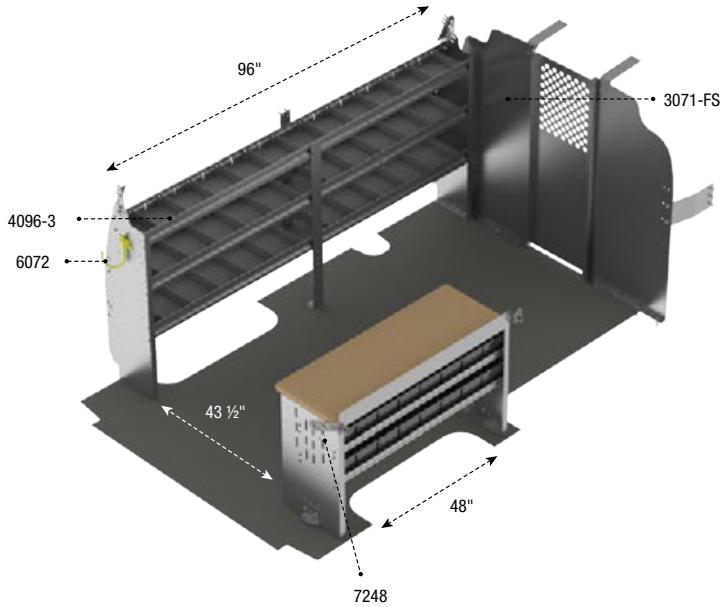

A116

Base Service Package

Aluminum

135", 155"	200 lbs	3.6 hrs
Standard	No	

Qty	Part #	Description
1	3071-FS	Straight Partition with Perforated Window, Swing Door
1	4096-3	Contoured Shelving Unit with Dividers
1	6072	8" Swivel Hook, 4" opening, painted
1	7248	Workbench w/hardwood top, 2 bin shelves

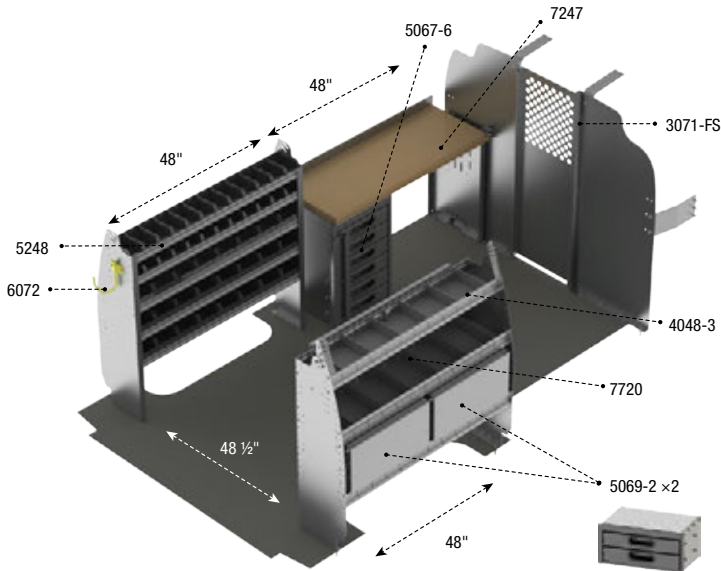

A017

Deluxe WorkStation Package

Aluminum

135", 155"	433 lbs	6.4 hrs
Standard	No	

Qty	Part #	Description
1	3071-FS	Straight Partition with Perforated Window, Swing Door
1	4048-3	Contoured Shelving Unit with Dividers
1	5067-6	6 Drawer cabinet
2	5069-2	2 Drawer cabinet
1	5248	Contoured Bin Shelving Unit
1	6072	8" Swivel Hook, 4" opening, painted
1	7247	Workbench w/hardwood top, one end panel
1	7720	Locking door kit

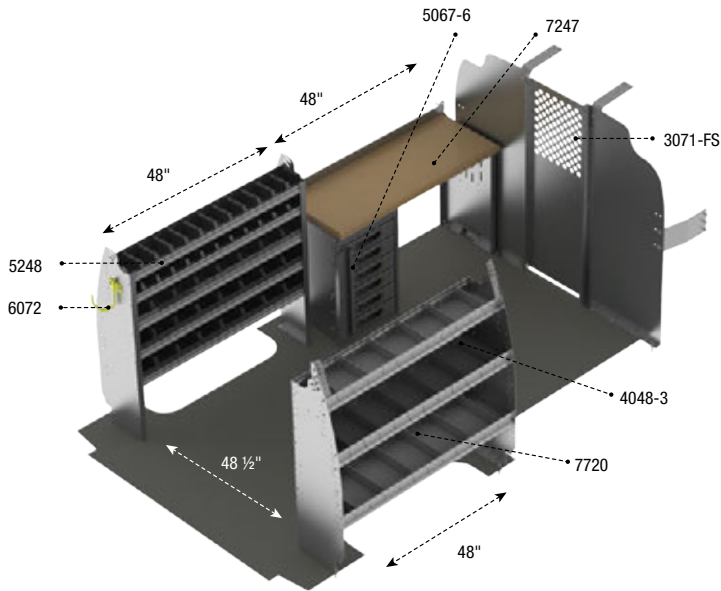

A117

Base WorkStation Package

Aluminum

135", 155"	303 lbs	5.4 hrs
Standard	No	

Qty	Part #	Description
1	3071-FS	Straight Partition with Perforated Window, Swing Door
1	4048-3	Contoured Shelving Unit with Dividers
1	5067-6	6 Drawer cabinet
1	5248	Contoured Bin Shelving Unit
1	6072	8" Swivel Hook, 4" opening, painted
1	7247	Workbench w/hardwood top, one end panel
1	7720	Locking door kit

PACKAGES



5248 Contoured Bin Shelving Unit



A011

Electrical Package

Efficient layout lets you find everything quickly and easily.



QUIET

The combination of the extrusion, shelf tray, and end-panels create durable, vibration-free shelves.



EFFICIENT

Ergonomic design reduces injuries and increases productivity.



TOUGH

Extrusion builds durability into shelf.

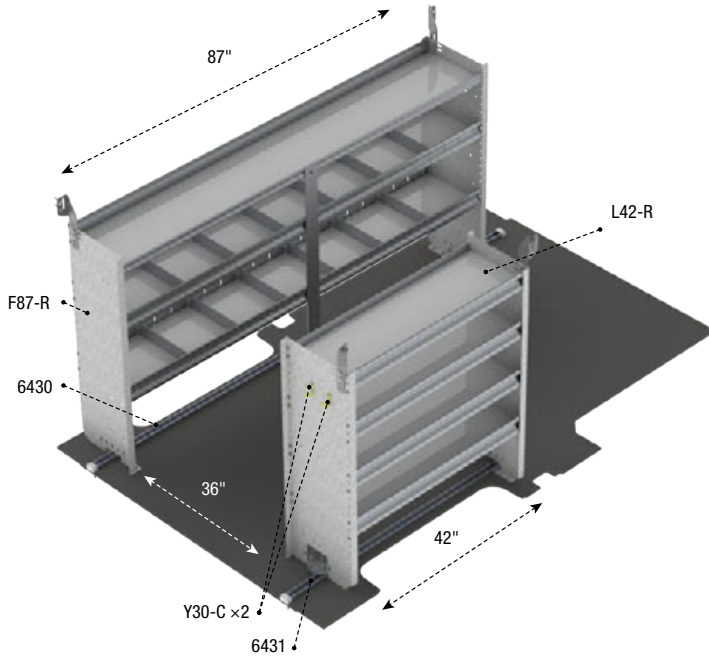

Z10-F1

Contractor Package

Steel

130"	199 lbs	2.9 hrs
Low	Yes	

Qty	Part #	Description
1	6430	Shelving install kit, driver side
1	6431	Shelving install kit, passenger side
1	F87-R	Square Back Shelving Unit with Dividers
1	L42-R	Square Back Shelving Unit
2	Y30-C	Coat Hook, 1" opening, chrome plated

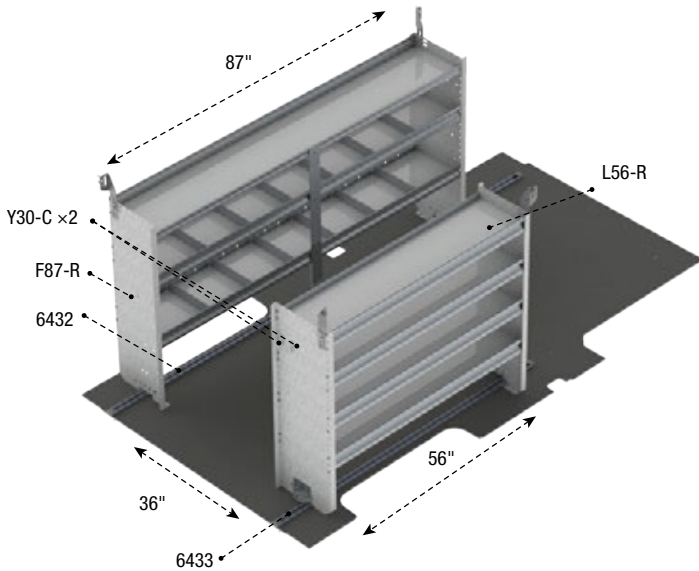

Z10-F2

Contractor Package

Steel

148"	212 lbs	2.9 hrs
Low	Yes	

Qty	Part #	Description
1	6432	Shelving install kit, driver side
1	6433	Shelving install kit, passenger side
1	F87-R	Square Back Shelving Unit with Dividers
1	L56-R	Square Back Shelving Unit
2	Y30-C	Coat Hook, 1" opening, chrome plated

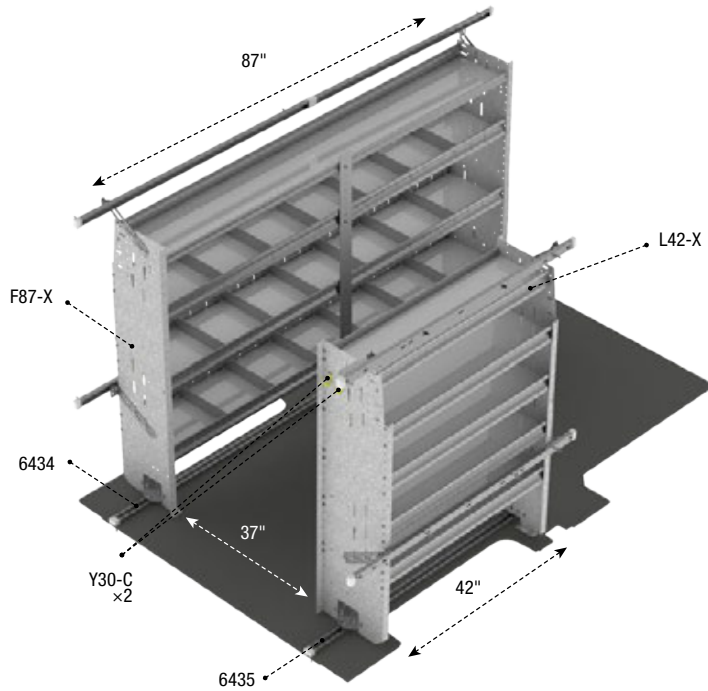

Z10-F3

Contractor Package

Steel

130"	223 lbs	3.1 hrs
Medium	Yes	

Qty	Part #	Description
1	6434	Shelving install kit, driver side
1	6435	Shelving install kit, passenger side
1	F87-X	Square Back Shelving Unit with Dividers
1	L42-X	Square Back Shelving Unit
2	Y30-C	Coat Hook, 1" opening, chrome plated

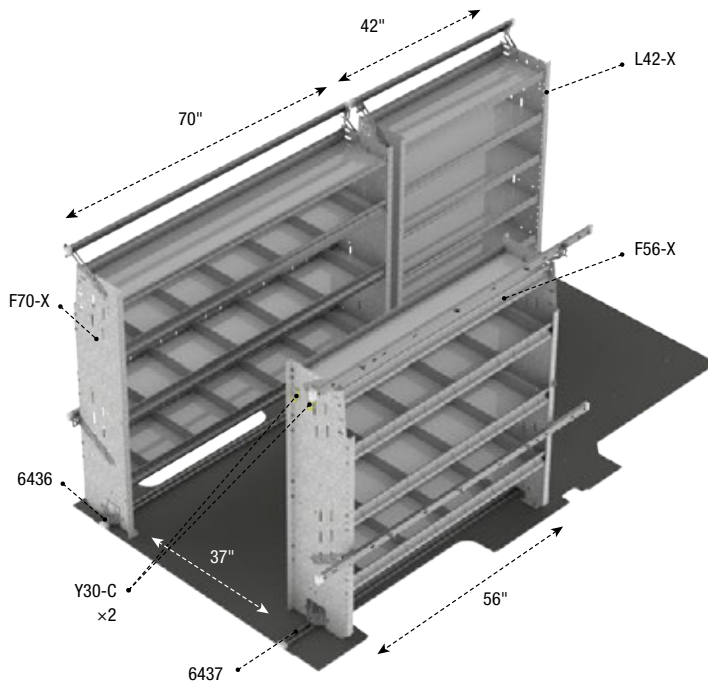

Z10-F4

Contractor Package

Steel

148"	288 lbs	4.1 hrs
Medium / High	Yes	

Qty	Part #	Description
1	6436	Shelving install kit, driver side
1	6437	Shelving install kit, passenger side
1	F56-X	Square Back Shelving Unit with Dividers
1	F70-X	Square Back Shelving Unit with Dividers
1	L42-X	Square Back Shelving Unit
2	Y30-C	Coat Hook, 1" opening, chrome plated

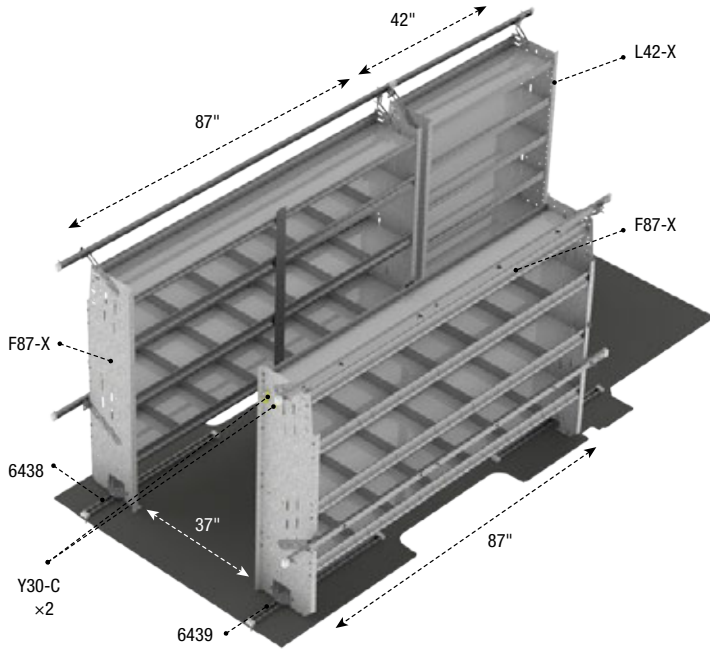

Z10-F5

Contractor Package

Steel

148" Ext	348 lbs	4.1 hrs
High	Yes	

Qty	Part #	Description
1	6438	Shelving install kit, driver side
1	6439	Shelving install kit, passenger side
2	F87-X	Square Back Shelving Unit with Dividers
1	L42-X	Square Back Shelving Unit
2	Y30-C	Coat Hook, 1" opening, chrome plated

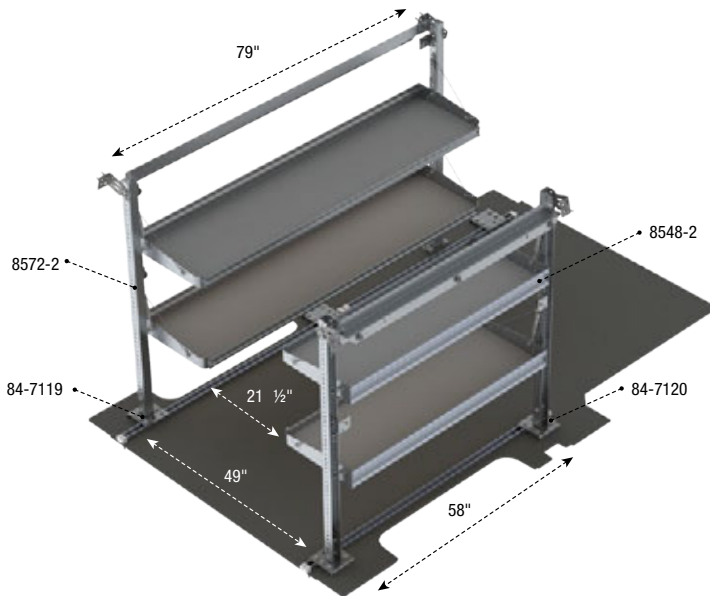

F119

Delivery Package

Aluminum

130"	138 lbs	5.1 hrs
Low	Yes	

Qty	Part #	Description
1	84-7119	Fold-Away install kit, driver side
1	84-7120	Fold-Away install kit, passenger side
1	8548-2	Fold-Away Shelving
1	8572-2	Fold-Away Shelving

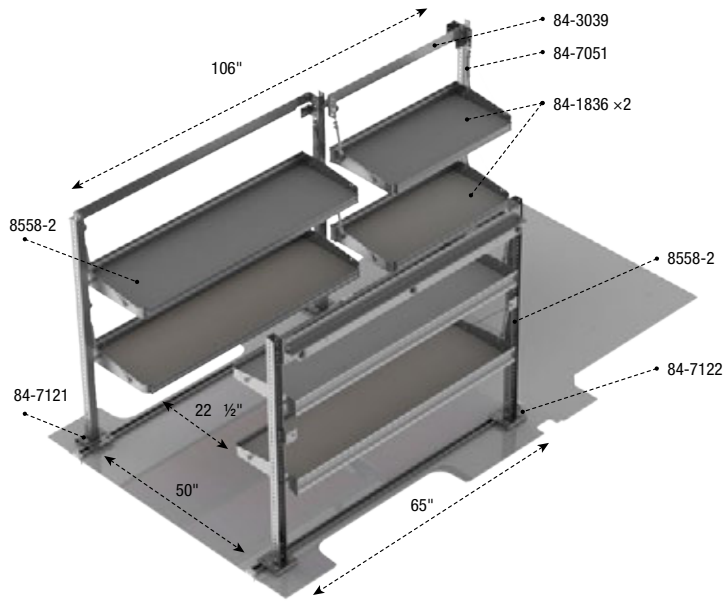

F219

Delivery Package

Aluminum

148"	177 lbs	6.8 hrs
Low	Yes	

Qty	Part #	Description
2	84-1836	Fold-Away Shelf Tray with Gas Shocks and Hardware
1	84-3039	Mounting Bar Assembly for Fold-Away Shelving
1	84-7051	Post Assembly for Fold-Away Shelving
1	84-7121	Fold-Away install kit, driver side
1	84-7122	Fold-Away install kit, passenger side
2	8558-2	Fold-Away Shelving

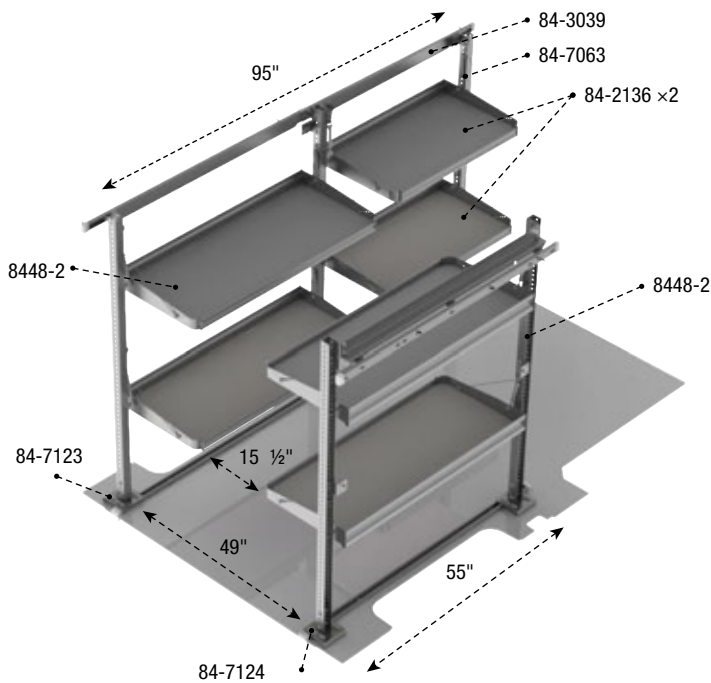

F319

Delivery Package

Aluminum

130"	176 lbs	6.8 hrs
Medium	Yes	

Qty	Part #	Description
2	84-2136	Fold-Away Shelf Tray with Gas Shocks and Hardware
1	84-3039	Mounting Bar Assembly for Fold-Away Shelving
1	84-7063	Post Assembly for Fold-Away Shelving
1	84-7123	Fold-Away install kit, driver side
1	84-7124	Fold-Away install kit, passenger side
2	8448-2	Fold-Away Shelving

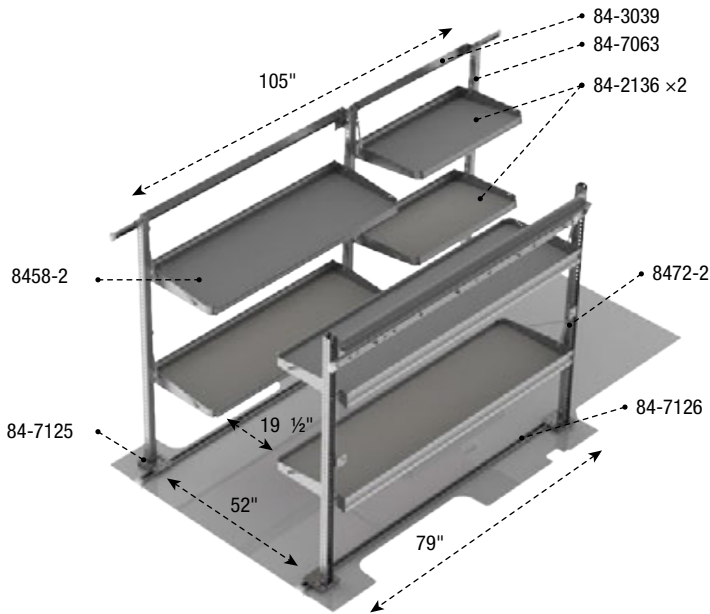

F419

Delivery Package

Aluminum

148"

198 lbs

6.8 hrs

Medium / High

Yes

Qty	Part #	Description
2	84-2136	Fold-Away Shelf Tray with Gas Shocks and Hardware
1	84-3039	Mounting Bar Assembly for Fold-Away Shelving
1	84-7063	Post Assembly for Fold-Away Shelving
1	84-7125	Fold-Away install kit, driver side
1	84-7126	Fold-Away install kit, passenger side
1	8458-2	Fold-Away Shelving
1	8472-2	Fold-Away Shelving

This package protrudes into the doorway by 6 inches.

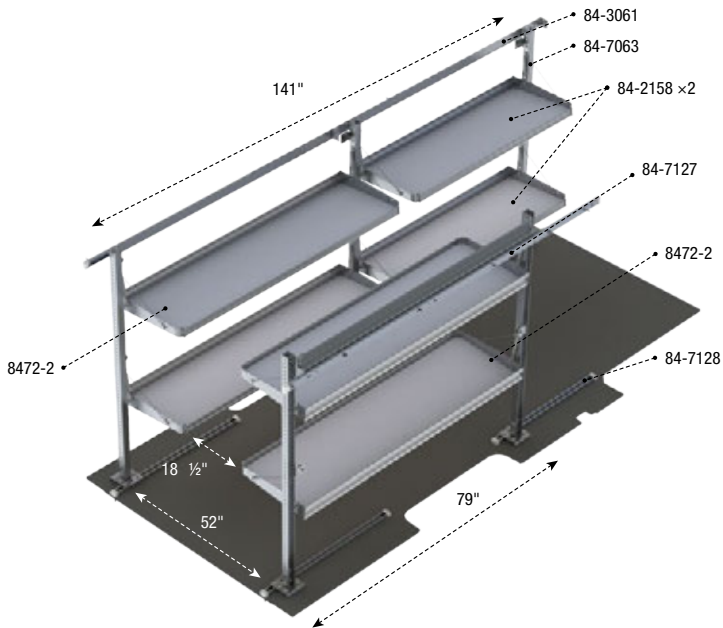

F519

Delivery Package

Aluminum

148" Ext

222 lbs

7.1 hrs

High

Yes

Qty	Part #	Description
2	84-2158	Fold-Away Shelf Tray with Gas Shocks and Hardware
1	84-3061	Mounting Bar Assembly for Fold-Away Shelving
1	84-7063	Post Assembly for Fold-Away Shelving
1	84-7127	Fold-Away install kit, driver side
1	84-7128	Fold-Away install kit, passenger side
2	8472-2	Fold-Away Shelving

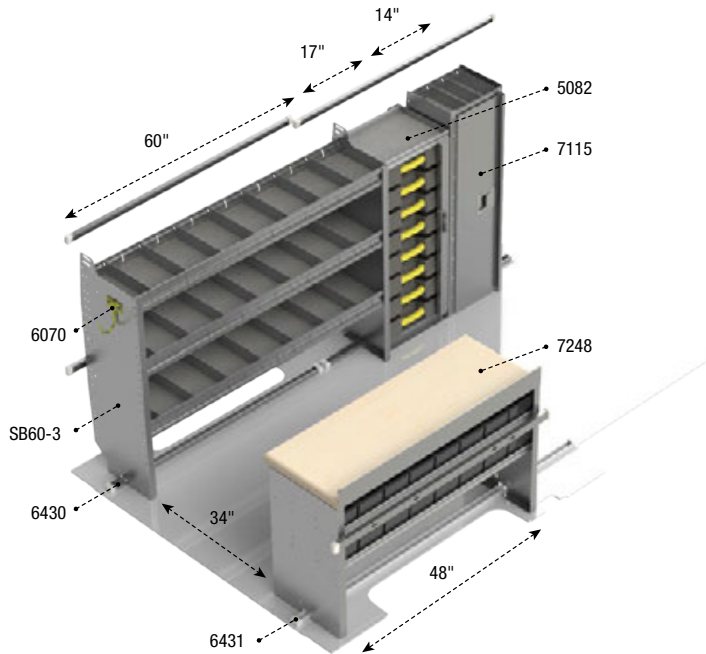

F111

Electrical Package

Aluminum

130"	227 lbs	4.5 hrs
Low	Yes	

Qty	Part #	Description
1	5082	Partskeeper cabinet with 8 carry cases
1	6070	6" Hook, 3" opening, painted
1	6430	Shelving install kit, driver side
1	6431	Shelving install kit, passenger side
1	7115	Locker w/top shelf
1	7248	Workbench w/hardwood top, 2 bin shelves
1	SB60-3	Contoured Shelving Unit with Dividers

PACKAGES

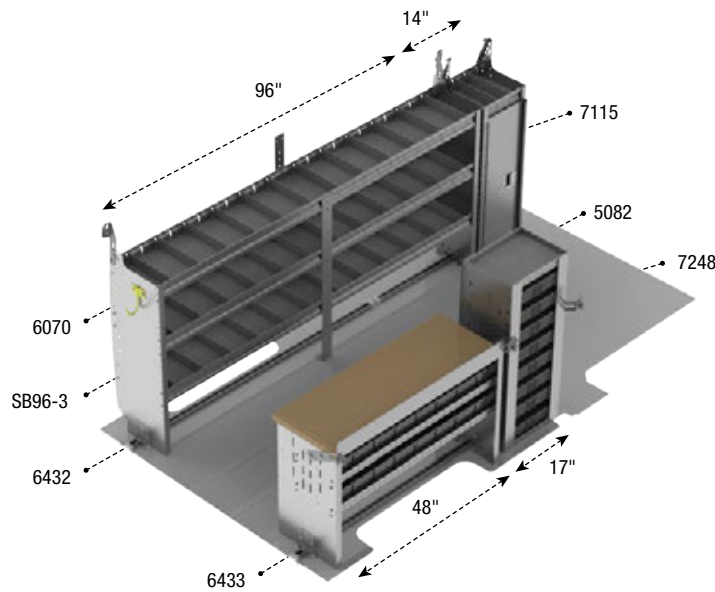

F211

Electrical Package

Aluminum

148"	256 lbs	4.7 hrs
Low	Yes	

Qty	Part #	Description
1	5082	Partskeeper cabinet with 8 carry cases
1	6070	6" Hook, 3" opening, painted
1	6432	Shelving install kit, driver side
1	6433	Shelving install kit, passenger side
1	7115	Locker w/top shelf
1	7248	Workbench w/hardwood top, 2 bin shelves
1	SB96-3	Contoured Shelving Unit with Dividers

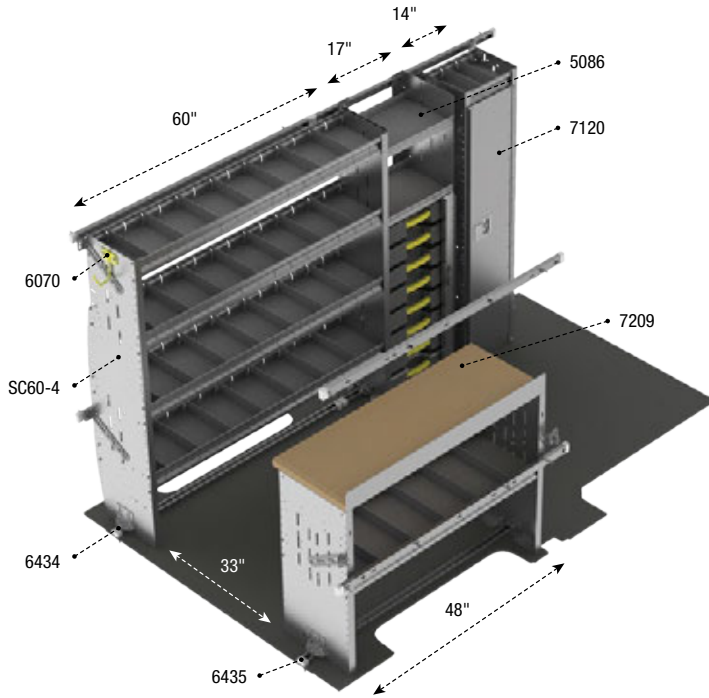

F311

Electrical Package

Aluminum

130"	239 lbs	5.1 hrs
Medium	Yes	

Qty	Part #	Description
1	5086	Partskeeper cabinet with 8 carry cases & 2 shelves
1	6070	6" Hook, 3" opening, painted
1	6434	Shelving install kit, driver side
1	6435	Shelving install kit, passenger side
1	7120	Locker w/top shelf
1	7209	Workbench w/hardwood top, 1 shelf
1	SC60-4	Contoured Shelving Unit with Dividers

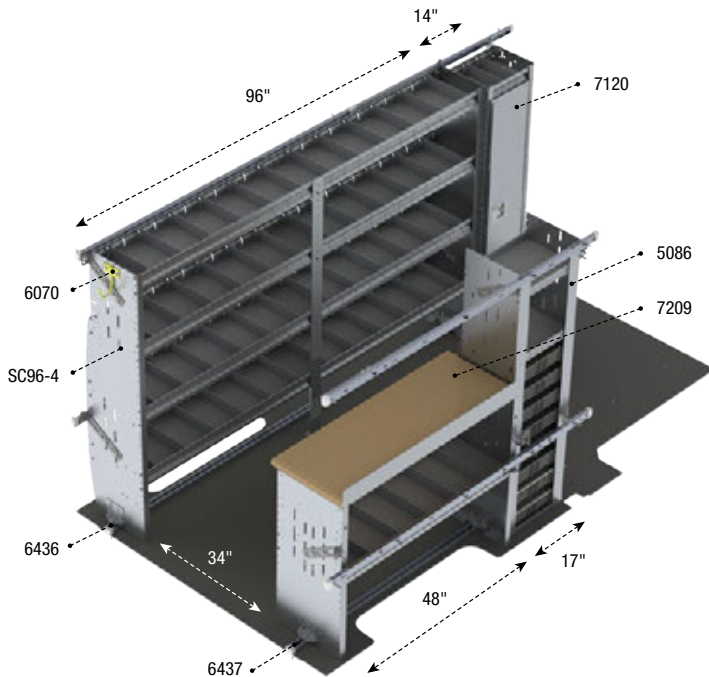

F411

Electrical Package

Aluminum

148"	271 lbs	5.3 hrs
Medium / High	Yes	

Qty	Part #	Description
1	5086	Partskeeper cabinet with 8 carry cases & 2 shelves
1	6070	6" Hook, 3" opening, painted
1	6436	Shelving install kit, driver side
1	6437	Shelving install kit, passenger side
1	7120	Locker w/top shelf
1	7209	Workbench w/hardwood top, 1 shelf
1	SC96-4	Contoured Shelving Unit with Dividers

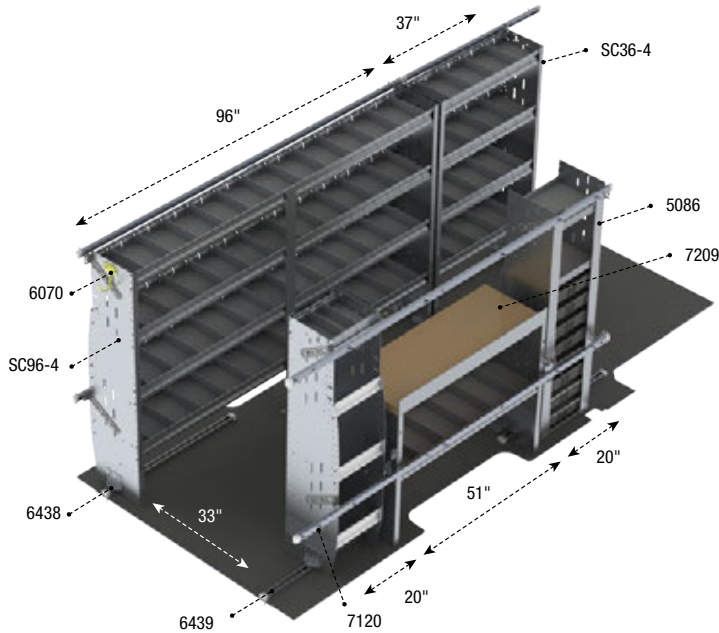

F511

Electrical Package

Aluminum

148" Ext	317 lbs	6.5 hrs
High	Yes	

Qty	Part #	Description
1	5086	Partskeeper cabinet with 8 carry cases & 2 shelves
1	6070	6" Hook, 3" opening, painted
1	6438	Shelving install kit, driver side
1	6439	Shelving install kit, passenger side
1	7120	Locker w/top shelf
1	7209	Workbench w/hardwood top, 1 shelf
1	SC36-4	Contoured Shelving Unit with Dividers
1	SC96-4	Contoured Shelving Unit with Dividers

PACKAGES

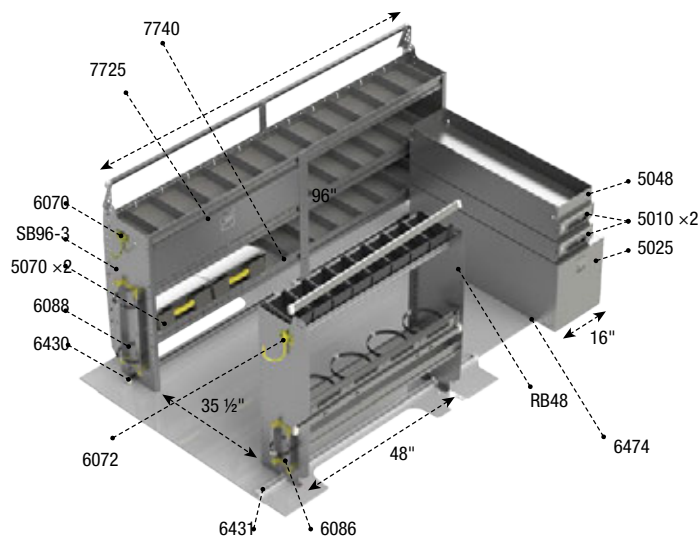

F112

HVAC Package

Aluminum

130"	296 lbs	7.5 hrs
Low	Yes	

Qty	Part #	Description
2	5010	Partslider drawer
1	5025	Jumbo tool drawer
1	5048	Top edge, for 5010 Partslider
2	5070	Partskeeper carry case with holder, universal
1	6070	6" Hook, 3" opening, painted
1	6072	8" Swivel Hook, 4" opening, painted
1	6086	Small aluminum bottle holder, with a black nylon strap
1	6088	Large aluminum bottle holder, with two black nylon straps
1	6430	Shelving install kit, driver side
1	6431	Shelving install kit, passenger side
1	6474	Jumbo drawer unit install kit
1	7725	Locking door kit
1	7740	Shelf Block
1	RB48	Contoured Refrigerant Bin Unit
1	SB96-3	Contoured Shelving Unit with Dividers

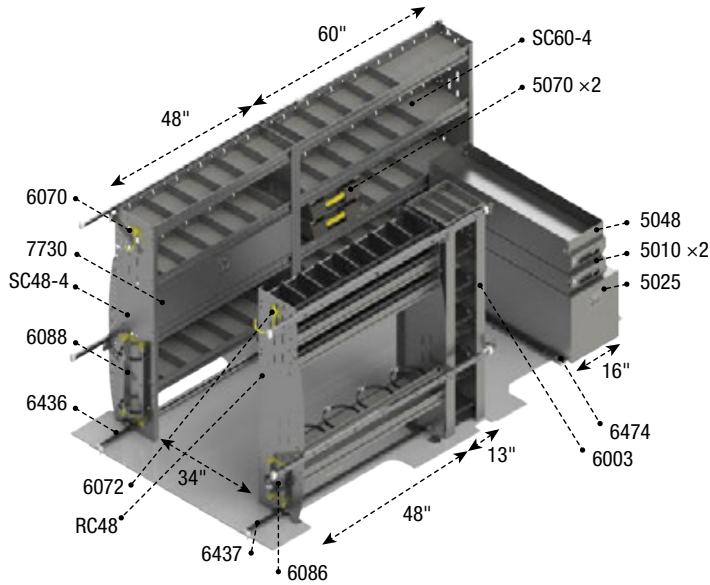

F412

HVAC Package

Aluminum



148"



432 lbs



9.5 hrs



Medium / High



Yes

Qty	Part #	Description
2	5010	Partslider drawer
1	5025	Jumbo tool drawer
1	5048	Top edge, for 5010 Partslider
2	5070	Partskeeper carry case with holder, universal
1	6003	5 Tier refrigerant rack for large bottles
1	6070	6" Hook, 3" opening, painted
1	6072	8" Swivel Hook, 4" opening, painted
1	6086	Small aluminum bottle holder, with a black nylon strap
1	6088	Large aluminum bottle holder, with two black nylon straps
1	6436	Shelving install kit, driver side
1	6437	Shelving install kit, passenger side
1	6474	Jumbo drawer unit install kit
1	7730	Locking door kit
1	RC48	Contoured Refrigerant Bin Unit
1	SC48-4	Contoured Shelving Unit with Dividers
1	SC60-4	Contoured Shelving Unit with Dividers

PACKAGES

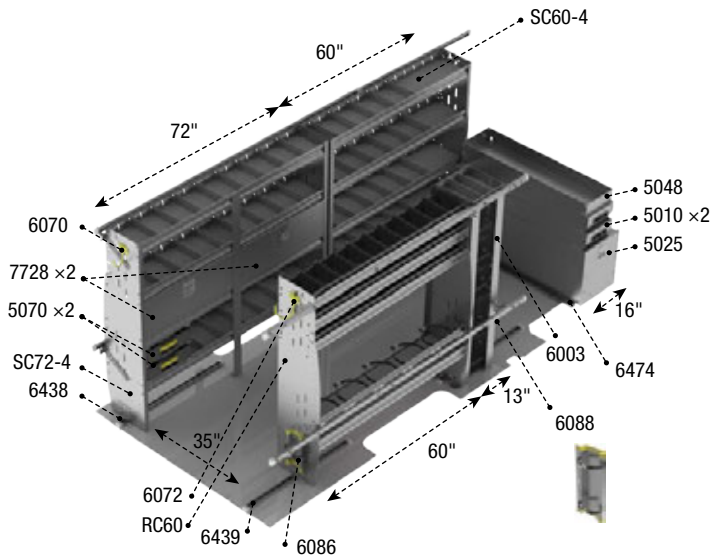

F512

HVAC Package

Aluminum



148" Ext



470 lbs



10.2 hrs



High



Yes

Qty	Part #	Description
2	5010	Partslider drawer
1	5025	Jumbo tool drawer
1	5048	Top edge, for 5010 Partslider
2	5070	Partskeeper carry case with holder, universal
1	6003	5 Tier refrigerant rack for large bottles
1	6070	6" Hook, 3" opening, painted
1	6072	8" Swivel Hook, 4" opening, painted
1	6086	Small aluminum bottle holder, with a black nylon strap
1	6088	Large aluminum bottle holder, with two black nylon straps
1	6438	Shelving install kit, driver side
1	6439	Shelving install kit, passenger side
1	6474	Jumbo drawer unit install kit
2	7728	Locking door kit
1	RC60	Contoured Refrigerant Bin Unit
1	SC60-4	Contoured Shelving Unit with Dividers
1	SC72-4	Contoured Shelving Unit with Dividers



Wheelbase



Roof Height



Weight



Estimated Install Time



Quickship



F412

HVAC Package

All layouts are designed to ensure that tools and equipment is safely and securely stored.



QUIET

The combination of the extrusion, shelf tray, and end-panels create durable, vibration-free shelves.



EFFICIENT

Ergonomic design reduces injuries and increases productivity.



TOUGH

Extrusion builds durability into shelf.

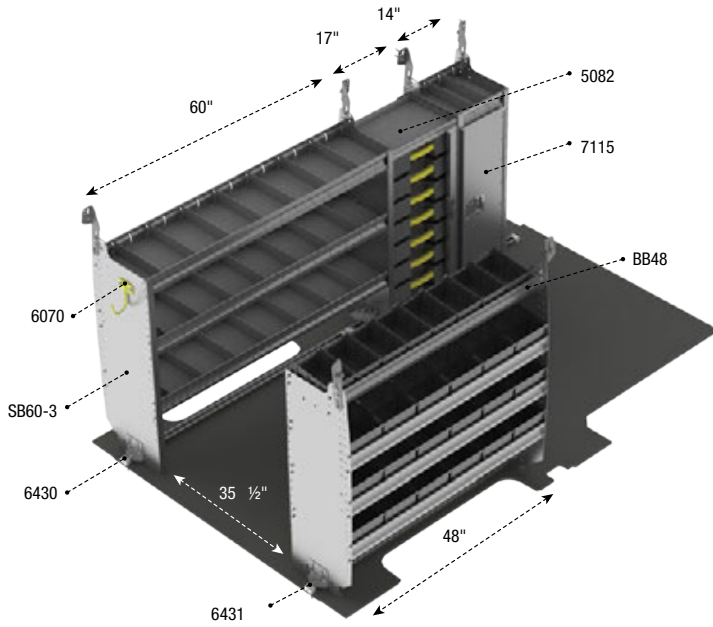

F116

Service Package

Aluminum

130"	233 lbs	4.5 hrs
Low	Yes	

Qty	Part #	Description
1	5082	Partskeeper cabinet with 8 carry cases
1	6070	6" Hook, 3" opening, painted
1	6430	Shelving install kit, driver side
1	6431	Shelving install kit, passenger side
1	7115	Locker w/top shelf
1	BB48	Contoured Bin Shelving Unit
1	SB60-3	Contoured Shelving Unit with Dividers

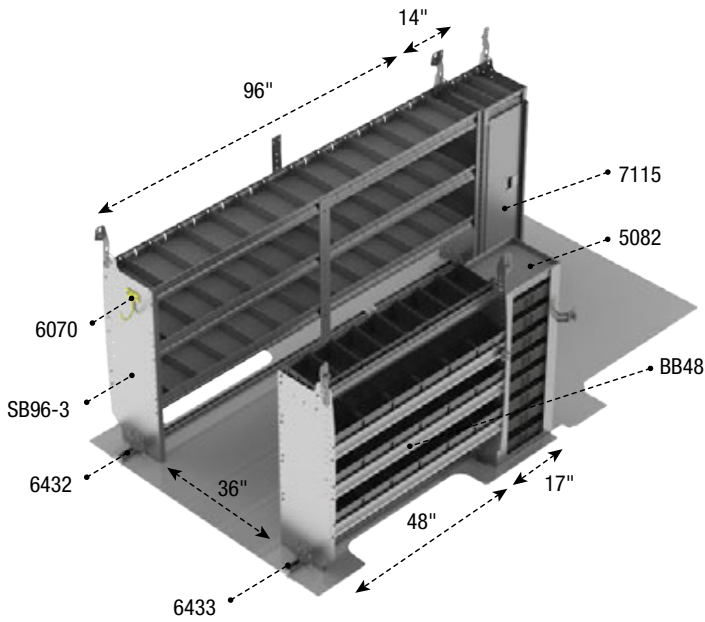

F216

Service Package

Aluminum

148"	262 lbs	4.7 hrs
Low	Yes	

Qty	Part #	Description
1	5082	Partskeeper cabinet with 8 carry cases
1	6070	6" Hook, 3" opening, painted
1	6432	Shelving install kit, driver side
1	6433	Shelving install kit, passenger side
1	7115	Locker w/top shelf
1	BB48	Contoured Bin Shelving Unit
1	SB96-3	Contoured Shelving Unit with Dividers

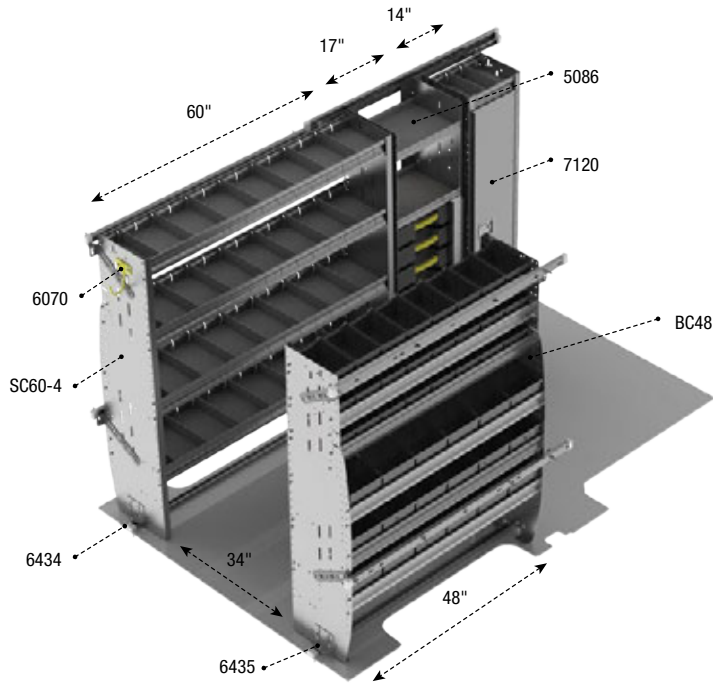

F316

Service Package

Aluminum

130"	278 lbs	5.5 hrs
Medium	Yes	

Qty	Part #	Description
1	5086	Partskeeper cabinet with 8 carry cases & 2 shelves
1	6070	6" Hook, 3" opening, painted
1	6434	Shelving install kit, driver side
1	6435	Shelving install kit, passenger side
1	7120	Locker w/top shelf
1	BC48	Contoured Bin Shelving Unit
1	SC60-4	Contoured Shelving Unit with Dividers

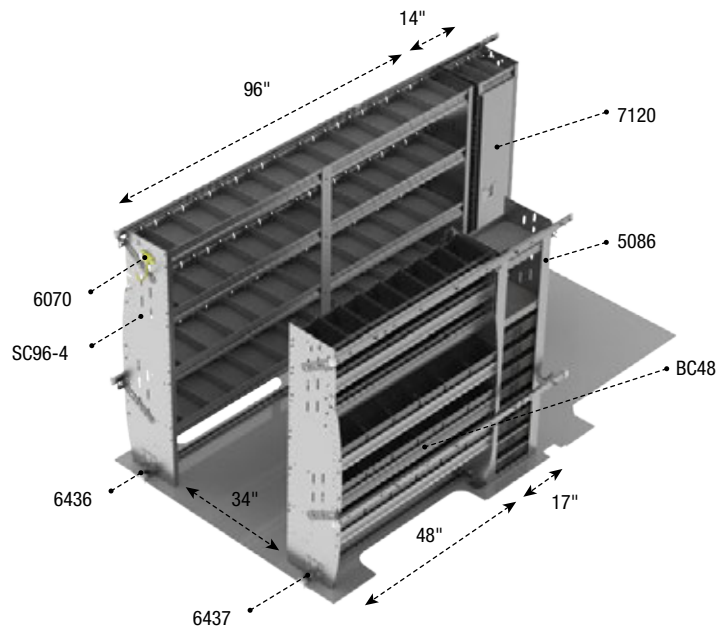

F416

Service Package

Aluminum

148"	310 lbs	5.7 hrs
Medium / High	Yes	

Qty	Part #	Description
1	5086	Partskeeper cabinet with 8 carry cases & 2 shelves
1	6070	6" Hook, 3" opening, painted
1	6436	Shelving install kit, driver side
1	6437	Shelving install kit, passenger side
1	7120	Locker w/top shelf
1	BC48	Contoured Bin Shelving Unit
1	SC96-4	Contoured Shelving Unit with Dividers



Z16-F4

Service Package

All layouts are designed to ensure that tools and equipment is safely and securely stored.

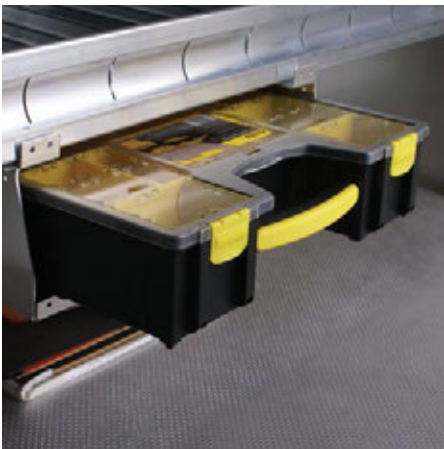

QUIET
The combination of the extrusion, shelf tray, and end-panels create durable, vibration-free shelves.



EFFICIENT
Ergonomic design reduces injuries and increases productivity.



TOUGH
Extrusion builds durability into shelf.

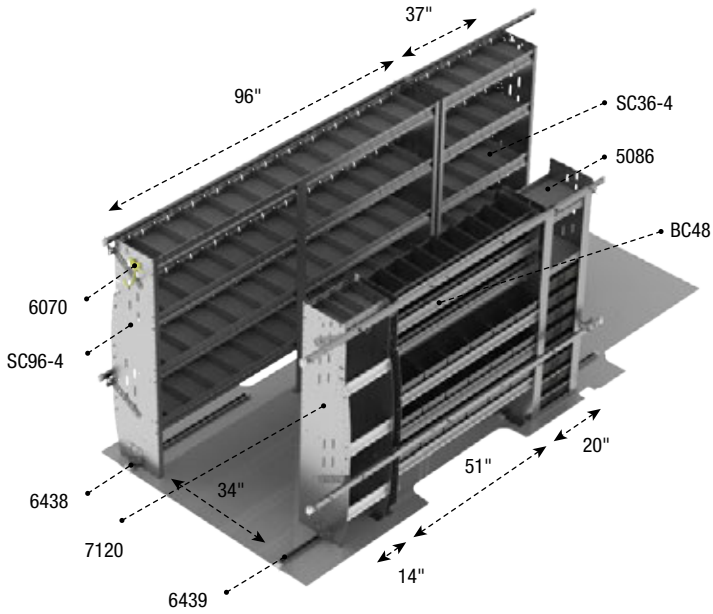

F516

Service Package

Aluminum

148" Ext

356 lbs

6.9 hrs

High

Yes

Qty	Part #	Description
1	5086	Partskeeper cabinet with 8 carry cases & 2 shelves
1	6070	6" Hook, 3" opening, painted
1	6438	Shelving install kit, driver side
1	6439	Shelving install kit, passenger side
1	7120	Locker w/top shelf
1	BC48	Contoured Bin Shelving Unit
1	SC36-4	Contoured Shelving Unit with Dividers
1	SC96-4	Contoured Shelving Unit with Dividers

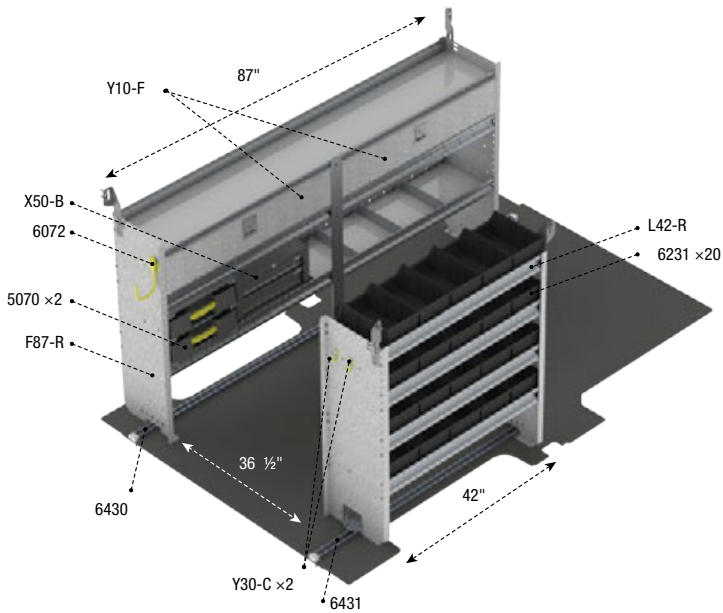

Z16-F1

Service Package

Steel

130"

283 lbs

5 hrs

Low

Yes

Qty	Part #	Description
2	5070	Partskeeper carry case with holder, universal
1	6072	8" Swivel Hook, 4" opening, painted
20	6231	Large Bin, Graphite
1	6430	Shelving install kit, driver side
1	6431	Shelving install kit, passenger side
1	F87-R	Square Back Shelving Unit with Dividers
1	L42-R	Square Back Shelving Unit
1	X50-B	Compact 2-Drawer Unit
2	Y10-F	Locking door kit
2	Y30-C	Coat Hook, 1" opening, chrome plated

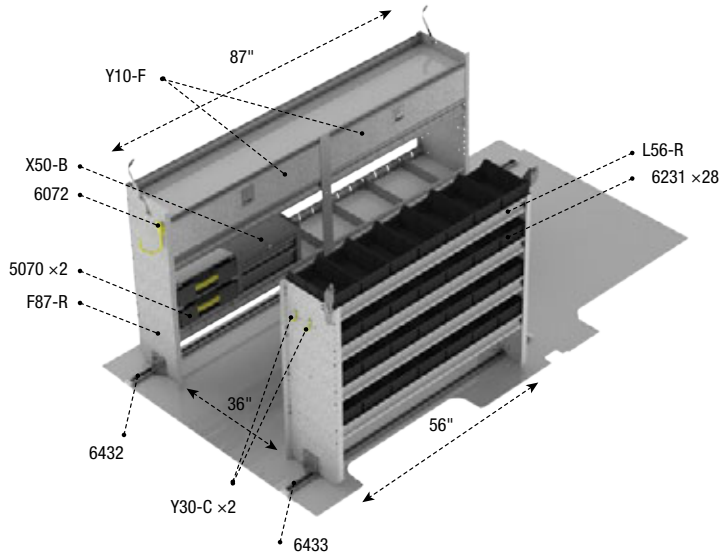

Z16-F2

Service Package

Steel

148"

307 lbs

5 hrs

Low

Yes

Qty	Part #	Description
2	5070	Partskeeper carry case with holder, universal
1	6072	8" Swivel Hook, 4" opening, painted
28	6231	Large Bin, Graphite
1	6432	Shelving install kit, driver side
1	6433	Shelving install kit, passenger side
1	F87-R	Square Back Shelving Unit with Dividers
1	L56-R	Square Back Shelving Unit
1	X50-B	Compact 2-Drawer Unit
2	Y10-F	Locking door kit
2	Y30-C	Coat Hook, 1" opening, chrome plated

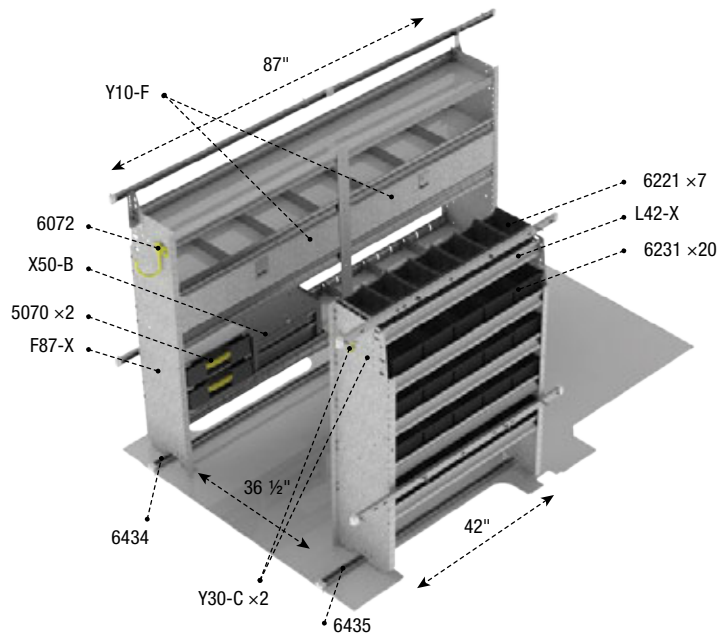

Z16-F3

Service Package

Steel

130"

311 lbs

5.2 hrs

Medium

Yes

Qty	Part #	Description
2	5070	Partskeeper carry case with holder, universal
1	6072	8" Swivel Hook, 4" opening, painted
7	6221	Medium Bin, Graphite
20	6231	Large Bin, Graphite
1	6434	Shelving install kit, driver side
1	6435	Shelving install kit, passenger side
1	F87-X	Square Back Shelving Unit with Dividers
1	L42-X	Square Back Shelving Unit
1	X50-B	Compact 2-Drawer Unit
2	Y10-F	Locking door kit
2	Y30-C	Coat Hook, 1" opening, chrome plated

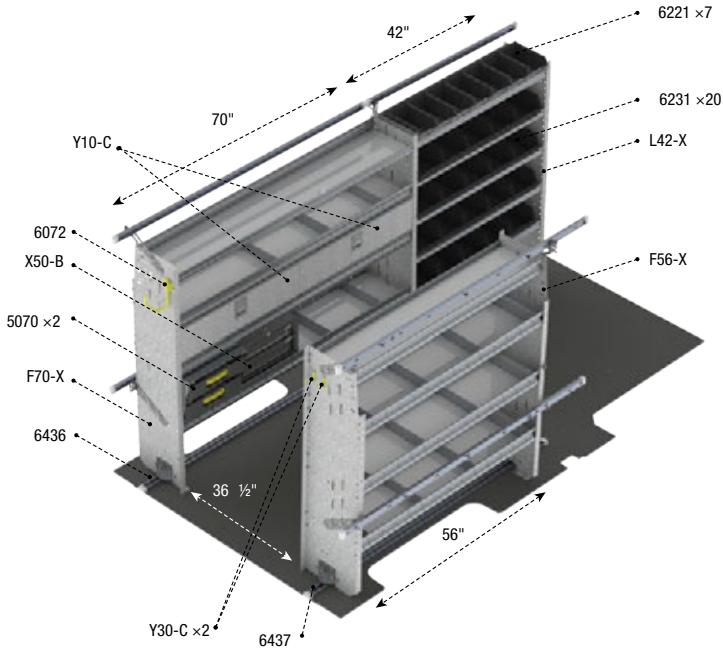

Z16-F4

Service Package

Steel



148"



370 lbs



6.2 hrs



Medium / High



Yes

Qty	Part #	Description
2	5070	Partskeeper carry case with holder, universal
1	6072	8" Swivel Hook, 4" opening, painted
7	6221	Medium Bin, Graphite
20	6231	Large Bin, Graphite
1	6436	Shelving install kit, driver side
1	6437	Shelving install kit, passenger side
1	F56-X	Square Back Shelving Unit with Dividers
1	F70-X	Square Back Shelving Unit with Dividers
1	L42-X	Square Back Shelving Unit
1	X50-B	Compact 2-Drawer Unit
2	Y10-C	Locking door kit
2	Y30-C	Coat Hook, 1" opening, chrome plated

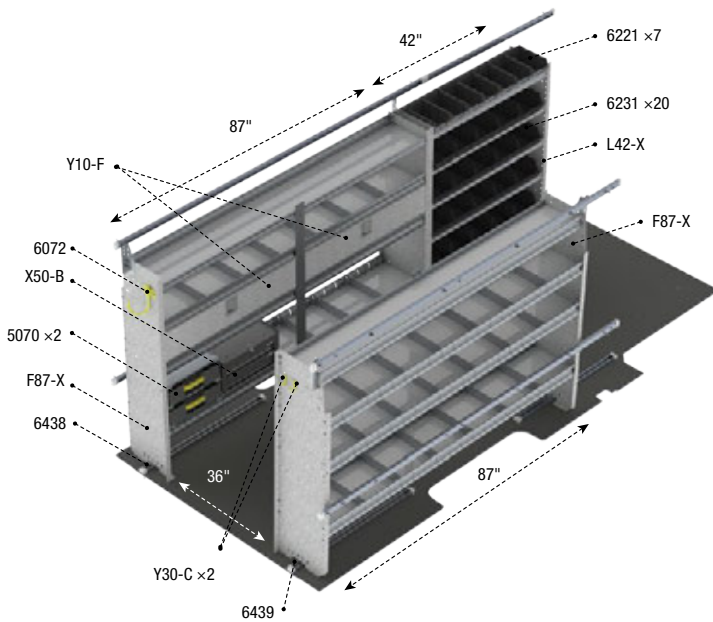

Z16-F5

Service Package

Steel



148" Ext



436 lbs



6.2 hrs



High



Yes

Qty	Part #	Description
2	5070	Partskeeper carry case with holder, universal
1	6072	8" Swivel Hook, 4" opening, painted
7	6221	Medium Bin, Graphite
20	6231	Large Bin, Graphite
1	6438	Shelving install kit, driver side
1	6439	Shelving install kit, passenger side
2	F87-X	Square Back Shelving Unit with Dividers
1	L42-X	Square Back Shelving Unit
1	X50-B	Compact 2-Drawer Unit
2	Y10-F	Locking door kit
2	Y30-C	Coat Hook, 1" opening, chrome plated

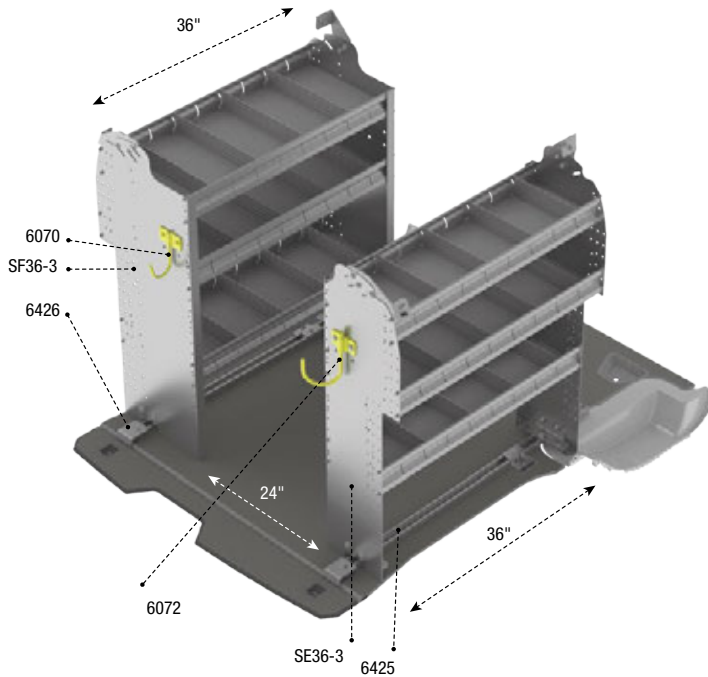

C410

Contractor Package

Aluminum

105"	73 lbs	2.4 hrs
Standard	Yes	

Qty	Part #	Description
1	6070	6" Hook, 3" opening, painted
1	6072	8" Swivel Hook, 4" opening, painted
1	6425	Shelving install kit, passenger side
1	6426	Shelving install kit, driver side
1	SE36-3	Contoured Shelving Unit with Dividers
1	SF36-3	Contoured Shelving Unit with Dividers

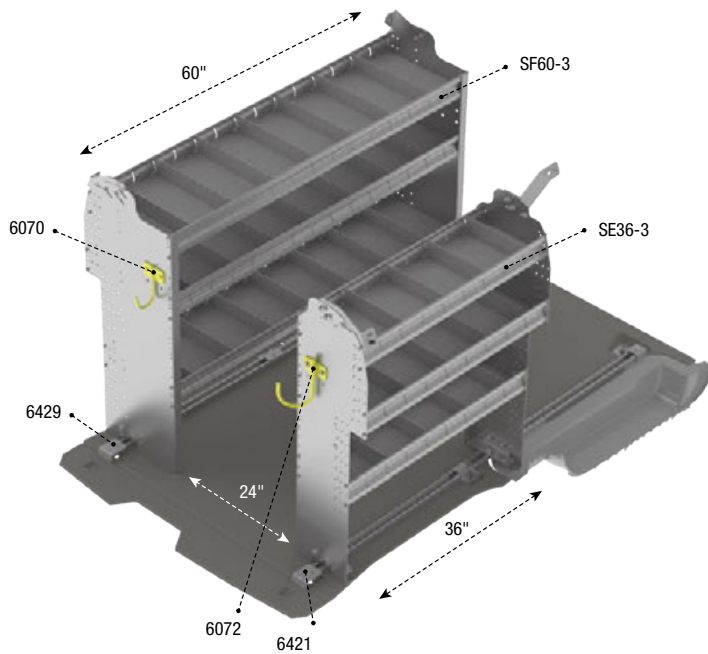

C510

Contractor Package

Aluminum

120.5"	89 lbs	2.4 hrs
Standard	Yes	

Qty	Part #	Description
1	6070	6" Hook, 3" opening, painted
1	6072	8" Swivel Hook, 4" opening, painted
1	6421	Shelving install kit, passenger side
1	6429	Shelving install kit, driver side
1	SE36-3	Contoured Shelving Unit with Dividers
1	SF60-3	Contoured Shelving Unit with Dividers



C511

Electrical Package

Work more safely and efficiently with a well-organized layout.



QUIET

The combination of the extrusion, shelf tray, and end-panels create durable, vibration-free shelves.



EFFICIENT

Ergonomic design reduces injuries and increases productivity.



TOUGH

Extrusion builds durability into shelf.

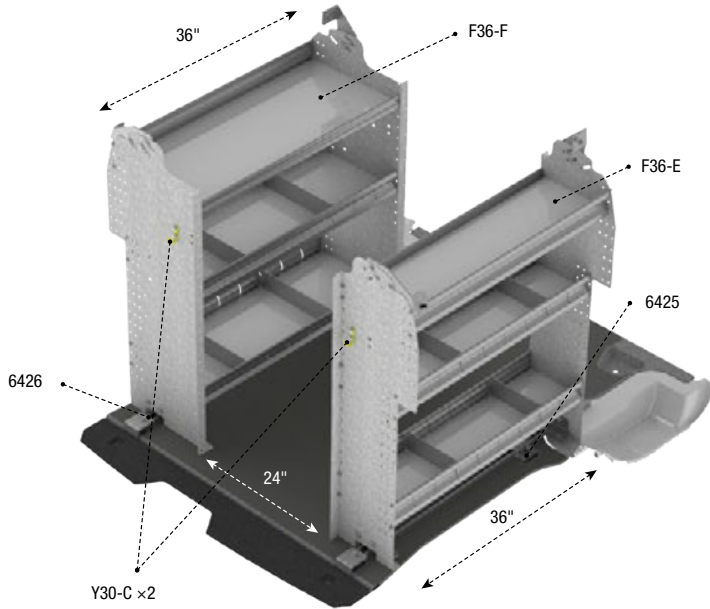

Z10-C4

Base Contractor Package

Steel

105"	107 lbs	2.4 hrs
Standard	Yes	

Qty	Part #	Description
1	6425	Shelving install kit, passenger side
1	6426	Shelving install kit, driver side
1	F36-E	Contoured Shelving Unit with Dividers
1	F36-F	Contoured Shelving Unit with Dividers
2	Y30-C	Coat Hook, 1" opening, chrome plated

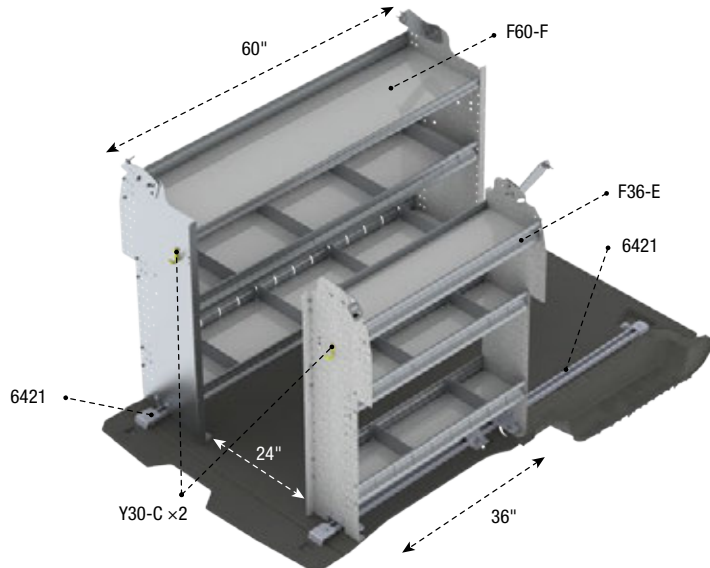

Z10-C5

Base Contractor Package

Steel

120.5"	126 lbs	2.4 hrs
Standard	Yes	

Qty	Part #	Description
1	6421	Shelving install kit, passenger side
1	6429	Shelving install kit, driver side
1	F36-E	Contoured Shelving Unit with Dividers
1	F60-F	Contoured Shelving Unit with Dividers
2	Y30-C	Coat Hook, 1" opening, chrome plated

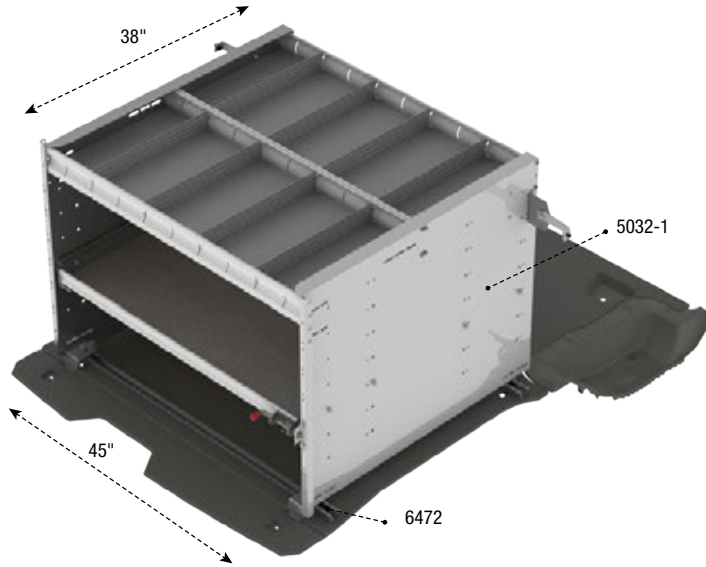

C419

Delivery Package

Aluminum

105", 120.5"	89 lbs	1 hr
Standard	Yes	

Qty	Part #	Description
1	5032-1	Axess Tray with 1 shelf / 1 drawer
1	6472	Axess Tray install kit

PACKAGES

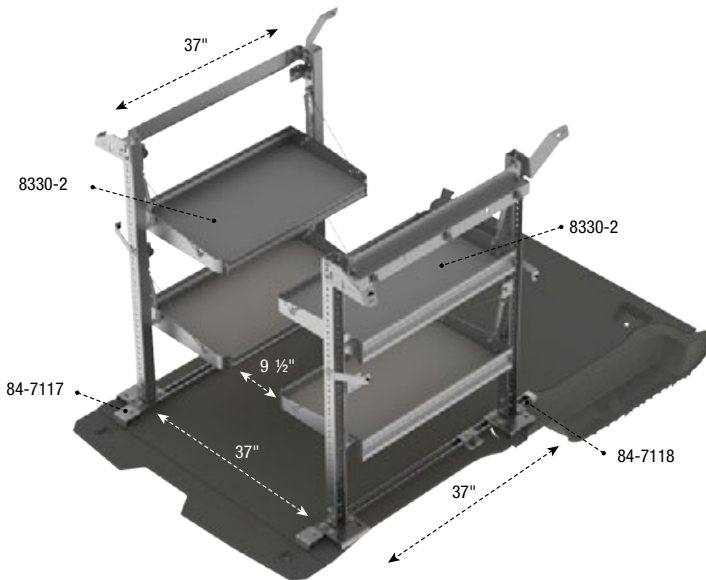

C519

Delivery Package

Aluminum

120.5"	90 lbs	2.6 hrs
Standard	Yes	

Qty	Part #	Description
2	8330-2	Fold-Away Shelving
1	84-7117	Fold-Away install kit, driver side
1	84-7118	Fold-Away install kit, passenger side

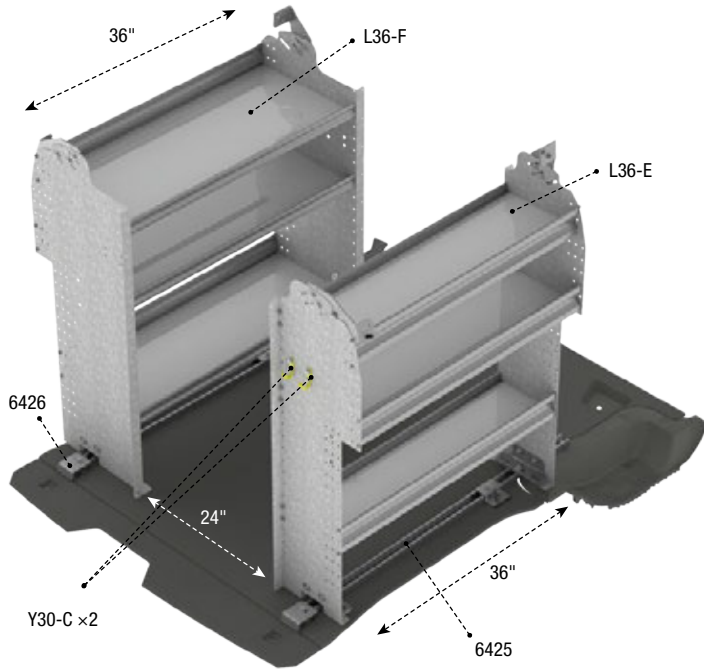

Z19-C4

Delivery Package

Steel

105"	122 lbs	2.4 hrs
Standard	Yes	

Qty	Part #	Description
1	6425	Shelving install kit, passenger side
1	6426	Shelving install kit, driver side
1	L36-E	Contoured Shelving Unit
1	L36-F	Contoured Shelving Unit
2	Y30-C	Coat Hook, 1" opening, chrome plated

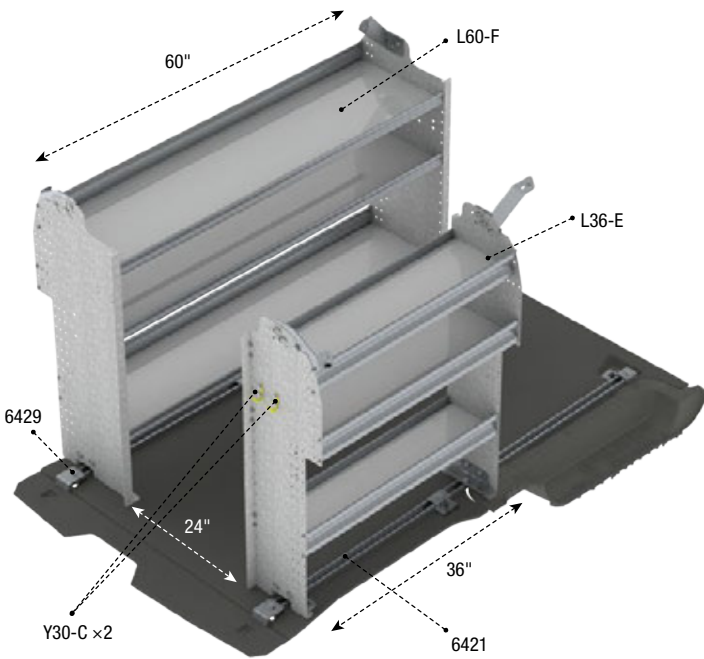

Z19-C5

Delivery Package

Steel

120.5"	143 lbs	2.4 hrs
Standard	Yes	

Qty	Part #	Description
1	6421	Shelving install kit, passenger side
1	6429	Shelving install kit, driver side
1	L36-E	Contoured Shelving Unit
1	L60-F	Contoured Shelving Unit
2	Y30-C	Coat Hook, 1" opening, chrome plated

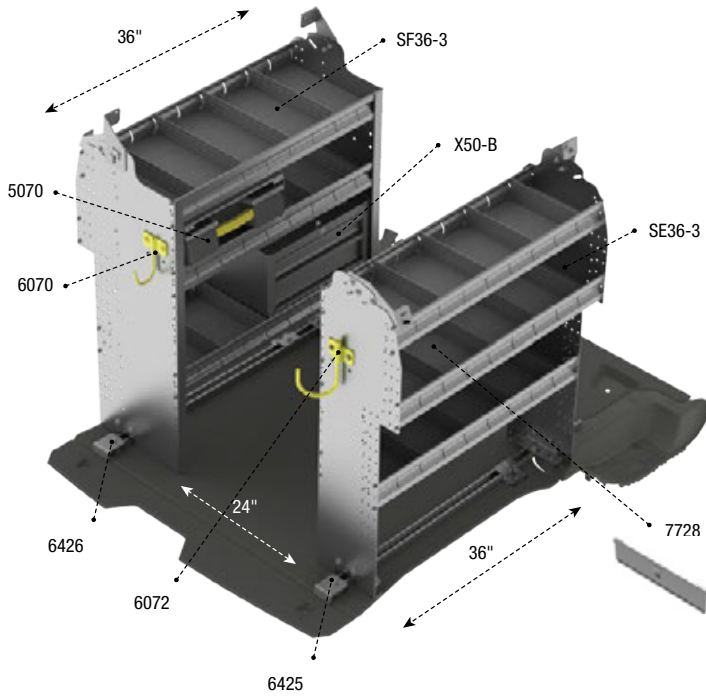

C411

Electrical Package

Aluminum

105"	105 lbs	3.5 hrs
Standard	Yes	

Qty	Part #	Description
1	5070	Partskeeper carry case with holder, universal
1	6070	6" Hook, 3" opening, painted
1	6072	8" Swivel Hook, 4" opening, painted
1	6425	Shelving install kit, passenger side
1	6426	Shelving install kit, driver side
1	7728	Locking door kit
1	SE36-3	Contoured Shelving Unit with Dividers
1	SF36-3	Contoured Shelving Unit with Dividers
1	X50-B	Compact 2-Drawer Unit

PACKAGES

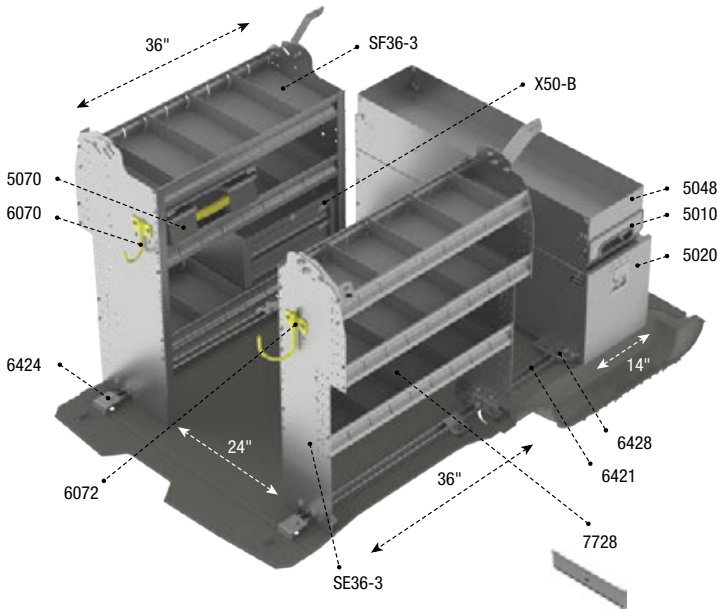

C511

Electrical Package

Aluminum

120.5"	186 lbs	5.2 hrs
Standard	Yes	

Qty	Part #	Description
1	5010	Partslider drawer
1	5020	Tool drawer
1	5048	Top edge, for 5010 Partslider
1	5070	Partskeeper carry case with holder, universal
1	6070	6" Hook, 3" opening, painted
1	6072	8" Swivel Hook, 4" opening, painted
1	6421	Shelving install kit, passenger side
1	6424	Shelving install kit, driver side
1	6428	5020 Tool drawer install kit
1	7728	Locking door kit
1	SE36-3	Contoured Shelving Unit with Dividers
1	SF36-3	Contoured Shelving Unit with Dividers
1	X50-B	Compact 2-Drawer Unit

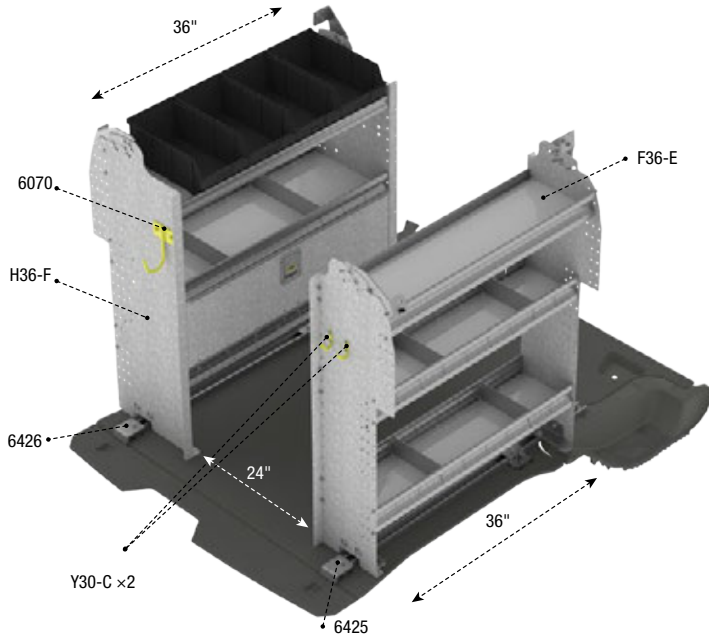

Z11-C4

Electrical Package

Steel

105"	116 lbs	2.6 hrs
Standard	Yes	

Qty	Part #	Description
1	6070	6" Hook, 3" opening, painted
1	6425	Shelving install kit, passenger side
1	6426	Shelving install kit, driver side
1	F36-E	Contoured Shelving Unit with Dividers
1	H36-F	Contoured Bin Shelving Unit
2	Y30-C	Coat Hook, 1" opening, chrome plated

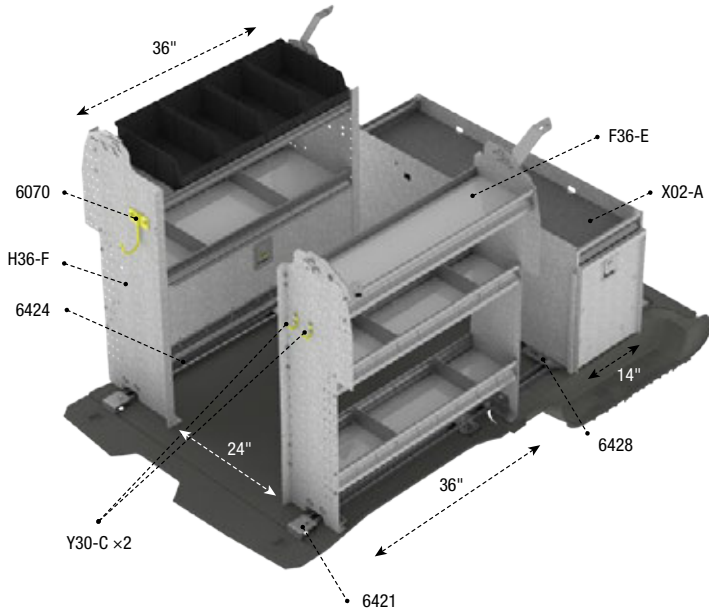

Z11-C5

Electrical Package

Steel

120.5"	196 lbs	3.6 hrs
Standard	Yes	

Qty	Part #	Description
1	6070	6" Hook, 3" opening, painted
1	6421	Shelving install kit, passenger side
1	6424	Shelving install kit, driver side
1	6428	5020 Tool drawer install kit
1	F36-E	Contoured Shelving Unit with Dividers
1	H36-F	Contoured Bin Shelving Unit
1	X02-A	Fleetline Tool Drawer
2	Y30-C	Coat Hook, 1" opening, chrome plated

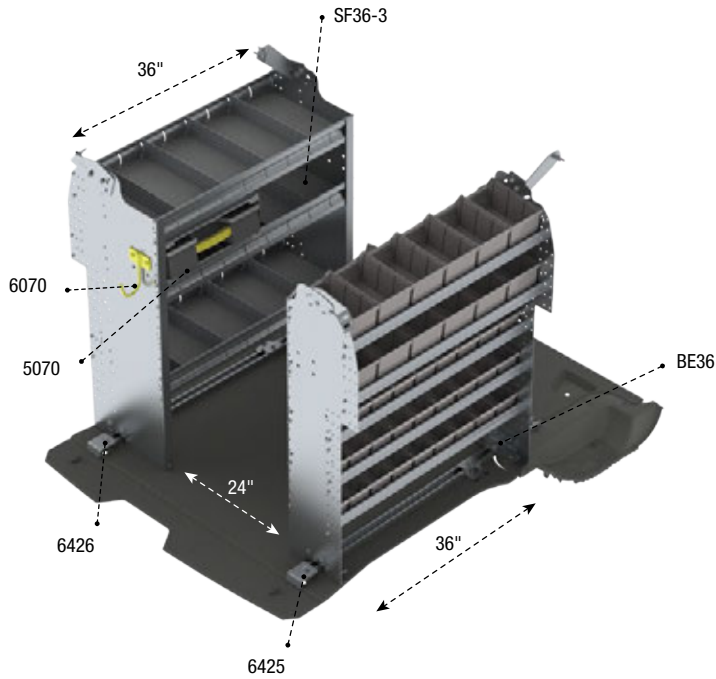

C416

Service Package

Aluminum

105"	92 lbs	2.5 hrs
Standard	Yes	

Qty	Part #	Description
1	5070	Partskeeper carry case with holder, universal
1	6070	6" Hook, 3" opening, painted
1	6425	Shelving install kit, passenger side
1	6426	Shelving install kit, driver side
1	BE36	Contoured Bin Shelving Unit
1	SF36-3	Contoured Shelving Unit with Dividers

PACKAGES

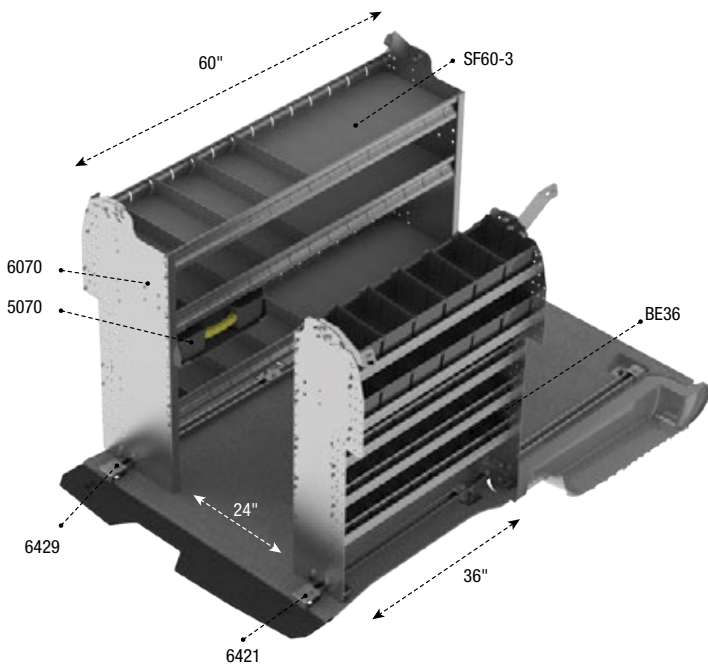

C516

Service Package

Aluminum

120.5"	108 lbs	2.5 hrs
Standard	Yes	

Qty	Part #	Description
1	5070	Partskeeper carry case with holder, universal
1	6070	6" Hook, 3" opening, painted
1	6421	Shelving install kit, passenger side
1	6429	Shelving install kit, driver side
1	BE36	Contoured Bin Shelving Unit
1	SF60-3	Contoured Shelving Unit with Dividers

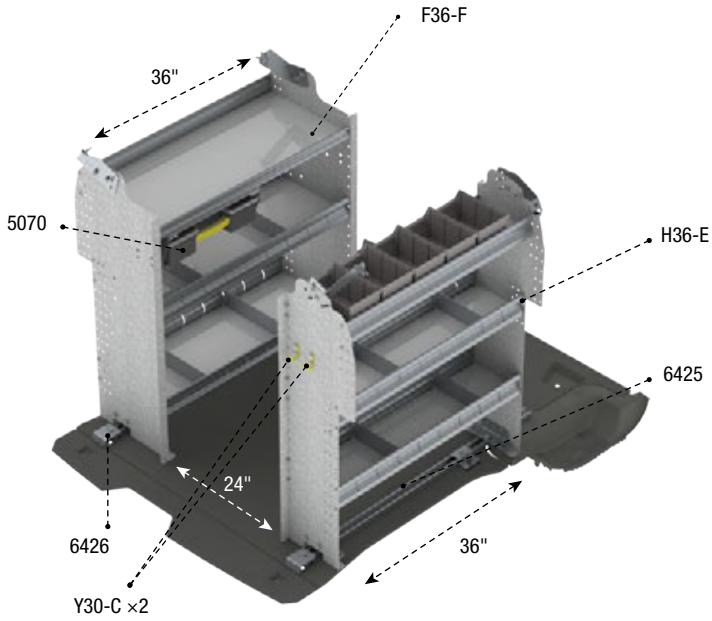

Z16-C4

Service Package

Steel

105"	122 lbs	2.7 hrs
Standard	Yes	

Qty	Part #	Description
1	5070	Partskeeper carry case with holder, universal
1	6425	Shelving install kit, passenger side
1	6426	Shelving install kit, driver side
1	F36-F	Contoured Shelving Unit with Dividers
1	H36-E	Contoured Bin Shelving Unit
2	Y30-C	Coat Hook, 1" opening, chrome plated

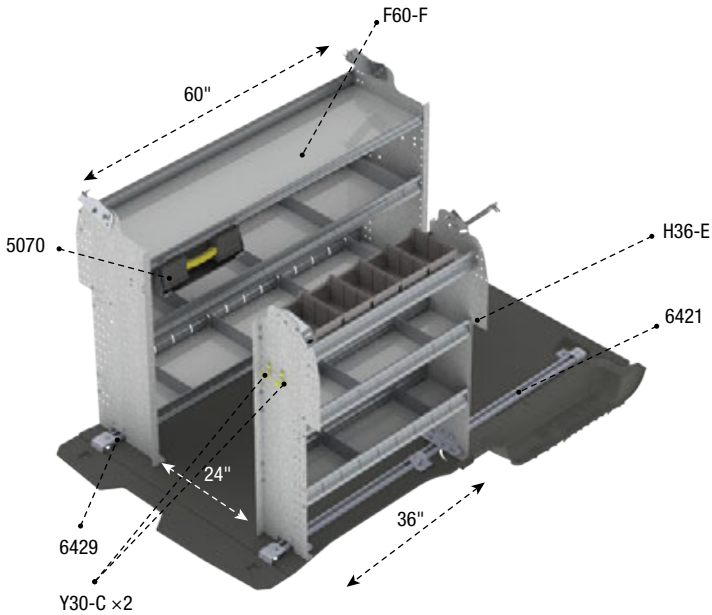

Z16-C5

Service Package

Steel

120.5"	141 lbs	2.7 hrs
Standard	Yes	

Qty	Part #	Description
1	5070	Partskeeper carry case with holder, universal
1	6421	Shelving install kit, passenger side
1	6429	Shelving install kit, driver side
1	F60-F	Contoured Shelving Unit with Dividers
1	H36-E	Contoured Bin Shelving Unit
2	Y30-C	Coat Hook, 1" opening, chrome plated

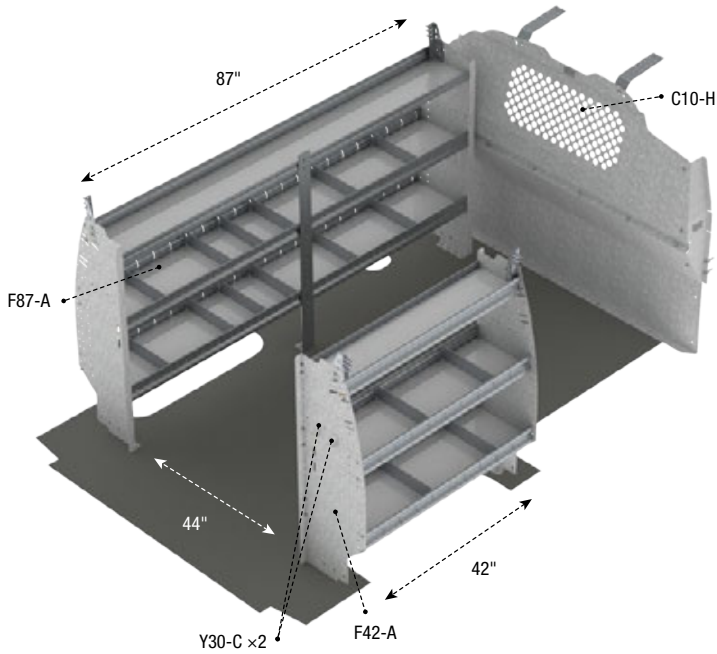

Z05-H

Base Contractor Package

Steel

135", 155"	204 lbs	3.4 hrs
Standard	Yes	

Qty	Part #	Description
1	C10-H	Contoured Safety Partition with Perforated Window
1	F42-A	Contoured Shelving Unit with Dividers
1	F87-A	Contoured Shelving Unit with Dividers
2	Y30-C	Coat Hook, 1" opening, chrome plated

PACKAGES

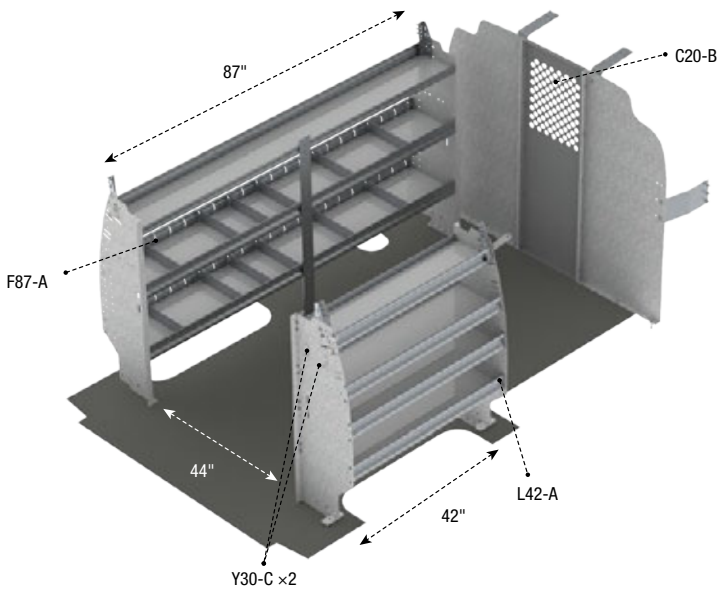

Z10-H

Base Contractor Package

Steel

135", 155"	215 lbs	3.4 hrs
Standard	No	

Qty	Part #	Description
1	C20-B	Straight Partition with Perforated Window, No Access
1	F87-A	Contoured Shelving Unit with Dividers
1	L42-A	Contoured Shelving Unit
2	Y30-C	Coat Hook, 1" opening, chrome plated

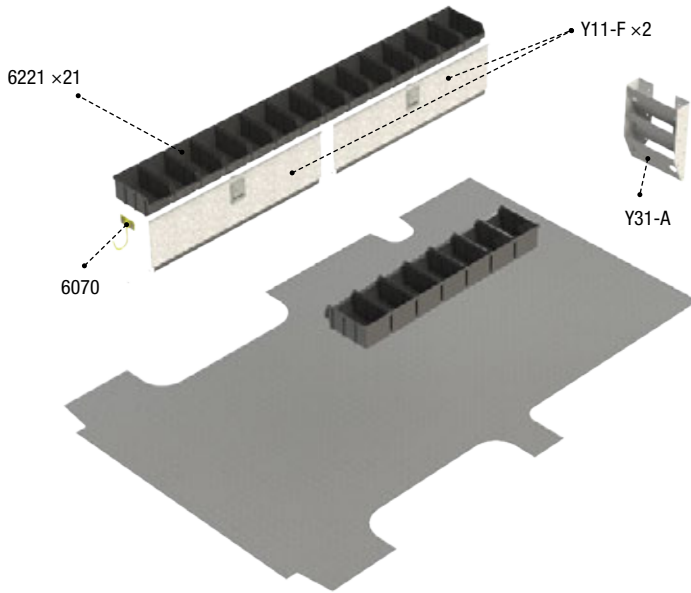

Z30-H

Contractor Package

Steel

135", 155"	47 lbs	1.4 hrs
Standard	Yes	

Qty	Part #	Description
1	6070	6" Hook, 3" opening, painted
21	6221	Medium Bin, Graphite
2	Y11-F	Locking door kit
1	Y31-A	Paper Holder, extra deep, 3 slots

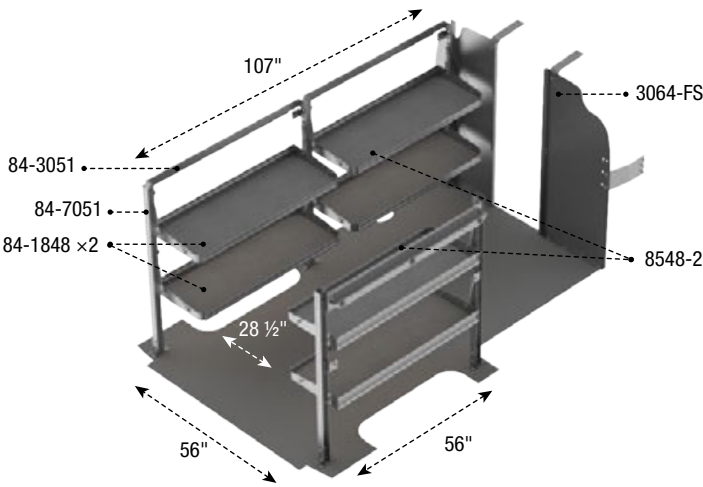

A019

Extended Length Delivery Package

Aluminum

155"	180 lbs	7.6 hrs
Standard	No	

Qty	Part #	Description
1	3064-FS	Straight Walk Through Partition
2	84-1848	Fold-Away Shelf Tray with Gas Shocks and Hardware
1	84-3051	Mounting Bar Assembly for Fold-Away Shelving
1	84-7051	Post Assembly for Fold-Away Shelving
2	8548-2	Fold-Away Shelving

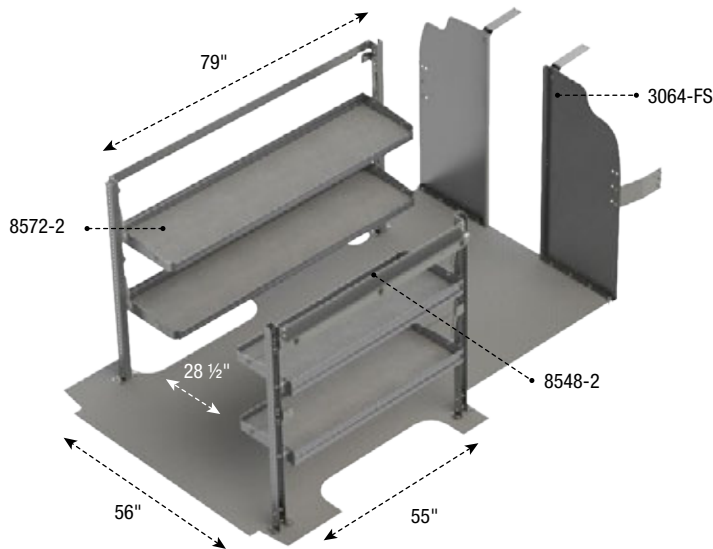

A119

Delivery Package

Aluminum

135", 155"

152 lbs

5.6 hrs

Standard

No

Qty	Part #	Description
1	3064-FS	Straight Walk Through Partition
1	8548-2	Fold-Away Shelving
1	8572-2	Fold-Away Shelving

PACKAGES

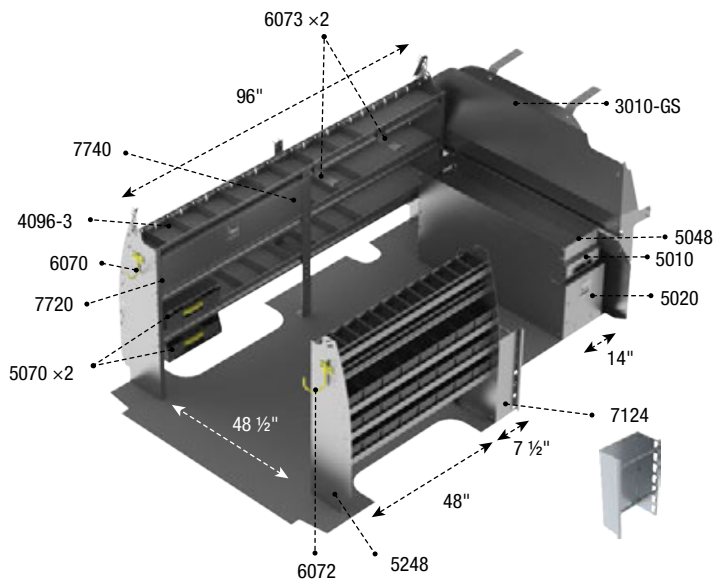

A011

Deluxe Electrical Package

Aluminum

135", 155"

298 lbs

7.2 hrs

Standard

No

Qty	Part #	Description
1	3010-GS	Contoured Safety Partition
1	4096-3	Contoured Shelving Unit with Dividers
1	5010	Partslider drawer
1	5020	Tool drawer
1	5048	Top edge, for 5010 Partslider
2	5070	Partskeeper carry case with holder, universal
1	5248	Contoured Bin Shelving Unit
1	6070	6" Hook, 3" opening, painted
1	6072	8" Swivel Hook, 4" opening, painted
2	6073	Large aluminum movable hook, 6.5" opening
1	7124	Reel Holder with two 5/8" diameter rods
1	7720	Locking door kit
1	7740	Shelf Block

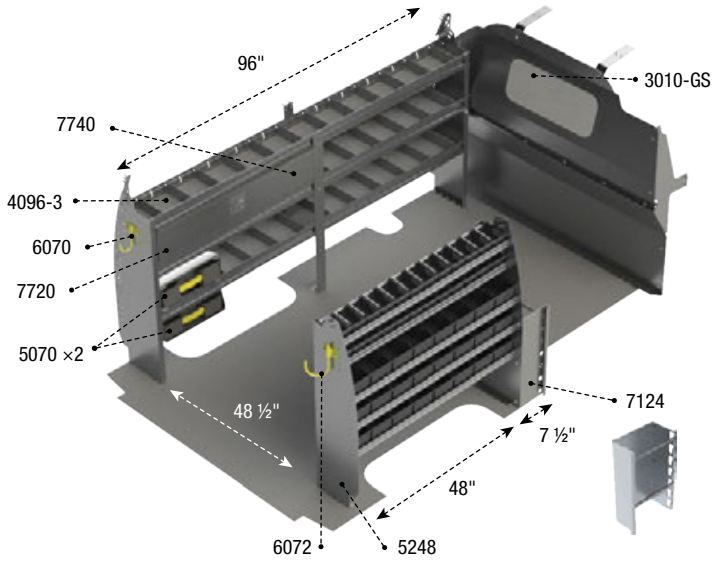

A111

Base Electrical Package

Aluminum

135", 155"

215 lbs

5.5 hrs

Standard

No

Qty	Part #	Description
1	3010-GS	Contoured Safety Partition
1	4096-3	Contoured Shelving Unit with Dividers
2	5070	Partskeeper carry case with holder, universal
1	5248	Contoured Bin Shelving Unit
1	6070	6" Hook, 3" opening, painted
1	6072	8" Swivel Hook, 4" opening, painted
1	7124	Reel Holder with two 5/8" diameter rods
1	7720	Locking door kit
1	7740	Shelf Block

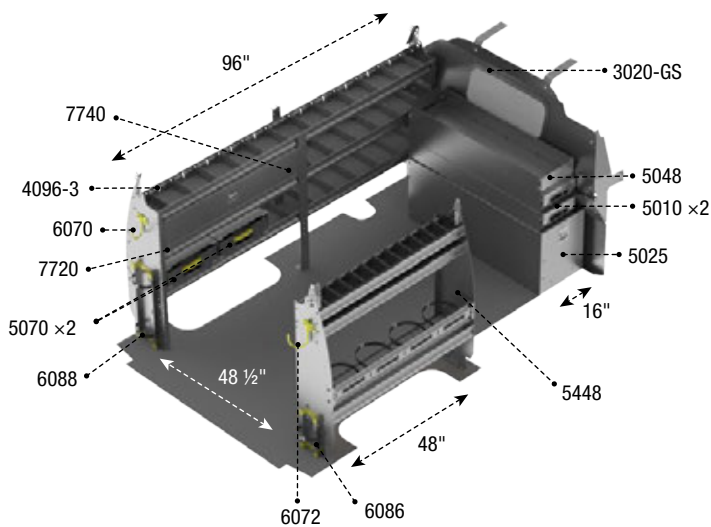

A012

Deluxe HVAC Package

Aluminum

135", 155"

323 lbs

7.6 hrs

Standard

No

Qty	Part #	Description
1	3020-GS	Contoured Safety Partition with Tempered Glass Window
1	4096-3	Contoured Shelving Unit with Dividers
2	5010	Partslider drawer
1	5025	Jumbo tool drawer
1	5048	Top edge, for 5010 Partslider
2	5070	Partskeeper carry case with holder, universal
1	5448	Contoured Refrigerant Bin Unit
1	6070	6" Hook, 3" opening, painted
1	6072	8" Swivel Hook, 4" opening, painted
1	6086	Small aluminum bottle holder, with a black nylon strap
1	6088	Large aluminum bottle holder, with two black nylon straps
1	7720	Locking door kit
1	7740	Shelf Block

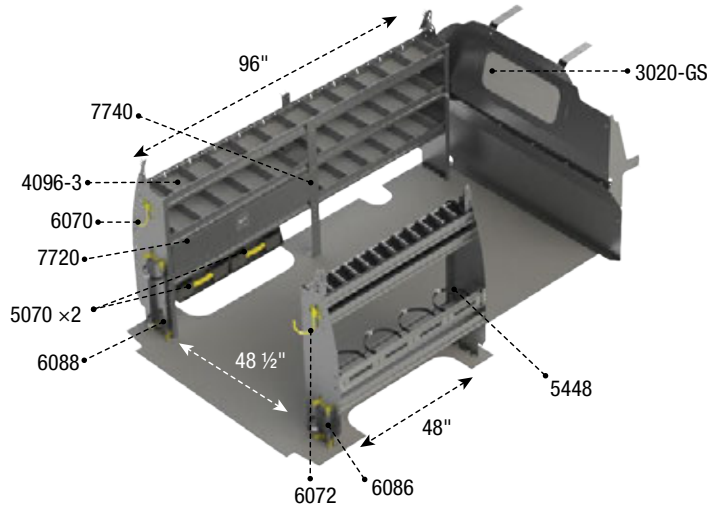

A112

Base HVAC Package

Aluminum

135", 155"	197 lbs	5.4 hrs
Standard	No	

Qty	Part #	Description
1	3020-GS	Contoured Safety Partition with Tempered Glass Window
1	4096-3	Contoured Shelving Unit with Dividers
2	5070	Partskeeper carry case with holder, universal
1	5448	Contoured Refrigerant Bin Unit
1	6070	6" Hook, 3" opening, painted
1	6072	8" Swivel Hook, 4" opening, painted
1	6086	Small aluminum bottle holder, with a black nylon strap
1	6088	Large aluminum bottle holder, with two black nylon straps
1	7720	Locking door kit
1	7740	Shelf Block

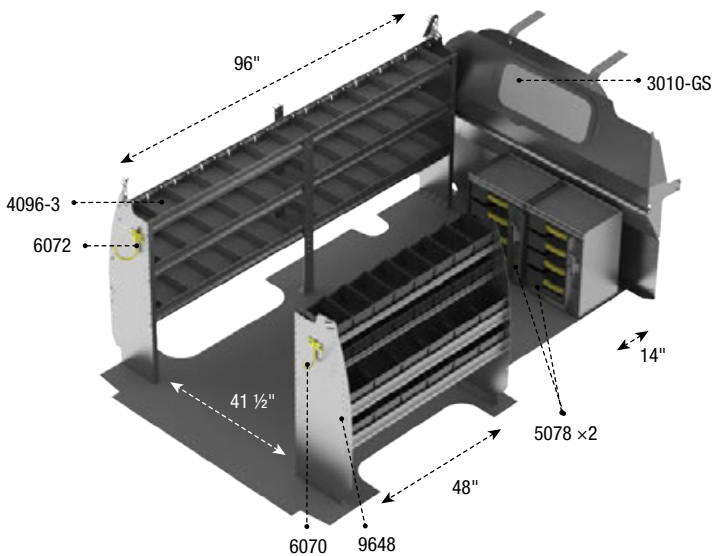

A015

Deluxe Plumber Package

Aluminum

135", 155"	234 lbs	4 hrs
Standard	Yes	

Qty	Part #	Description
1	3010-GS	Contoured Safety Partition
1	4096-3	Contoured Shelving Unit with Dividers
2	5078	Partskeeper cabinet with 4 carry cases
1	6070	6" Hook, 3" opening, painted
1	6072	8" Swivel Hook, 4" opening, painted
1	9648	Contoured Bin Shelving Unit

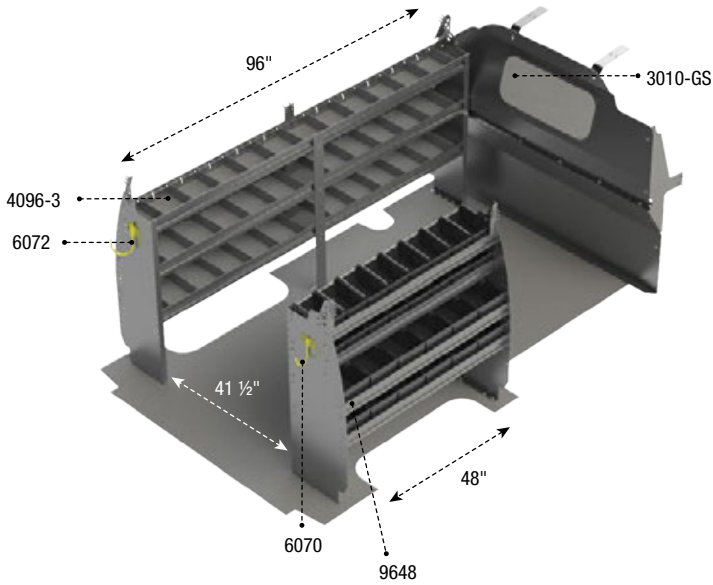

A115

Base Plumber Package

Aluminum

135", 155"	188 lbs	3.4 hrs
Standard	Yes	

Qty	Part #	Description
1	3010-GS	Contoured Safety Partition
1	4096-3	Contoured Shelving Unit with Dividers
1	6070	6" Hook, 3" opening, painted
1	6072	8" Swivel Hook, 4" opening, painted
1	9648	Contoured Bin Shelving Unit

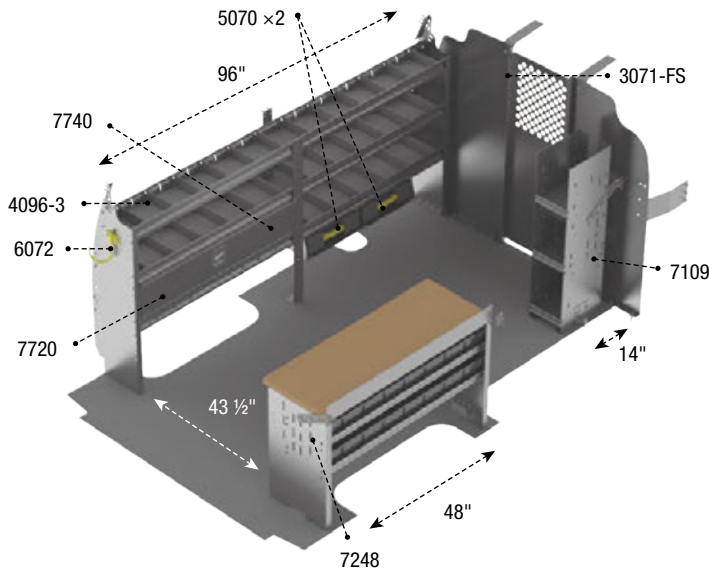

A016

Deluxe Service Package

Aluminum

135", 155"	242 lbs	5.6 hrs
Standard	No	

Qty	Part #	Description
1	3071-FS	Straight Partition with Perforated Window, Swing Door
1	4096-3	Contoured Shelving Unit with Dividers
2	5070	Partskeeper carry case with holder, universal
1	6072	8" Swivel Hook, 4" opening, painted
1	7109	Bookshelf
1	7248	Workbench w/hardwood top, 2 bin shelves
1	7720	Locking door kit
1	7740	Shelf Block

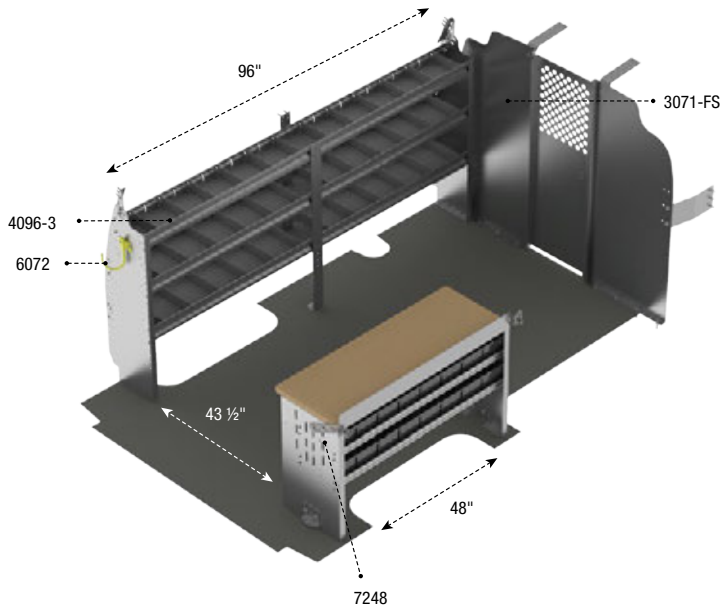

A116

Base Service Package

Aluminum

135", 155"	200 lbs	3.6 hrs
Standard	No	

Qty	Part #	Description
1	3071-FS	Straight Partition with Perforated Window, Swing Door
1	4096-3	Contoured Shelving Unit with Dividers
1	6072	8" Swivel Hook, 4" opening, painted
1	7248	Workbench w/hardwood top, 2 bin shelves

PACKAGES

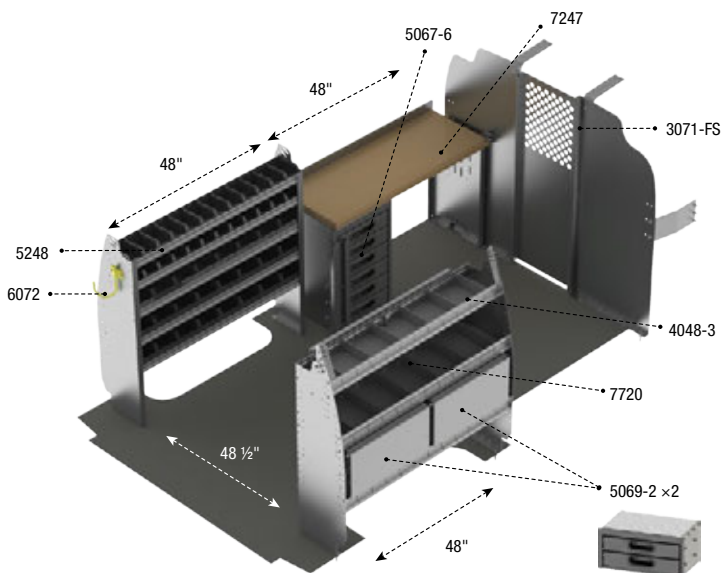

A017

Deluxe WorkStation Package

Aluminum

135", 155"	433 lbs	6.4 hrs
Standard	No	

Qty	Part #	Description
1	3071-FS	Straight Partition with Perforated Window, Swing Door
1	4048-3	Contoured Shelving Unit with Dividers
1	5067-6	6 Drawer cabinet
2	5069-2	2 Drawer cabinet
1	5248	Contoured Bin Shelving Unit
1	6072	8" Swivel Hook, 4" opening, painted
1	7247	Workbench w/hardwood top, one end panel
1	7720	Locking door kit

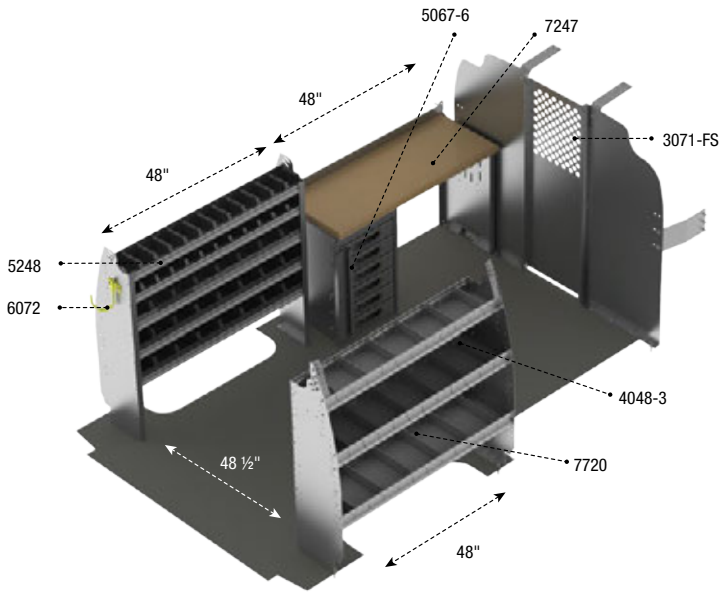

A117

Base WorkStation Package

Aluminum

135", 155"

303 lbs

5.4 hrs

Standard

No

Qty	Part #	Description
1	3071-FS	Straight Partition with Perforated Window, Swing Door
1	4048-3	Contoured Shelving Unit with Dividers
1	5067-6	6 Drawer cabinet
1	5248	Contoured Bin Shelving Unit
1	6072	8" Swivel Hook, 4" opening, painted
1	7247	Workbench w/hardwood top, one end panel
1	7720	Locking door kit



A011 Deluxe Electrical Package

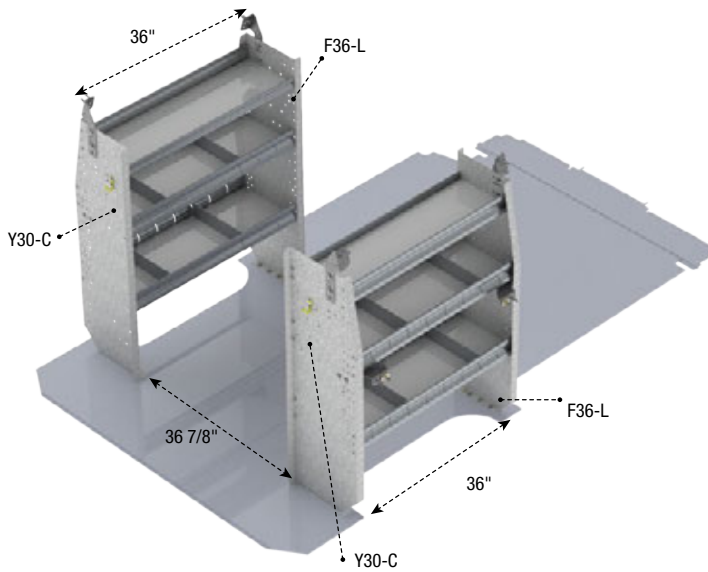

Z10-M0

Base Contractor Package

Steel

126"	92 lbs	2.4 hrs
Standard	Yes	

Qty	Part #	Description
2	F36-L	Contoured Shelving Unit with Dividers
2	Y30-C	Coat Hook, 1" opening, chrome plated

PACKAGES

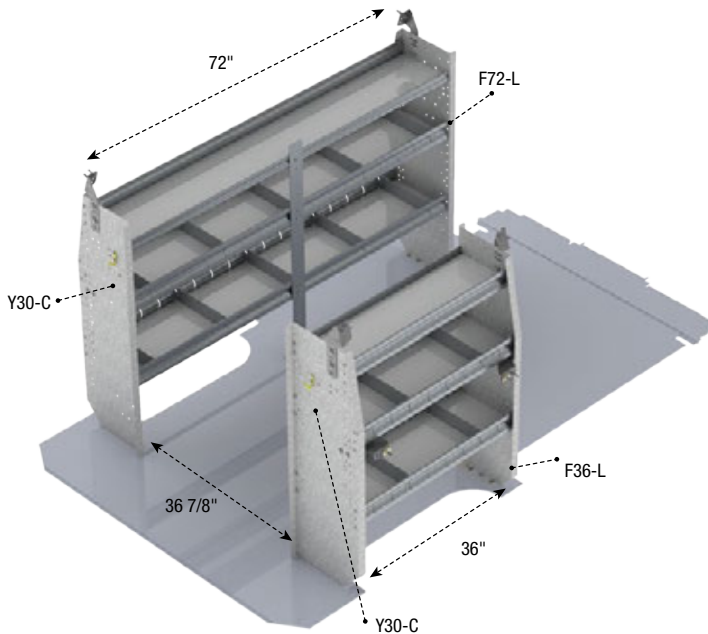

Z10-M1

Deluxe Contractor Package

Steel

126"	113 lbs	2.4 hrs
Standard	Yes	

Qty	Part #	Description
1	F36-L	Contoured Shelving Unit with Dividers
1	F72-L	Contoured Shelving Unit with Dividers
2	Y30-C	Coat Hook, 1" opening, chrome plated



M111

Electrical Package

Engineered design increases storage and improves cargo capacity.



QUIET

The combination of the extrusion, shelf tray, and end-panels create durable, vibration-free shelves.



EFFICIENT

Ergonomic design reduces injuries and increases productivity.



TOUGH

Extrusion builds durability into shelf.

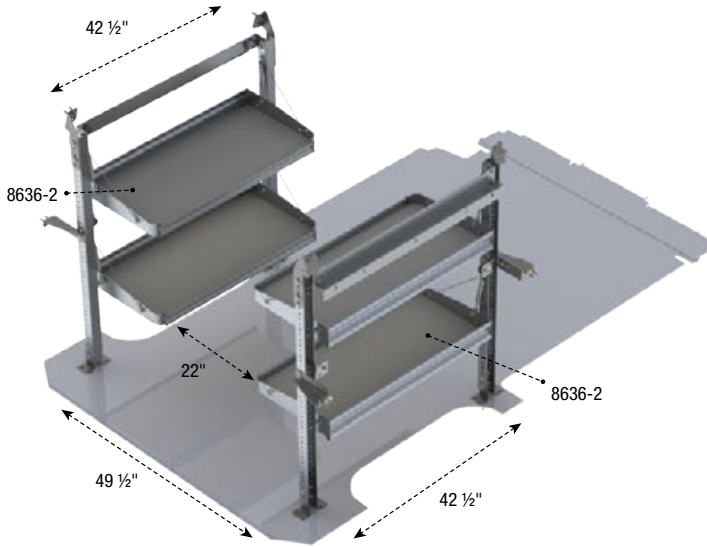

M019

Base Delivery Package

Aluminum

126"	84 lbs	5.2 hrs
Standard	Yes	

Qty	Part #	Description
2	8636-2	Fold-Away Shelving

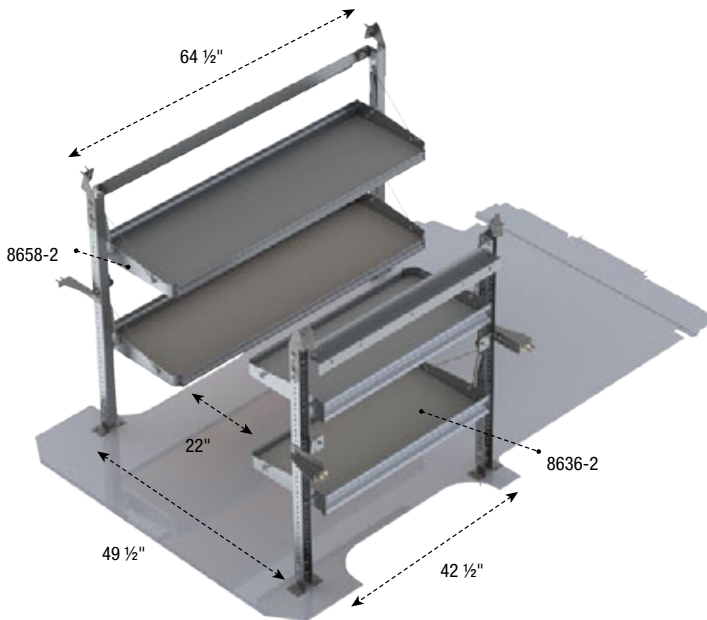

M119

Deluxe Delivery Package

Aluminum

126"	88 lbs	5.2 hrs
Standard	Yes	

Qty	Part #	Description
1	8636-2	Fold-Away Shelving
1	8658-2	Fold-Away Shelving

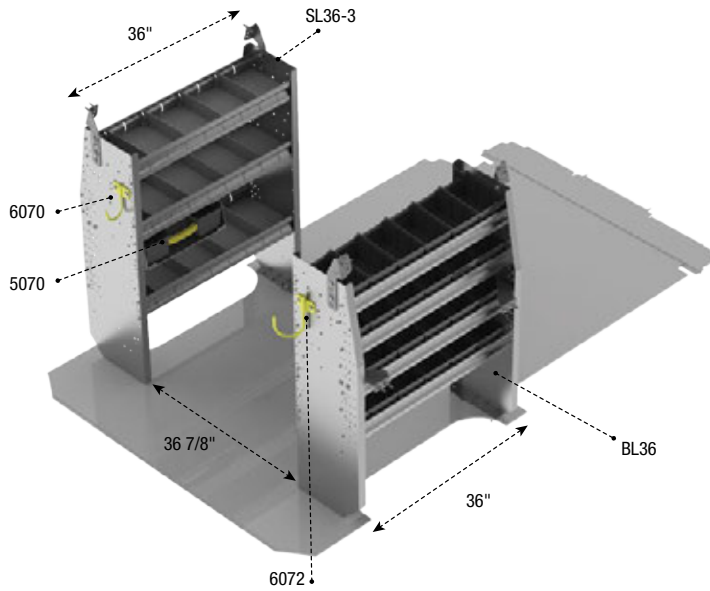

M011

Base Electrical Package

Aluminum

126"	114 lbs	2.7 hrs
Standard	Yes	

Qty	Part #	Description
1	5070	Partskeeper carry case with holder, universal
1	6070	6" Hook, 3" opening, painted
1	6072	8" Swivel Hook, 4" opening, painted
1	BL36	Contoured Bin Shelving Unit
1	SL36-3	Contoured Shelving Unit with Dividers

PACKAGES

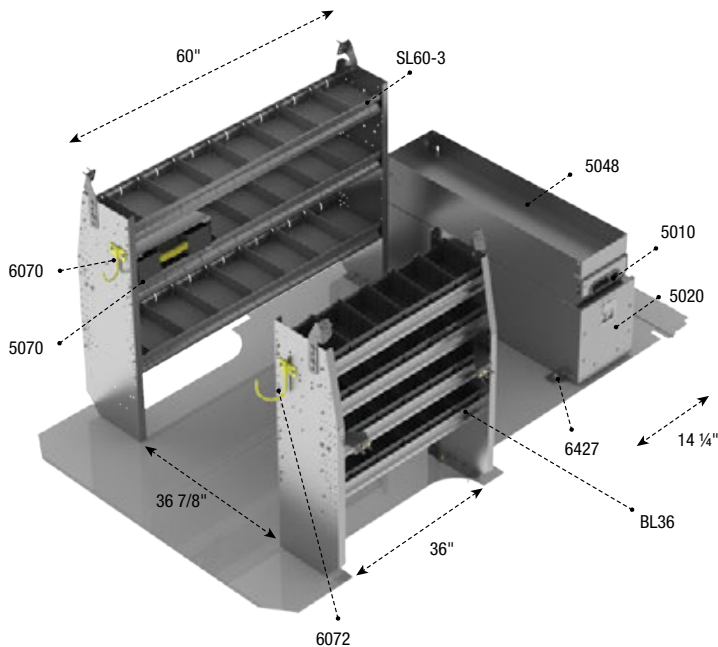

M111

Deluxe Electrical Package

Aluminum

126"	216 lbs	4.9 hrs
Standard	Yes	

Qty	Part #	Description
1	5010	Partslider drawer
1	5020	Tool drawer
1	5048	Top edge, for 5010 Partslider
1	5070	Partskeeper carry case with holder, universal
1	6070	6" Hook, 3" opening, painted
1	6072	8" Swivel Hook, 4" opening, painted
1	6427	5020 / 5025 Tool drawer install kit, Mercedes Metris
1	BL36	Contoured Bin Shelving Unit
1	SL60-3	Contoured Shelving Unit with Dividers

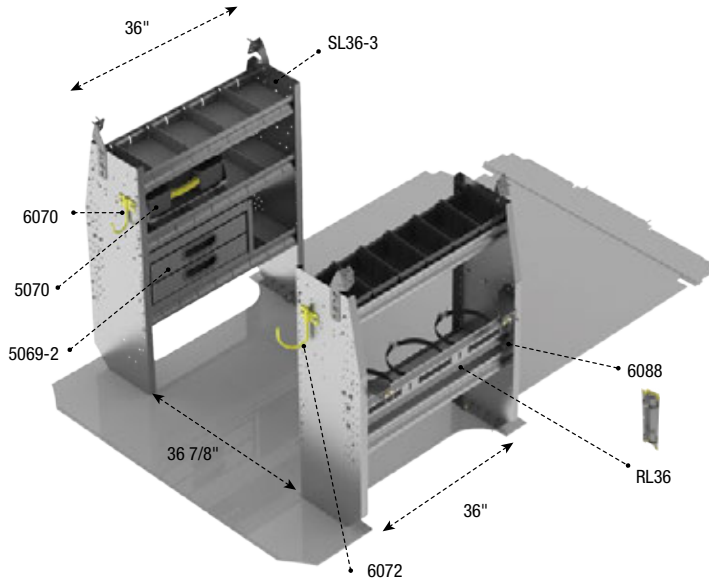

M012

Base HVAC Package

Aluminum

126"	126 lbs	3.4 hrs
Standard	Yes	

Qty	Part #	Description
1	5069-2	2 Drawer cabinet
1	5070	Partskeeper carry case with holder, universal
1	6070	6" Hook, 3" opening, painted
1	6072	8" Swivel Hook, 4" opening, painted
1	6088	Large aluminum bottle holder, with two black nylon straps
1	RL36	Contoured Refrigerant Bin Unit
1	SL36-3	Contoured Shelving Unit with Dividers

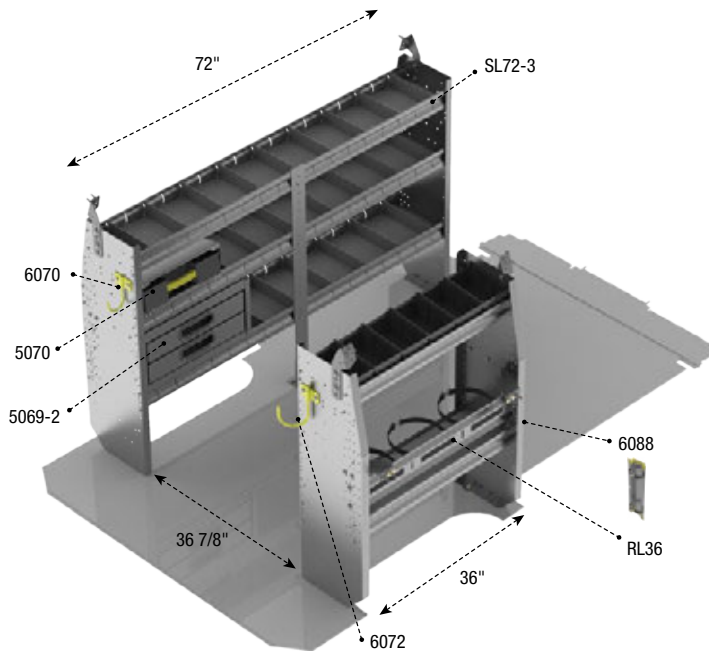

M112

Deluxe HVAC Package

Aluminum

126"	155 lbs	3.4 hrs
Standard	Yes	

Qty	Part #	Description
1	5069-2	2 Drawer cabinet
1	5070	Partskeeper carry case with holder, universal
1	6070	6" Hook, 3" opening, painted
1	6072	8" Swivel Hook, 4" opening, painted
1	6088	Large aluminum bottle holder, with two black nylon straps
1	RL36	Contoured Refrigerant Bin Unit
1	SL72-3	Contoured Shelving Unit with Dividers

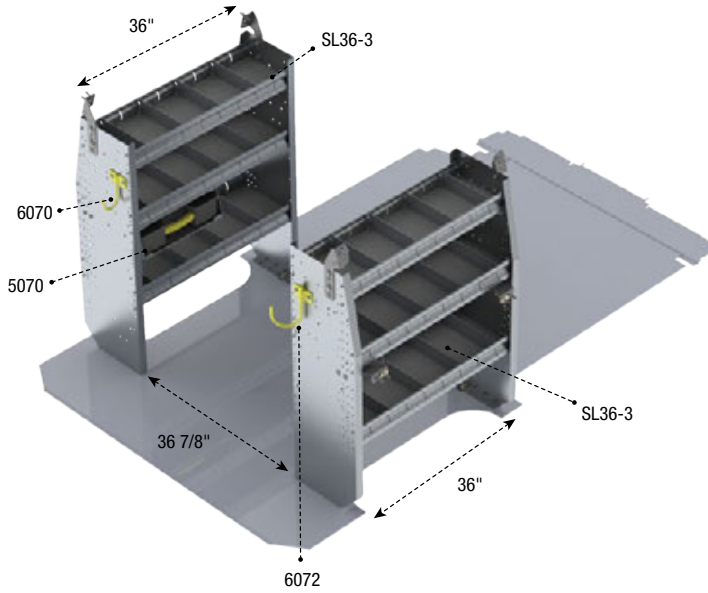

M016

Base Service Package

Aluminum

126"	96 lbs	2.7 hrs
Standard	Yes	

Qty	Part #	Description
1	5070	Partskeeper carry case with holder, universal
1	6070	6" Hook, 3" opening, painted
1	6072	8" Swivel Hook, 4" opening, painted
2	SL36-3	Contoured Shelving Unit with Dividers

PACKAGES

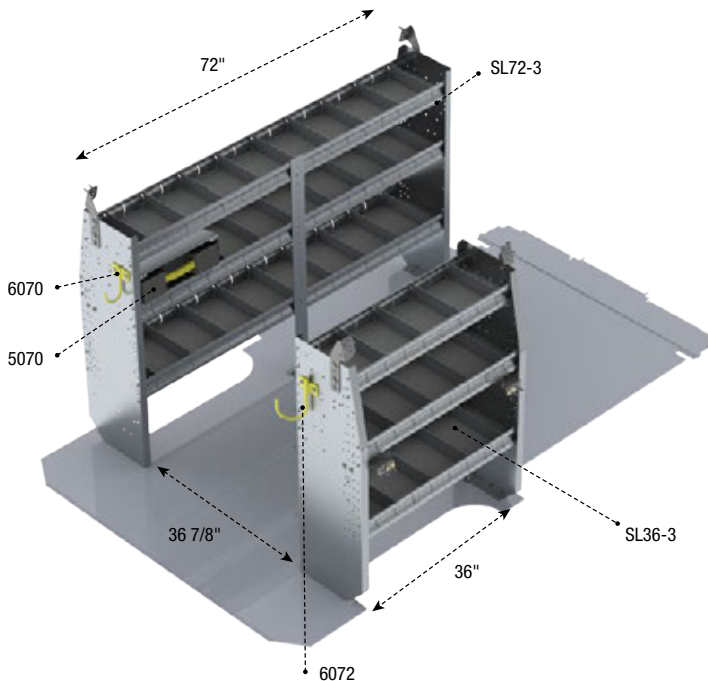

M116

Deluxe Service Package

Aluminum

126"	125 lbs	2.7 hrs
Standard	Yes	

Qty	Part #	Description
1	5070	Partskeeper carry case with holder, universal
1	6070	6" Hook, 3" opening, painted
1	6072	8" Swivel Hook, 4" opening, painted
1	SL36-3	Contoured Shelving Unit with Dividers
1	SL72-3	Contoured Shelving Unit with Dividers

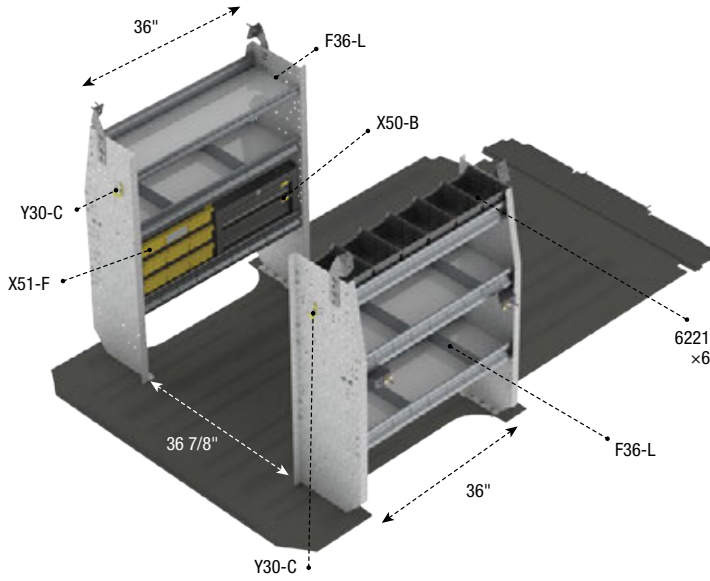

Z16-M0

Base Service Package

Steel

126"	141 lbs	3 hrs
Standard	Yes	

Qty	Part #	Description
6	6221	Medium Bin, Graphite
2	F36-L	Contoured Shelving Unit with Dividers
1	X50-B	Compact 2-Drawer Unit
1	X51-F	Compact 9-Drawer Unit
2	Y30-C	Coat Hook, 1" opening, chrome plated

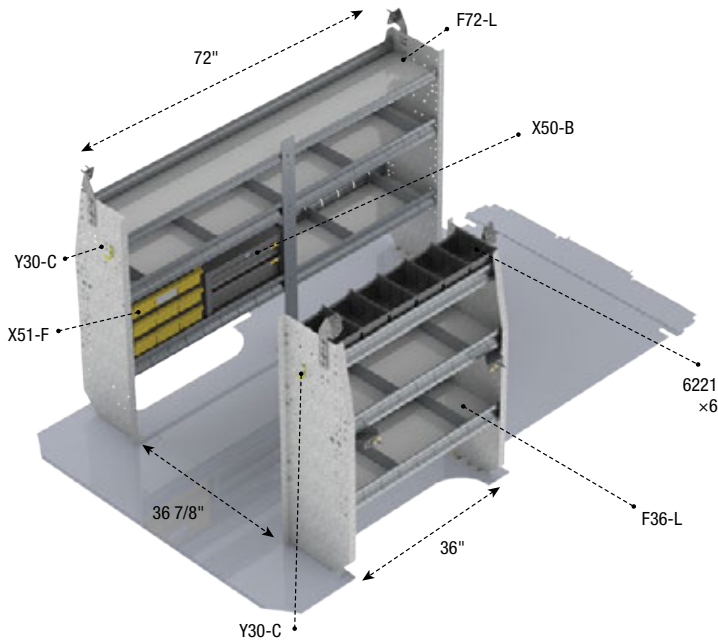

Z16-M1

Deluxe Service Package

Steel

126"	162 lbs	3 hrs
Standard	Yes	

Qty	Part #	Description
6	6221	Medium Bin, Graphite
1	F36-L	Contoured Shelving Unit with Dividers
1	F72-L	Contoured Shelving Unit with Dividers
1	X50-B	Compact 2-Drawer Unit
1	X51-F	Compact 9-Drawer Unit
2	Y30-C	Coat Hook, 1" opening, chrome plated

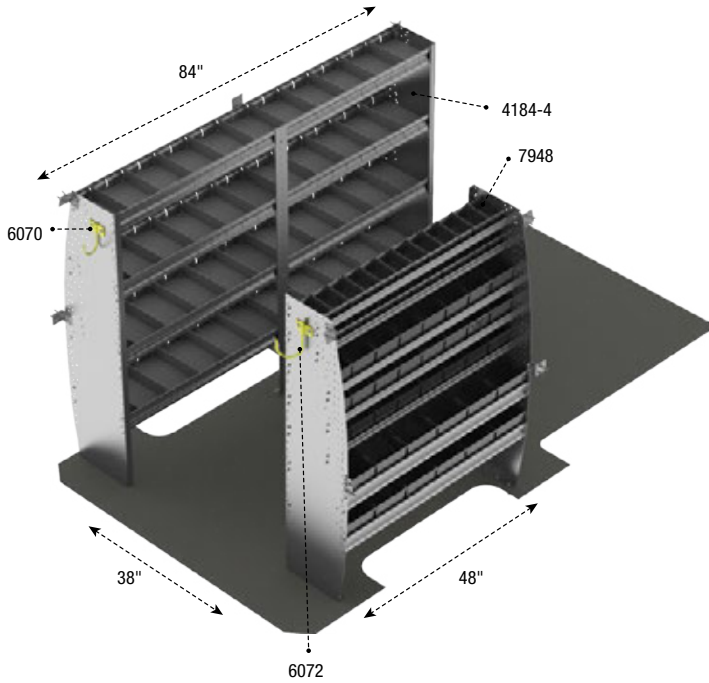

G210

Contractor Package

Aluminum

144"	212 lbs	3.2 hrs
Low / High	Yes	

Qty	Part #	Description
1	4184-4	Contoured Shelving Unit with Dividers
1	6070	6" Hook, 3" opening, painted
1	6072	8" Swivel Hook, 4" opening, painted
1	7948	Contoured Bin Shelving Unit

PACKAGES

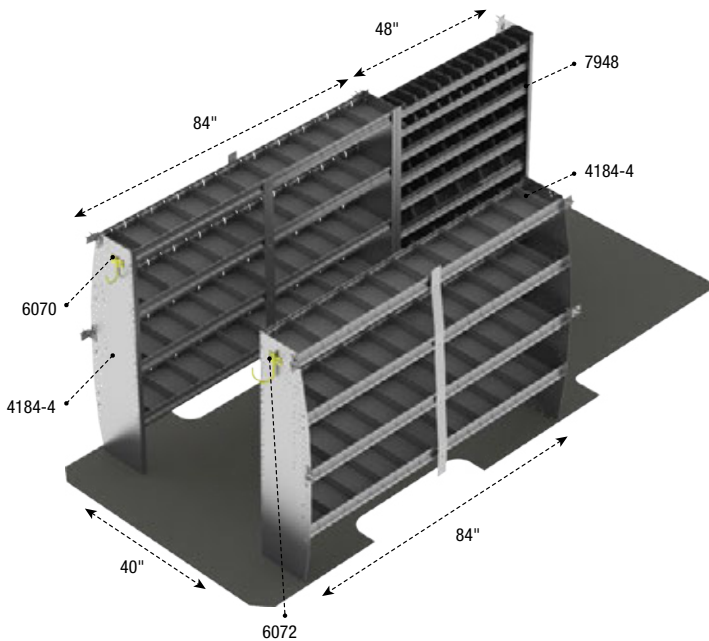

G710

Contractor Package

Aluminum

170", 170" Ext	300 lbs	4.6 hrs
High	Yes	

Qty	Part #	Description
2	4184-4	Contoured Shelving Unit with Dividers
1	6070	6" Hook, 3" opening, painted
1	6072	8" Swivel Hook, 4" opening, painted
1	7948	Contoured Bin Shelving Unit



G217

Service Package

Tradesmen proven tough and guaranteed to work as hard as you do.



QUIET
The combination of the extrusion, shelf tray, and end-panels create durable, vibration-free ride.



EFFICIENT
Ergonomic design reduces injuries and increases productivity.



TOUGH
Extrusion builds durability into shelf.

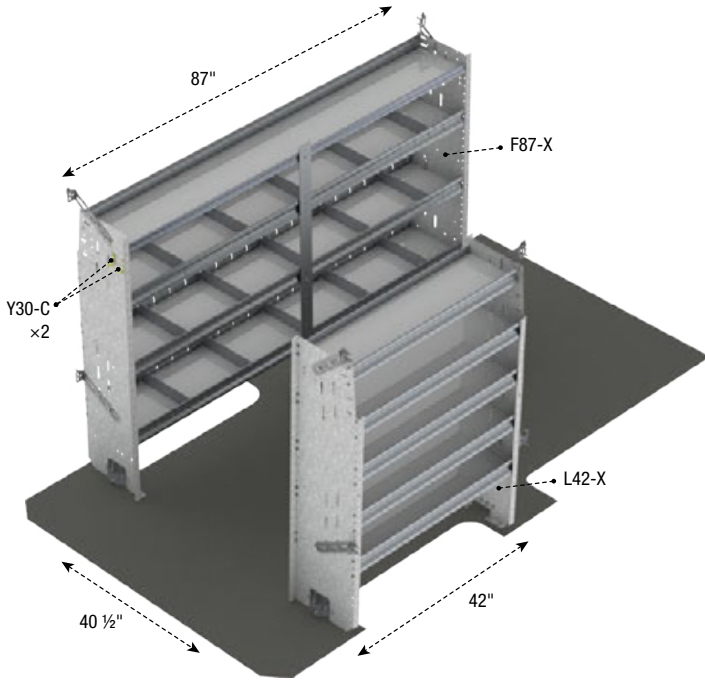

Z10-G2

Contractor Package

Steel

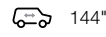

144"



207 lbs



2.4 hrs



Low / High



Yes

Qty	Part #	Description
1	F87-X	Square Back Shelving Unit with Dividers
1	L42-X	Square Back Shelving Unit
2	Y30-C	Coat Hook, 1" opening, chrome plated

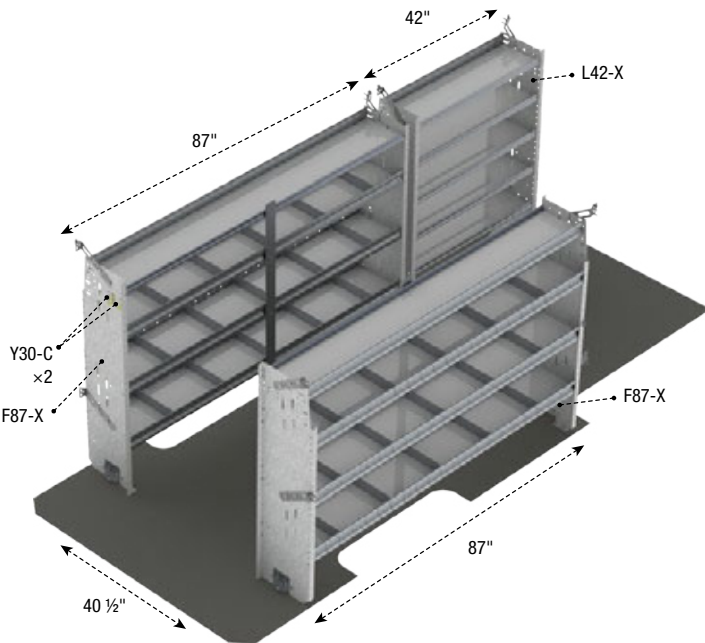

Z10-G7

Contractor Package

Steel



170", 170" Ext



332 lbs



3.4 hrs



High



Yes

Qty	Part #	Description
2	F87-X	Square Back Shelving Unit with Dividers
1	L42-X	Square Back Shelving Unit
2	Y30-C	Coat Hook, 1" opening, chrome plated

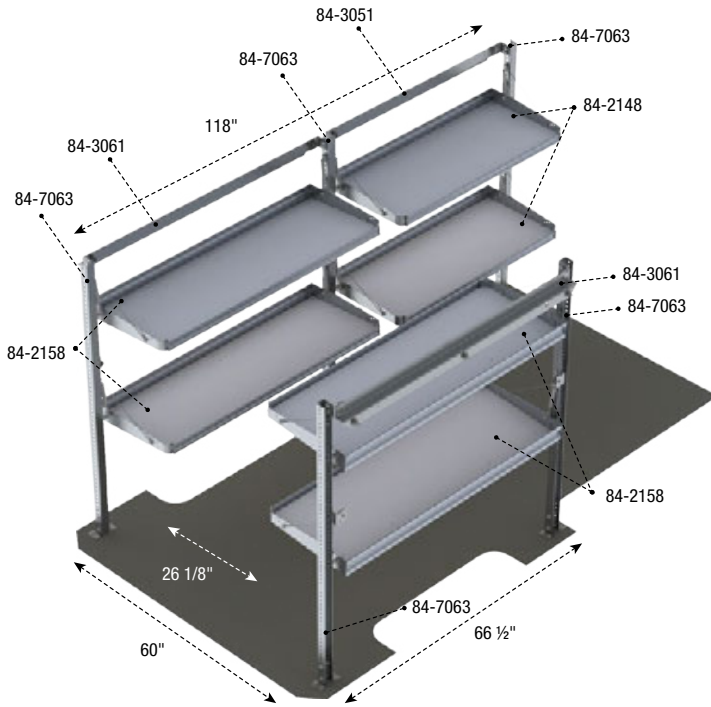

G219

Delivery Package

Aluminum

144"	181 lbs	7.3 hrs
Low / High	Yes	

Qty	Part #	Description
2	84-2148	Fold-Away Shelf Tray with Gas Shocks and Hardware
4	84-2158	Fold-Away Shelf Tray with Gas Shocks and Hardware
1	84-3051	Mounting Bar Assembly for Fold-Away Shelving
2	84-3061	Mounting Bar Assembly for Fold-Away Shelving
5	84-7063	Post Assembly for Fold-Away Shelving

PACKAGES

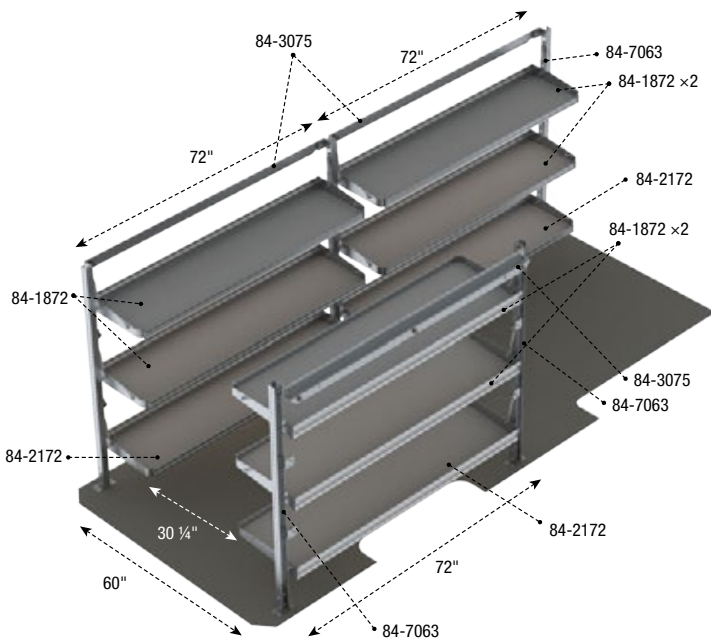

G719

Delivery Package

Aluminum

170", 170" Ext	293 lbs	8.2 hrs
High	Yes	

Qty	Part #	Description
6	84-1872	Fold-Away Shelf Tray with Gas Shocks and Hardware
3	84-2172	Fold-Away Shelf Tray with Gas Shocks and Hardware
3	84-3075	Mounting Bar Assembly for Fold-Away Shelving
5	84-7063	Post Assembly for Fold-Away Shelving

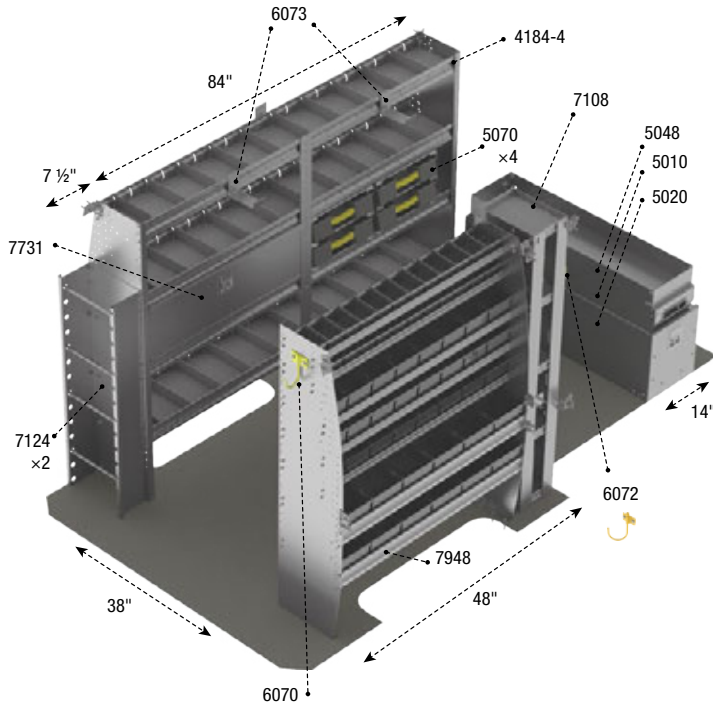

G211

Electrical Package

Aluminum

144"	379 lbs	8.1 hrs
Low / High	Yes	

Qty	Part #	Description
1	4184-4	Contoured Shelving Unit with Dividers
1	5010	Partslider drawer
1	5020	Tool drawer
1	5048	Top edge, for 5010 Partslider
4	5070	Partskeeper carry case with holder, universal
1	6070	6" Hook, 3" opening, painted
1	6072	8" Swivel Hook, 4" opening, painted
2	6073	Large aluminum movable hook, 6.5" opening
1	7108	Bookshelf
2	7124	Reel Holder with two 5/8" diameter rods
1	7731	Locking door kit
1	7948	Contoured Bin Shelving Unit

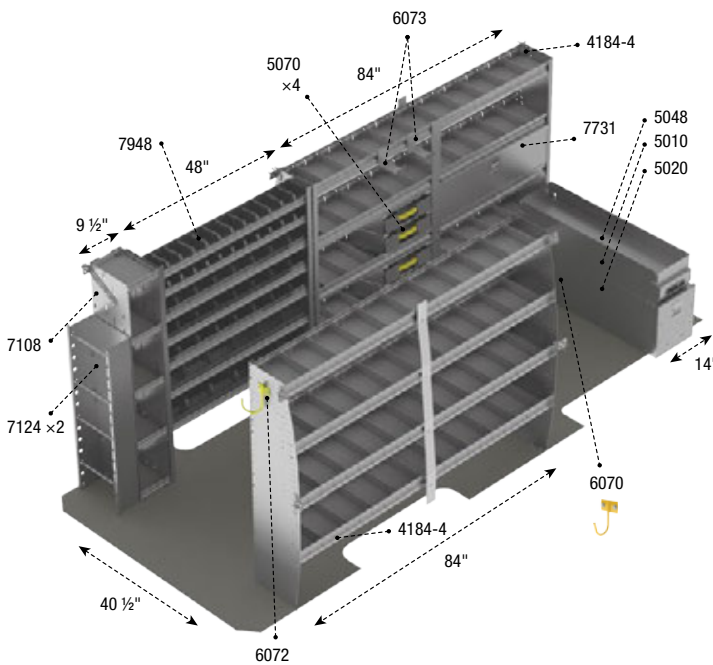

G711

Electrical Package

Aluminum

170", 170" Ext	467 lbs	9.5 hrs
High	Yes	

Qty	Part #	Description
2	4184-4	Contoured Shelving Unit with Dividers
1	5010	Partslider drawer
1	5020	Tool drawer
1	5048	Top edge, for 5010 Partslider
4	5070	Partskeeper carry case with holder, universal
1	6070	6" Hook, 3" opening, painted
1	6072	8" Swivel Hook, 4" opening, painted
2	6073	Large aluminum movable hook, 6.5" opening
1	7108	Bookshelf
2	7124	Reel Holder with two 5/8" diameter rods
1	7731	Locking door kit
1	7948	Contoured Bin Shelving Unit

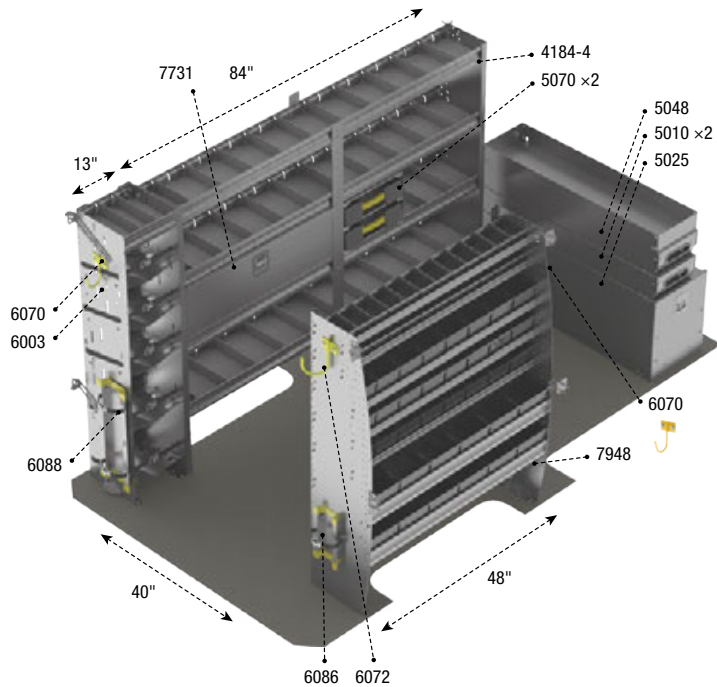

G212

HVAC Package

Aluminum

144"

399 lbs

7.8 hrs

Low / High

Yes

Qty	Part #	Description
1	4184-4	Contoured Shelving Unit with Dividers
2	5010	Partslider drawer
1	5025	Jumbo tool drawer
1	5048	Top edge, for 5010 Partslider
2	5070	Partskeeper carry case with holder, universal
1	6003	5 Tier refrigerant rack for large bottles
2	6070	6" Hook, 3" opening, painted
1	6072	8" Swivel Hook, 4" opening, painted
1	6086	Small aluminum bottle holder, with a black nylon strap
1	6088	Large aluminum bottle holder, with two black nylon straps
1	7731	Locking door kit
1	7948	Contoured Bin Shelving Unit

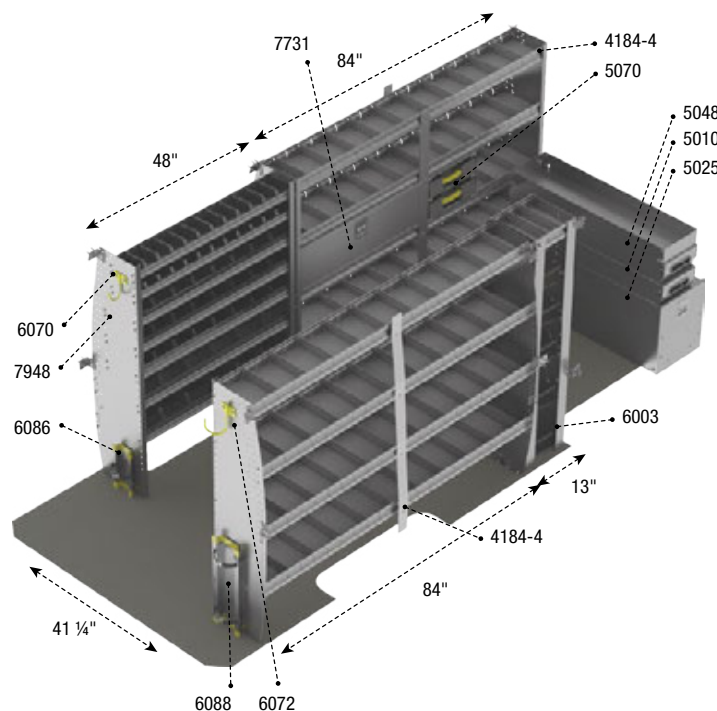

G712

HVAC Package

Aluminum

170", 170" Ext

487 lbs

9 hrs

High

Yes

Qty	Part #	Description
2	4184-4	Contoured Shelving Unit with Dividers
2	5010	Partslider drawer
1	5025	Jumbo tool drawer
1	5048	Top edge, for 5010 Partslider
2	5070	Partskeeper carry case with holder, universal
1	6003	5 Tier refrigerant rack for large bottles
1	6070	6" Hook, 3" opening, painted
1	6072	8" Swivel Hook, 4" opening, painted
1	6086	Small aluminum bottle holder, with a black nylon strap
1	6088	Large aluminum bottle holder, with two black nylon straps
1	7731	Locking door kit
1	7948	Contoured Bin Shelving Unit

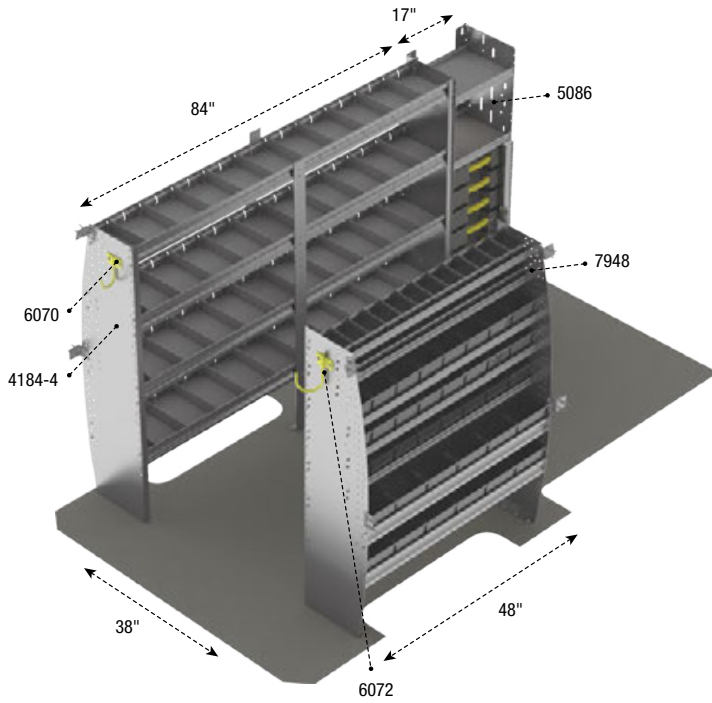

G215

Plumber Package

Aluminum



144"



269 lbs



4.2 hrs



Low / High



Yes

Qty	Part #	Description
1	4184-4	Contoured Shelving Unit with Dividers
1	5086	Partskeeper cabinet with 8 carry cases & 2 shelves
1	6070	6" Hook, 3" opening, painted
1	6072	8" Swivel Hook, 4" opening, painted
1	7948	Contoured Bin Shelving Unit

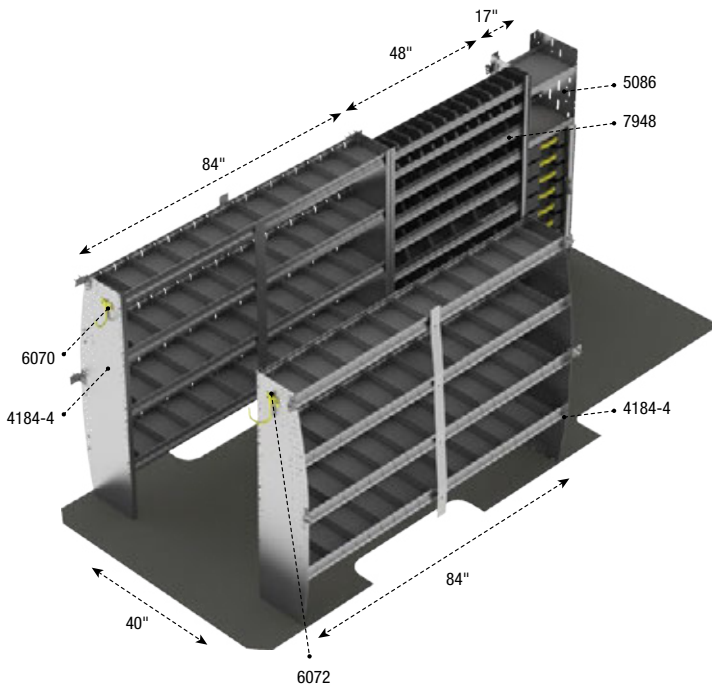

G715

Plumber Package

Aluminum



170", 170" Ext



357 lbs



5.6 hrs



High



Yes

Qty	Part #	Description
2	4184-4	Contoured Shelving Unit with Dividers
1	5086	Partskeeper cabinet with 8 carry cases & 2 shelves
1	6070	6" Hook, 3" opening, painted
1	6072	8" Swivel Hook, 4" opening, painted
1	7948	Contoured Bin Shelving Unit

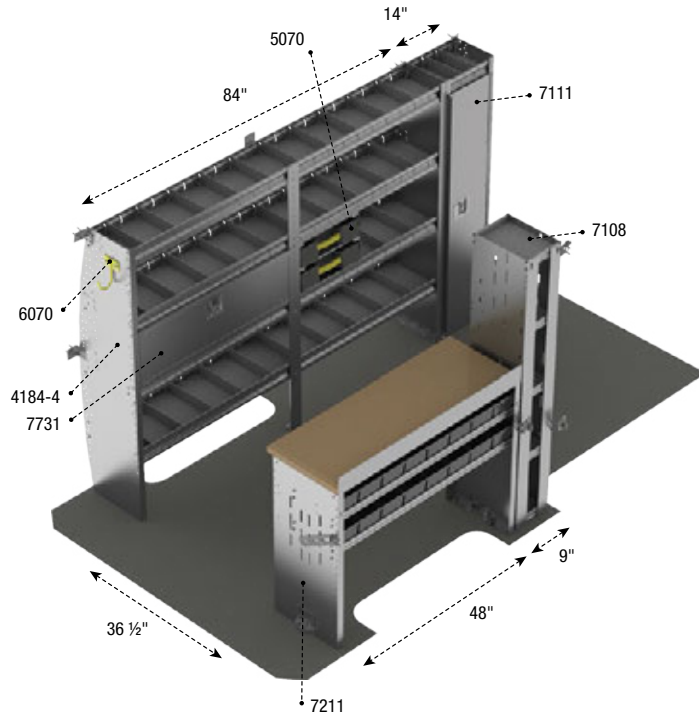

G216

Service Package

Aluminum

144"	250 lbs	5.2 hrs
Low / High	Yes	

Qty	Part #	Description
1	4184-4	Contoured Shelving Unit with Dividers
2	5070	Partskeeper carry case with holder, universal
1	6070	6" Hook, 3" opening, painted
1	7108	Bookshelf
1	7111	Contoured locker w/top shelf
1	7211	Workbench w/hardwood top, 2 bin shelves
1	7731	Locking door kit

PACKAGES

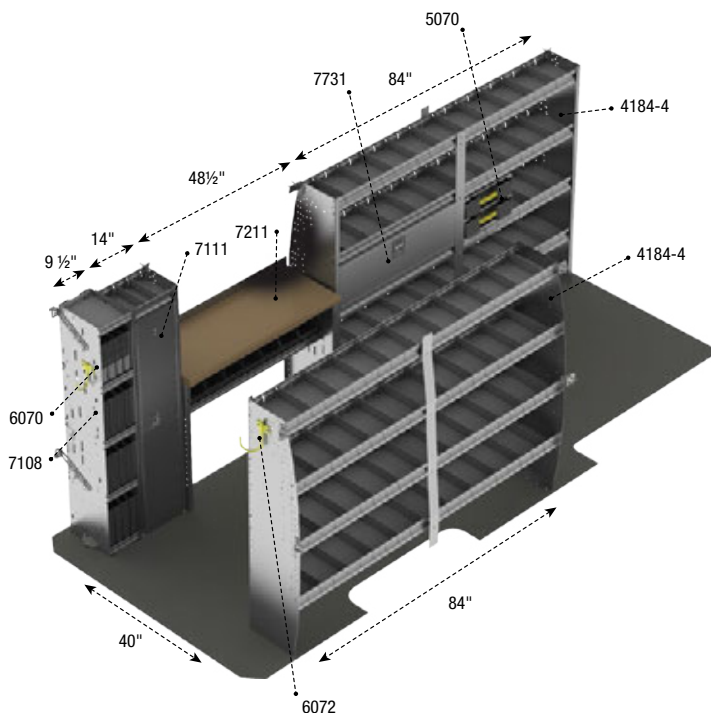

G716

Service Package

Aluminum

170", 170" Ext	339 lbs	6.8 hrs
High	Yes	

Qty	Part #	Description
2	4184-4	Contoured Shelving Unit with Dividers
2	5070	Partskeeper carry case with holder, universal
1	6070	6" Hook, 3" opening, painted
1	6072	8" Swivel Hook, 4" opening, painted
1	7108	Bookshelf
1	7111	Contoured locker w/top shelf
1	7211	Workbench w/hardwood top, 2 bin shelves
1	7731	Locking door kit

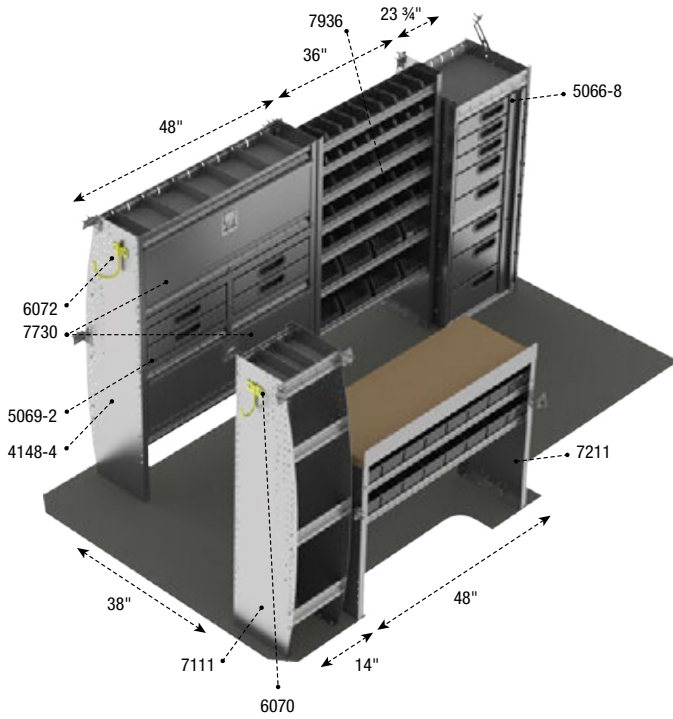

G217

Service Package

Aluminum

144"

518 lbs

8 hrs

Low / High

No

Qty	Part #	Description
1	4148-4	Contoured Shelving Unit with Dividers
1	5066-8	8 Drawer cabinet, contoured
2	5069-2	2 Drawer cabinet
1	6070	6" Hook, 3" opening, painted
1	6072	8" Swivel Hook, 4" opening, painted
1	7111	Contoured locker w/top shelf
1	7211	Workbench w/hardwood top, 2 bin shelves
2	7730	Locking door kit
1	7936	Contoured Bin Shelving Unit

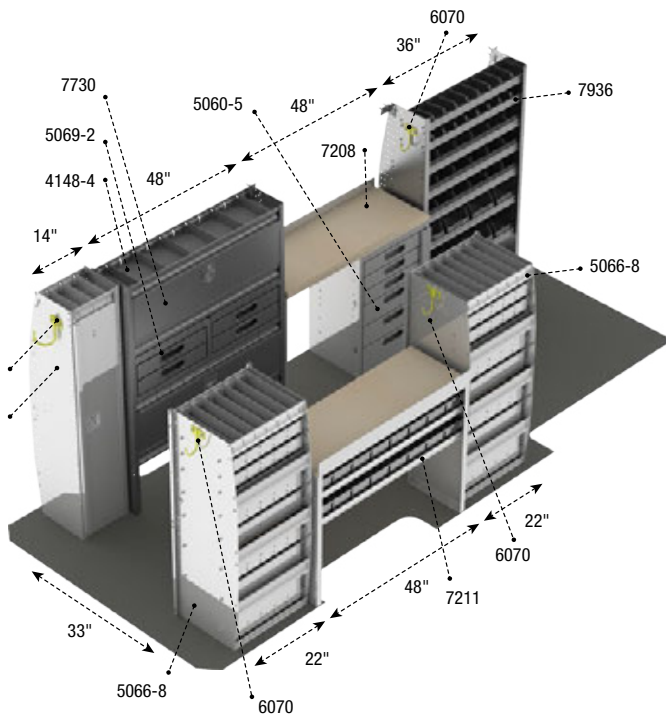

G717

Service Package

Aluminum

170", 170" Ext

838 lbs

10.9 hrs

High

No

Qty	Part #	Description
1	4148-4	Contoured Shelving Unit with Dividers
1	5060-5	5 Drawer cabinet
2	5066-8	8 Drawer cabinet, contoured
2	5069-2	2 Drawer cabinet
3	6070	6" Hook, 3" opening, painted
1	6072	8" Swivel Hook, 4" opening, painted
1	7111	Contoured locker w/top shelf
1	7208	Workbench w/hardwood top, one end panel
1	7211	Workbench w/hardwood top, 2 bin shelves
2	7730	Locking door kit
1	7936	Contoured Bin Shelving Unit

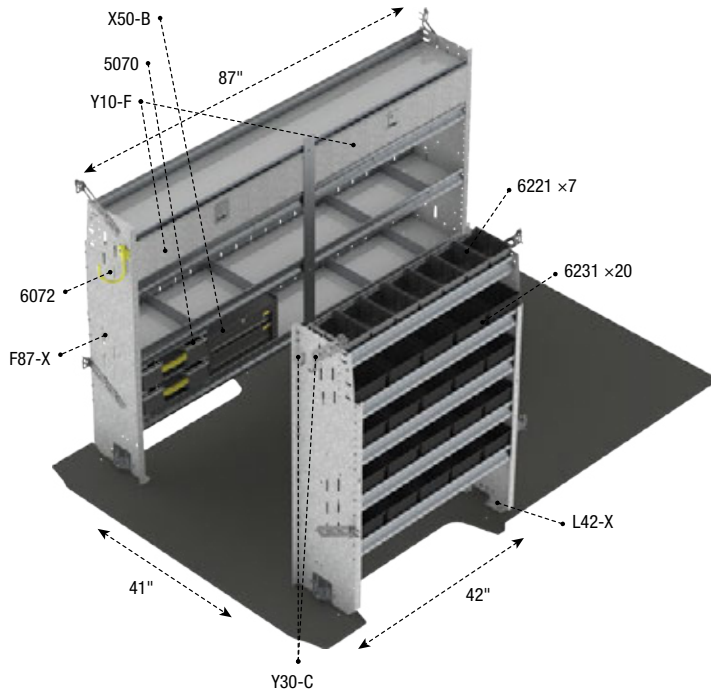

Z16-G2

Service Package

Steel

144"	295 lbs	4.5 hrs
Low / High	Yes	

Qty	Part #	Description
2	5070	Partskeeper carry case with holder, universal
1	6072	8" Swivel Hook, 4" opening, painted
7	6221	Medium Bin, Graphite
20	6231	Large Bin, Graphite
1	F87-X	Square Back Shelving Unit with Dividers
1	L42-X	Square Back Shelving Unit
1	X50-B	Compact 2-Drawer Unit
2	Y10-F	Locking door kit
2	Y30-C	Coat Hook, 1" opening, chrome plated

PACKAGES

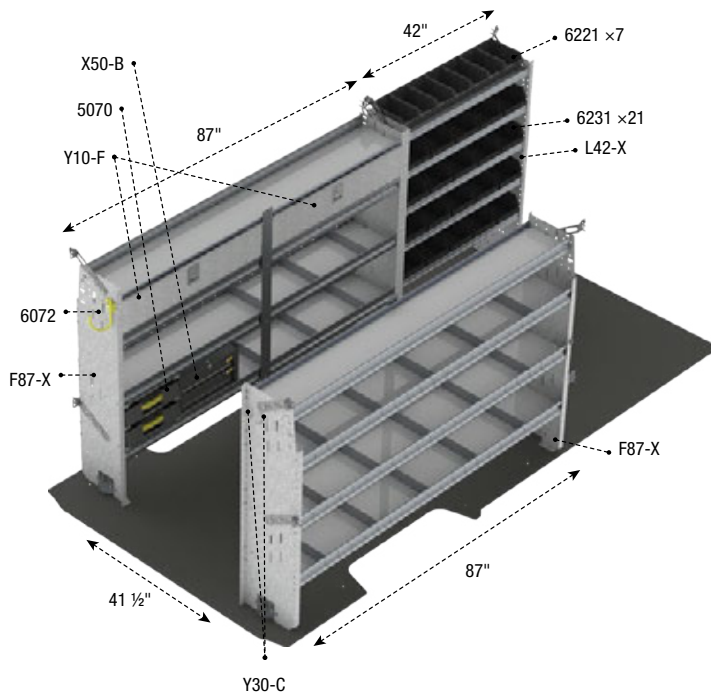

Z16-G7

Service Package

Steel

170", 170" Ext	420 lbs	5.5 hrs
High	Yes	

Qty	Part #	Description
2	5070	Partskeeper carry case with holder, universal
1	6072	8" Swivel Hook, 4" opening, painted
7	6221	Medium Bin, Graphite
20	6231	Large Bin, Graphite
2	F87-X	Square Back Shelving Unit with Dividers
1	L42-X	Square Back Shelving Unit
1	X50-B	Compact 2-Drawer Unit
2	Y10-F	Locking door kit
2	Y30-C	Coat Hook, 1" opening, chrome plated



K115

Plumber Package

Layout design is a perfect fit for your toughest job.

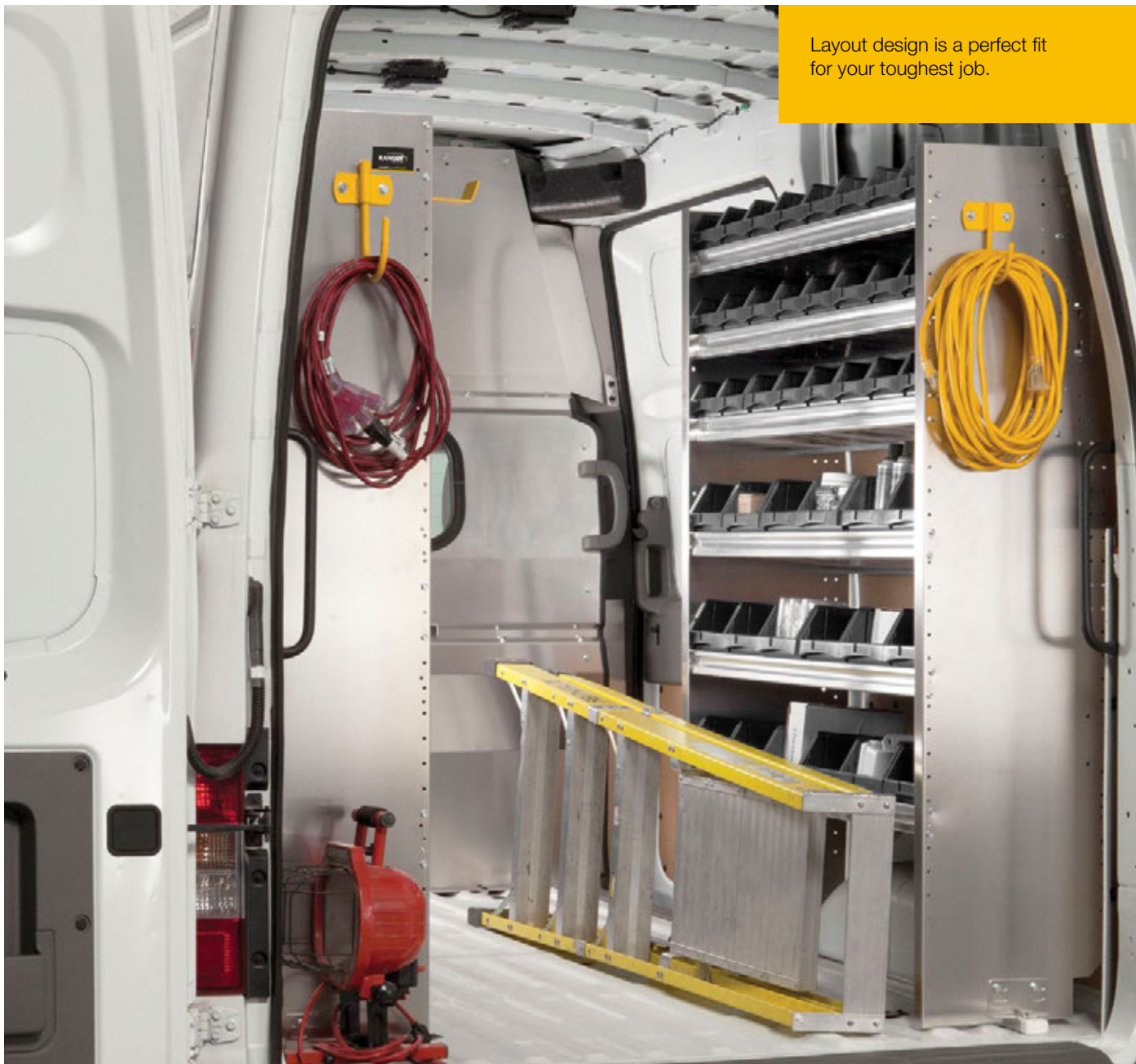

QUIET

The combination of the extrusion, shelf tray, and end-panels create durable, vibration-free shelves.



EFFICIENT

Ergonomic design reduces injuries and increases productivity.



TOUGH

Extrusion builds durability into shelf.

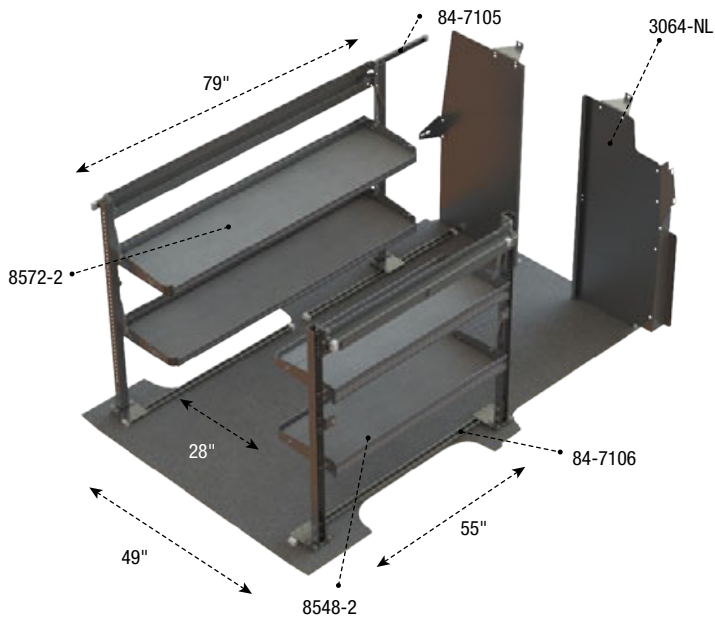

K019

Delivery Package

Aluminum

146"	162 lbs	5.8 hrs
Low	No	

Qty	Part #	Description
1	3064-NL	Straight Walk Through Partition
1	84-7105	Fold-Away shelving install kit, driver side
1	84-7106	Fold-Away shelving install kit, passenger side
1	8548-2	Fold-Away Shelving
1	8572-2	Fold-Away Shelving

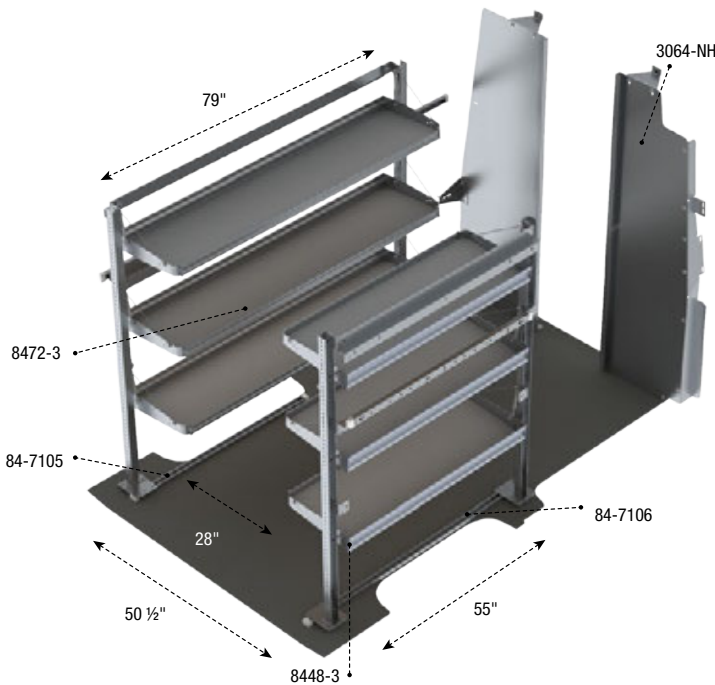

K119

Delivery Package

Aluminum

146"	232 lbs	6.2 hrs
High	No	

Qty	Part #	Description
1	3064-NH	Straight Walk Through Partition
1	84-7105	Fold-Away shelving install kit, driver side
1	84-7106	Fold-Away shelving install kit, passenger side
1	8448-3	Fold-Away Shelving
1	8472-3	Fold-Away Shelving

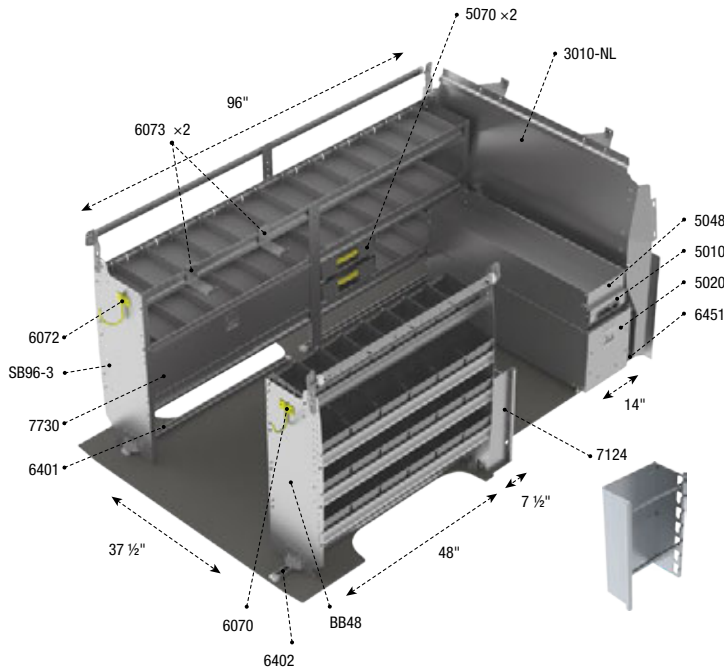

K011

Electrical Package

Aluminum

146"

325 lbs

6.7 hrs

Low

No

Qty	Part #	Description
1	3010-NL	Contoured Safety Partition
1	5010	Partslider drawer
1	5020	Tool drawer
1	5048	Top edge, for 5010 Partslider
2	5070	Partskeeper carry case with holder, universal
1	6070	6" Hook, 3" opening, painted
1	6072	8" Swivel Hook, 4" opening, painted
2	6073	Large aluminum movable hook, 6.5" opening
1	6401	Shelving install track kit, driver side
1	6402	Shelving install track kit, passenger side
1	6451	Tool drawer install kit
1	7124	Reel Holder with two 5/8" diameter rods
1	7730	Locking door kit
1	BB48	Contoured Bin Shelving Unit
1	SB96-3	Contoured Shelving Unit with Dividers

PACKAGES

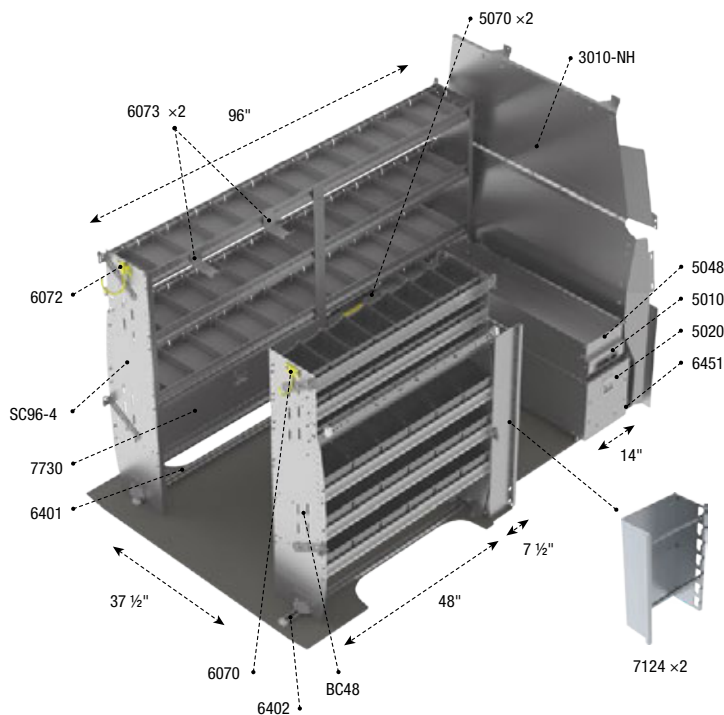

K111

Electrical Package

Aluminum

146"

385 lbs

8.2 hrs

High

No

Qty	Part #	Description
1	3010-NH	Contoured Safety Partition
1	5010	Partslider drawer
1	5020	Tool drawer
1	5048	Top edge, for 5010 Partslider
2	5070	Partskeeper carry case with holder, universal
1	6070	6" Hook, 3" opening, painted
1	6072	8" Swivel Hook, 4" opening, painted
2	6073	Large aluminum movable hook, 6.5" opening
1	6401	Shelving install track kit, driver side
1	6402	Shelving install track kit, passenger side
1	6451	Tool drawer install kit
2	7124	Reel Holder with two 5/8" diameter rods
1	7730	Locking door kit
1	BC48	Contoured Bin Shelving Unit
1	SC96-4	Contoured Shelving Unit with Dividers

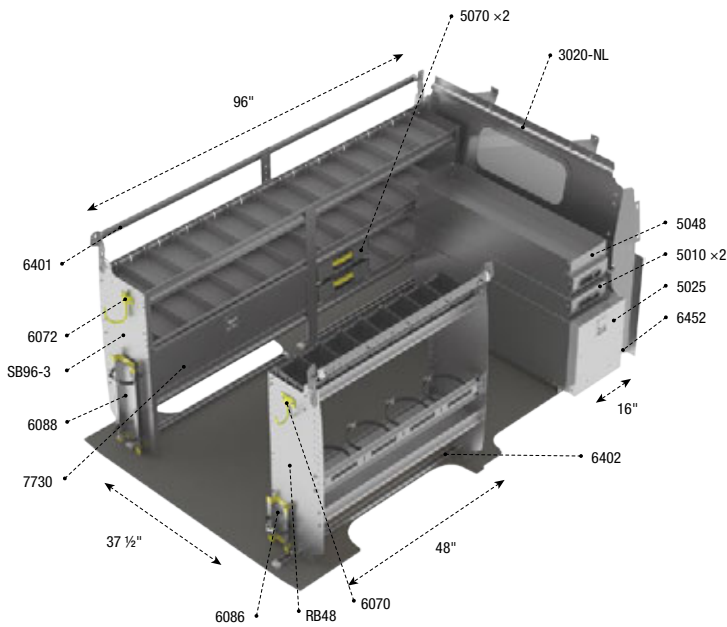

K012

HVAC Package

Aluminum

146"

319 lbs

7.1 hrs

Low

No

Qty	Part #	Description
1	3020-NL	Contoured Safety Partition with Tempered Glass Window
2	5010	Partslider drawer
1	5025	Jumbo tool drawer
1	5048	Top edge, for 5010 Partslider
2	5070	Partskeeper carry case with holder, universal
1	6070	6" Hook, 3" opening, painted
1	6072	8" Swivel Hook, 4" opening, painted
1	6086	Small aluminum bottle holder, with a black nylon strap
1	6088	Large aluminum bottle holder, with two black nylon straps
1	6401	Shelving install track kit, driver side
1	6402	Shelving install track kit, passenger side
1	6452	5025 Tool drawer install kit
1	7730	Locking door kit
1	RB48	Contoured Refrigerant Bin Unit
1	SB96-3	Contoured Shelving Unit with Dividers

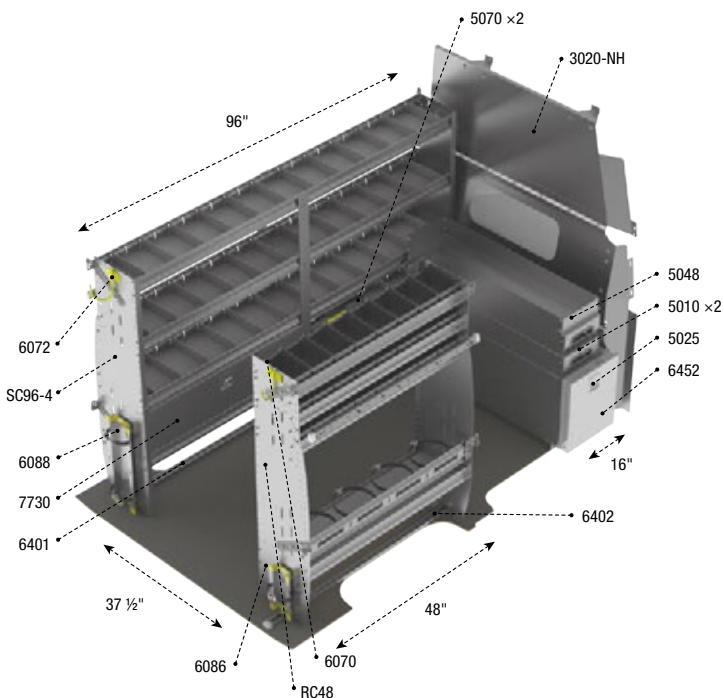

K112

HVAC Package

Aluminum

146"

415 lbs

7.9 hrs

High

No

Qty	Part #	Description
1	3020-NH	Contoured Safety Partition with Tempered Glass Window
2	5010	Partslider drawer
1	5025	Jumbo tool drawer
1	5048	Top edge, for 5010 Partslider
2	5070	Partskeeper carry case with holder, universal
1	6070	6" Hook, 3" opening, painted
1	6072	8" Swivel Hook, 4" opening, painted
1	6086	Small aluminum bottle holder, with a black nylon strap
1	6088	Large aluminum bottle holder, with two black nylon straps
1	6401	Shelving install track kit, driver side
1	6402	Shelving install track kit, passenger side
1	6452	5025 Tool drawer install kit
1	7730	Locking door kit
1	RC48	Contoured Refrigerant Bin Unit
1	SC96-4	Contoured Shelving Unit with Dividers

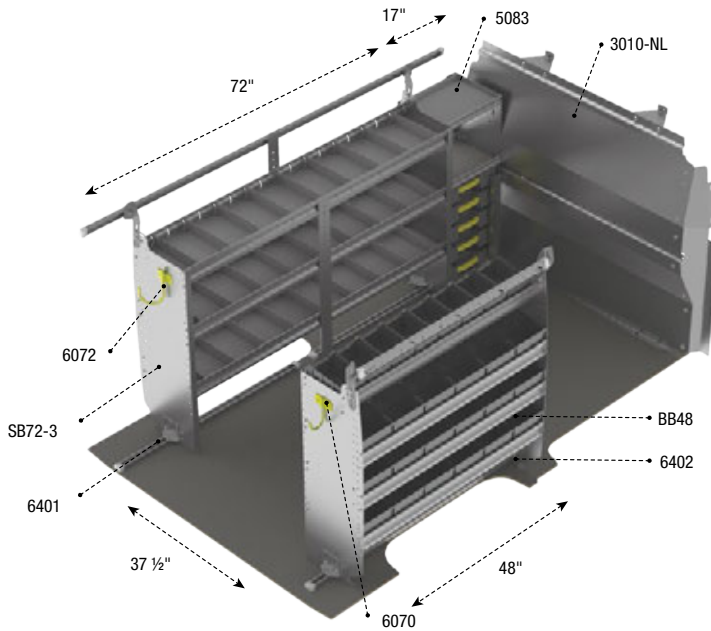

K015

Plumber Package

Aluminum

146"

233 lbs

4.4 hrs

Low

Yes

Qty	Part #	Description
1	3010-NL	Contoured Safety Partition
1	5083	Partskeeper cabinet with 5 carry cases & 2 shelves
1	6070	6" Hook, 3" opening, painted
1	6072	8" Swivel Hook, 4" opening, painted
1	6401	Shelving install track kit, driver side
1	6402	Shelving install track kit, passenger side
1	BB48	Contoured Bin Shelving Unit
1	SB72-3	Contoured Shelving Unit with Dividers

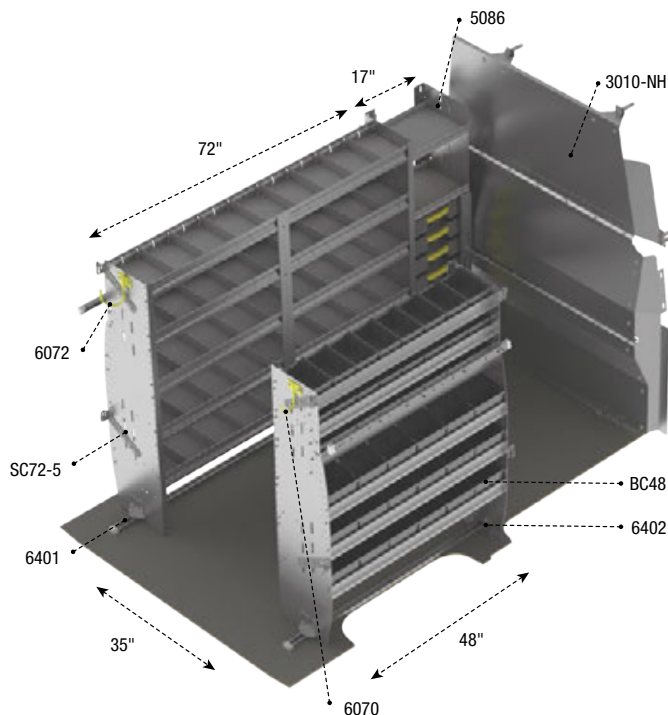

K115

Plumber Package

Aluminum

146"

311 lbs

5.4 hrs

High

Yes

Qty	Part #	Description
1	3010-NH	Contoured Safety Partition
1	5086	Partskeeper cabinet with 8 carry cases & 2 shelves
1	6070	6" Hook, 3" opening, painted
1	6072	8" Swivel Hook, 4" opening, painted
1	6401	Shelving install track kit, driver side
1	6402	Shelving install track kit, passenger side
1	BC48	Contoured Bin Shelving Unit
1	SC72-5	Contoured Shelving Unit with Dividers

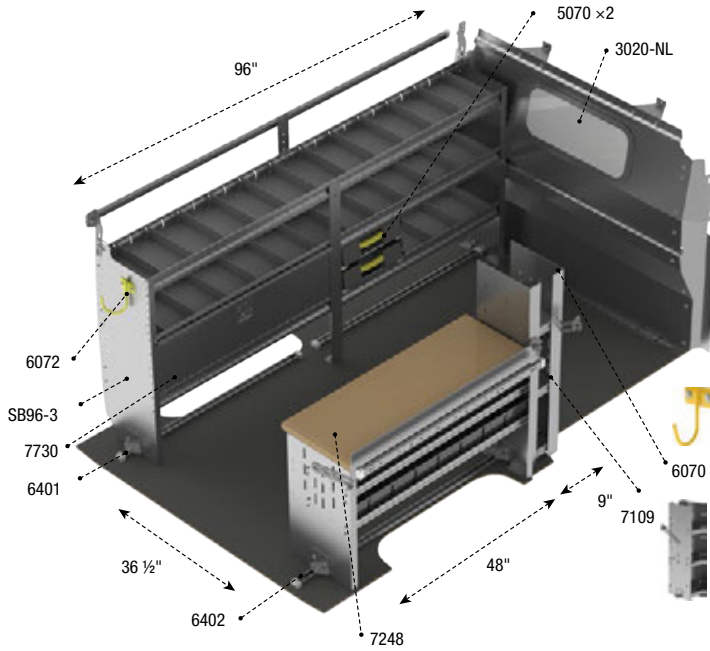

K016

Service Package

Aluminum

146"

245 lbs

4.9 hrs

Low

No

Qty	Part #	Description
1	3020-NL	Contoured Safety Partition with Tempered Glass Window
2	5070	Partskeeper carry case with holder, universal
1	6070	6" Hook, 3" opening, painted
1	6072	8" Swivel Hook, 4" opening, painted
1	6401	Shelving install track kit, driver side
1	6402	Shelving install track kit, passenger side
1	7109	Bookshelf
1	7248	Workbench w/hardwood top, 2 bin shelves
1	7730	Locking door kit
1	SB96-3	Contoured Shelving Unit with Dividers

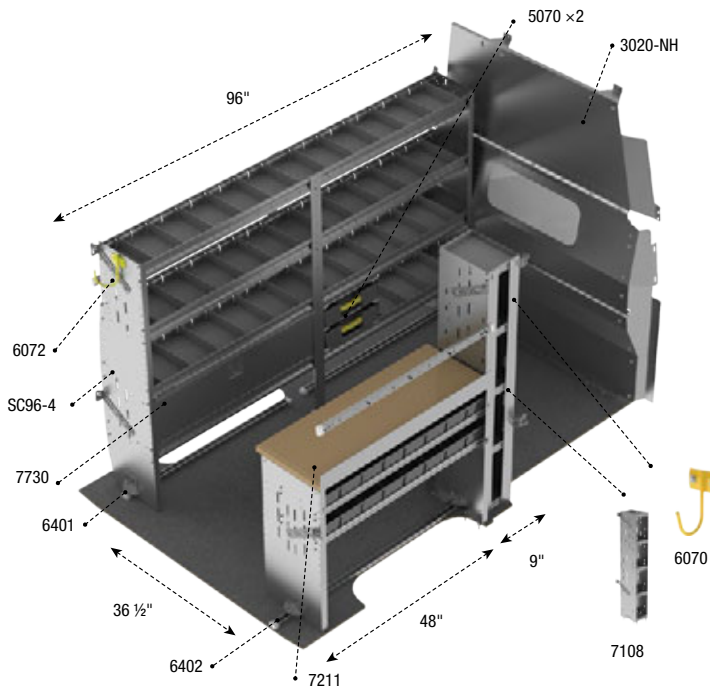

K116

Service Package

Aluminum

146"

285 lbs

5.6 hrs

High

No

Qty	Part #	Description
1	3020-NH	Contoured Safety Partition with Tempered Glass Window
2	5070	Partskeeper carry case with holder, universal
1	6070	6" Hook, 3" opening, painted
1	6072	8" Swivel Hook, 4" opening, painted
1	6401	Shelving install track kit, driver side
1	6402	Shelving install track kit, passenger side
1	7108	Bookshelf
1	7211	Workbench w/hardwood top, 2 bin shelves
1	7730	Locking door kit
1	SC96-4	Contoured Shelving Unit with Dividers

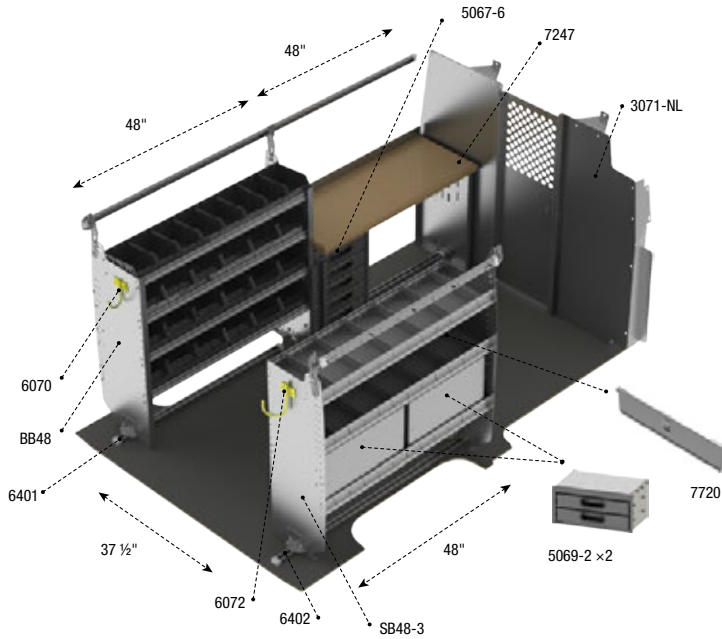

K017

WorkStation Package

Aluminum

146"	405 lbs	6.7 hrs
Low	No	

Qty Part # Description

1	3071-NL	Straight Partition with Perforated Window, Swing Door
1	5067-6	6 Drawer cabinet
2	5069-2	2 Drawer cabinet
1	6070	6" Hook, 3" opening, painted
1	6072	8" Swivel Hook, 4" opening, painted
1	6401	Shelving install track kit, driver side
1	6402	Shelving install track kit, passenger side
1	7247	Workbench w/hardwood top, one end panel
1	7720	Locking door kit
1	BB48	Contoured Bin Shelving Unit
1	SB48-3	Contoured Shelving Unit with Dividers

PACKAGES

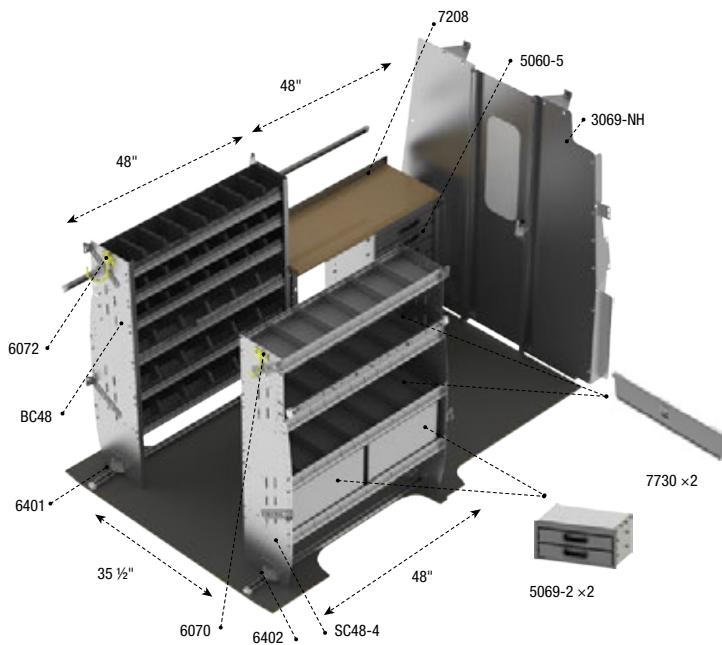

K117

WorkStation Package

Aluminum

146"	472 lbs	8 hrs
High	No	

Qty Part # Description

1	3069-NH	Straight Partition with Tempered Glass Window, Swing Door
1	5060-5	5 Drawer cabinet
2	5069-2	2 Drawer cabinet
1	6070	6" Hook, 3" opening, painted
1	6072	8" Swivel Hook, 4" opening, painted
1	6401	Shelving install track kit, driver side
1	6402	Shelving install track kit, passenger side
1	7208	Workbench w/hardwood top, one end panel
2	7730	Locking door kit
1	BC48	Contoured Bin Shelving Unit
1	SC48-4	Contoured Shelving Unit with Dividers

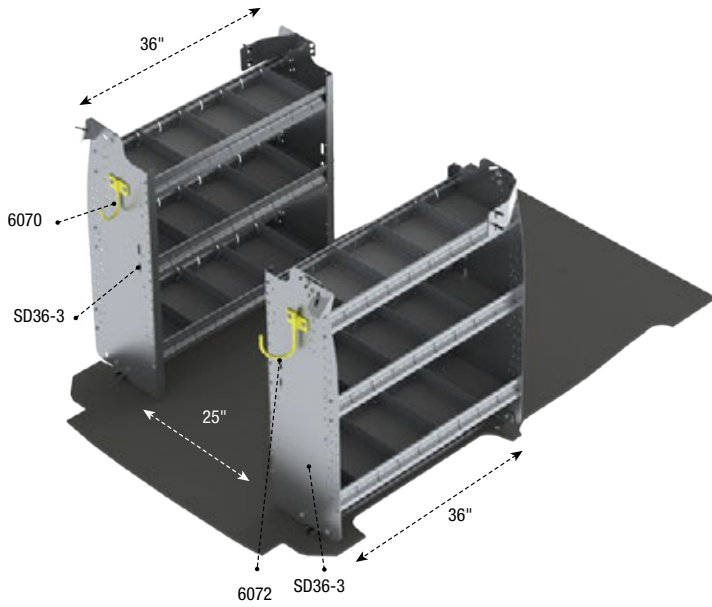

W010

Contractor Package

Aluminum

115"	73 lbs	2 hrs
Standard	Yes	

Qty	Part #	Description
1	6070	6" Hook, 3" opening, painted
1	6072	8" Swivel Hook, 4" opening, painted
2	SD36-3	Contoured Shelving Unit with Dividers

Drill-free installation

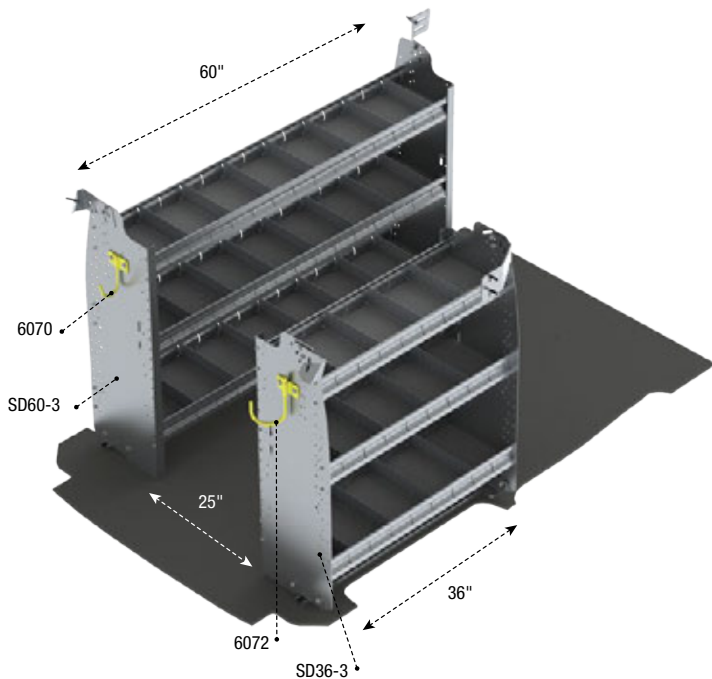

W110

Deluxe Contractor Package

Aluminum

115"	89 lbs	2 hrs
Standard	Yes	

Qty	Part #	Description
1	6070	6" Hook, 3" opening, painted
1	6072	8" Swivel Hook, 4" opening, painted
1	SD36-3	Contoured Shelving Unit with Dividers
1	SD60-3	Contoured Shelving Unit with Dividers

Drill-free installation



NISSAN
NV200

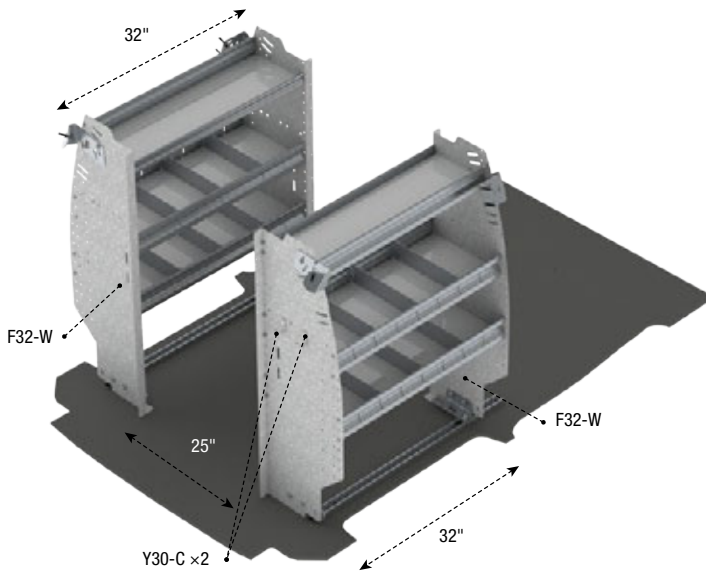

Z10-BW

Base Contractor Package

Steel

115"	96 lbs	2.4 hrs
Standard	Yes	

Qty	Part #	Description
2	F32-W	Contoured Shelving Unit with Dividers
2	Y30-C	Coat Hook, 1" opening, chrome plated

Drill-free installation

PACKAGES

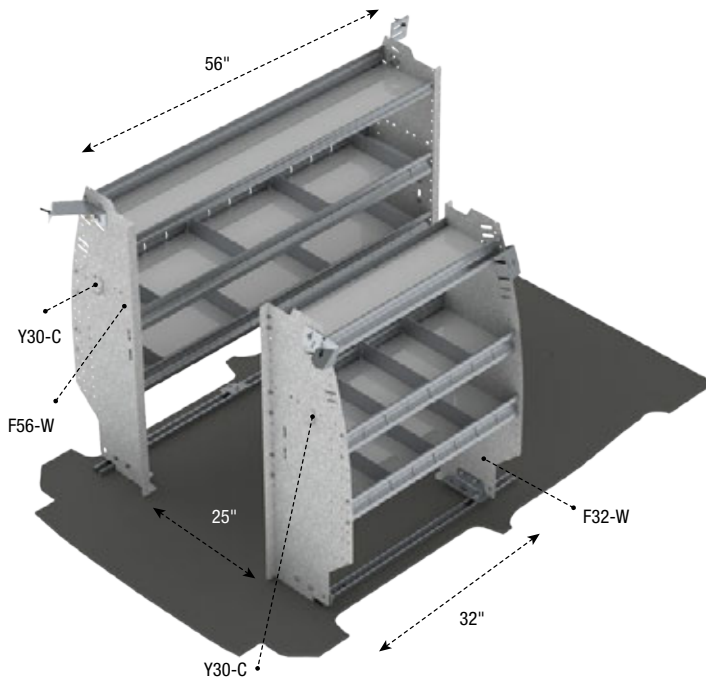

Z10-DW

Deluxe Contractor Package

Steel

115"	114 lbs	2.4 hrs
Standard	Yes	

Qty	Part #	Description
1	F32-W	Contoured Shelving Unit with Dividers
1	F56-W	Contoured Shelving Unit with Dividers
2	Y30-C	Coat Hook, 1" opening, chrome plated

Drill-free installation

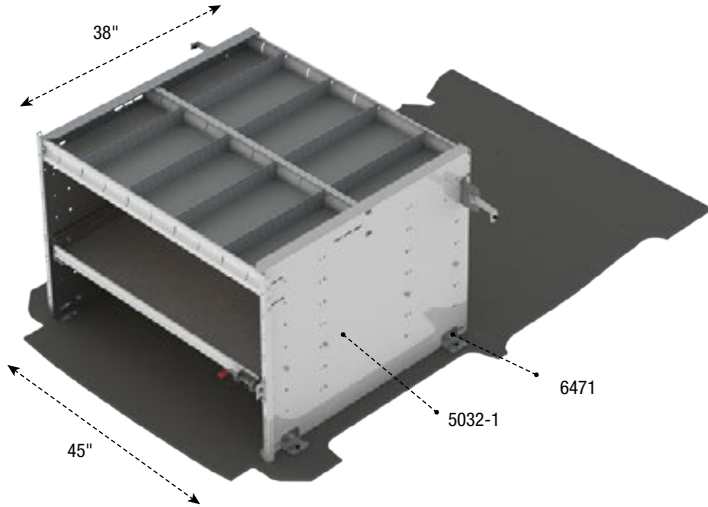

W019

Delivery Package

Aluminum

115"	89 lbs	1 hr
Standard	Yes	

Qty	Part #	Description
1	5032-1	Access Tray with 1 shelf / 1 drawer
1	6471	Access Tray install kit

Drill-free installation

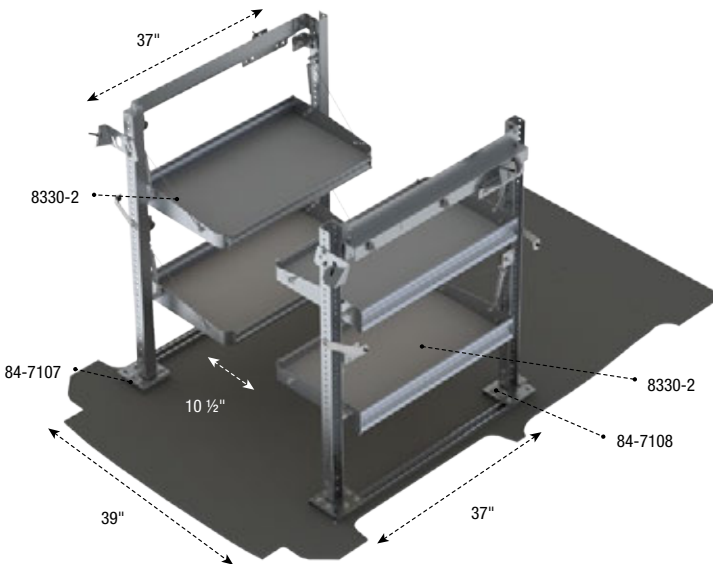

W119

Deluxe Delivery Package

Aluminum

115"	90 lbs	4.8 hrs
Standard	Yes	

Qty	Part #	Description
2	8330-2	Fold-Away Shelving
1	84-7107	Fold-Away shelving install kit, driver side
1	84-7108	Fold-Away shelving install kit, passenger side

Drill-free installation



NISSAN
NV200

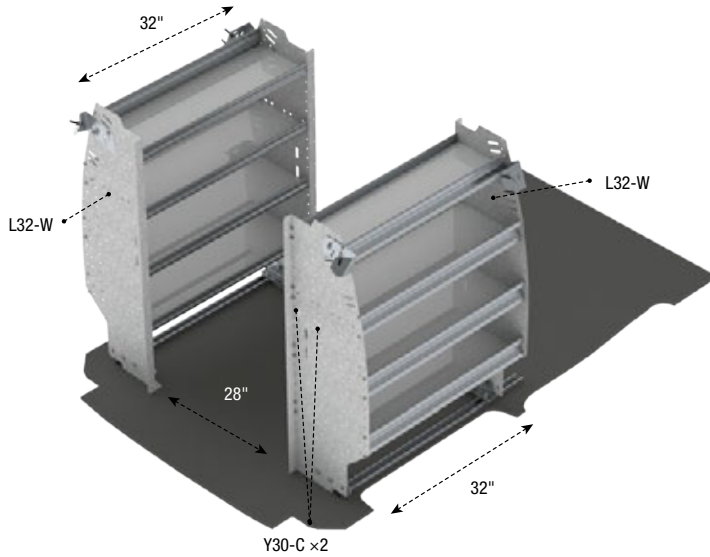

Z19-BW

Delivery Package

Steel

115"	110 lbs	2.4 hrs
Standard	Yes	

Qty	Part #	Description
2	L32-W	Contoured Shelving Unit
2	Y30-C	Coat Hook, 1" opening, chrome plated

Drill-free installation

PACKAGES

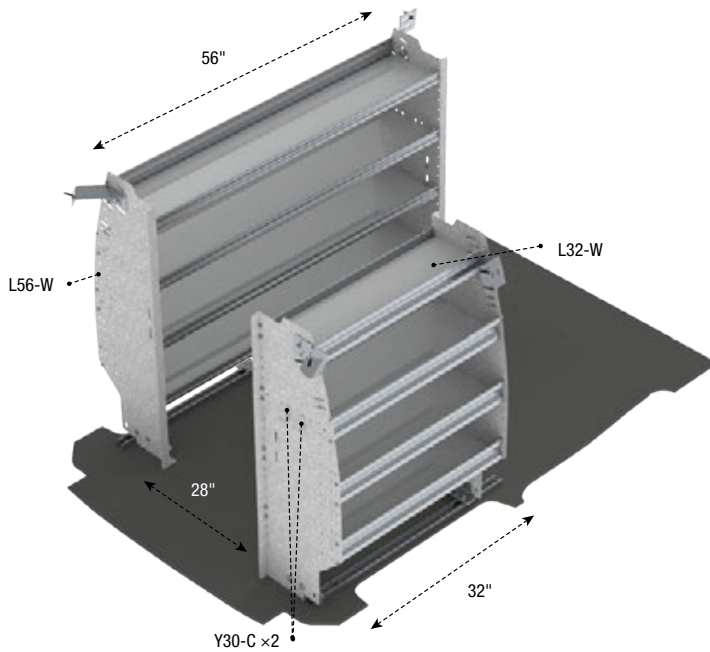

Z19-DW

Deluxe Delivery Package

Steel

115"	133 lbs	2.4 hrs
Standard	Yes	

Qty	Part #	Description
1	L32-W	Contoured Shelving Unit
1	L56-W	Contoured Shelving Unit
2	Y30-C	Coat Hook, 1" opening, chrome plated

Drill-free installation

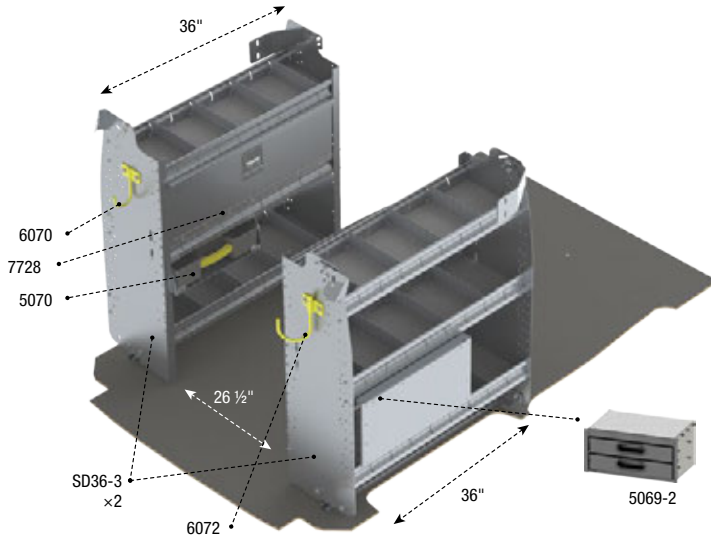

W011

Electrical Package

Aluminum

115"	120 lbs	3.3 hrs
Standard	Yes	

Qty	Part #	Description
1	5069-2	2 Drawer cabinet
1	5070	Partskeeper carry case with holder, universal
1	6070	6" Hook, 3" opening, painted
1	6072	8" Swivel Hook, 4" opening, painted
1	7728	Locking door kit
2	SD36-3	Contoured Shelving Unit with Dividers

Drill-free installation

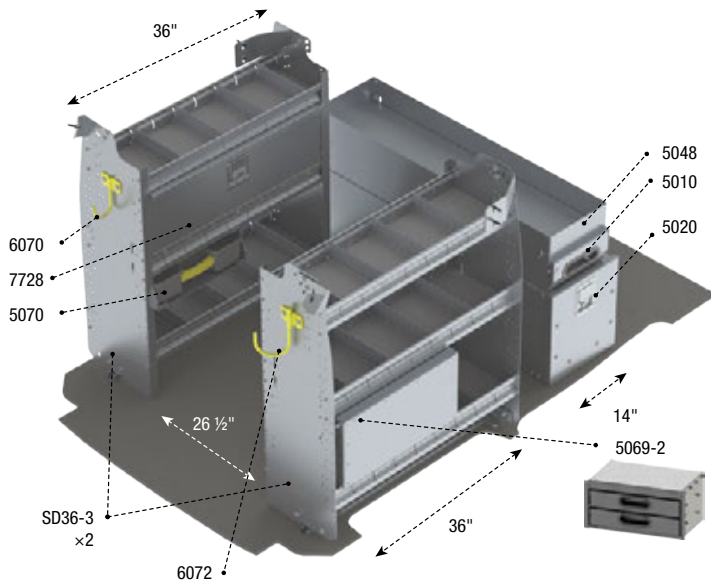

W111

Deluxe Electrical Package

Aluminum

115"	201 lbs	5 hrs
Standard	Yes	

Qty	Part #	Description
1	5010	Partslider drawer
1	5020	Tool drawer
1	5048	Top edge, for 5010 Partslider
1	5069-2	2 Drawer cabinet
1	5070	Partskeeper carry case with holder, universal
1	6070	6" Hook, 3" opening, painted
1	6072	8" Swivel Hook, 4" opening, painted
1	7728	Locking door kit
2	SD36-3	Contoured Shelving Unit with Dividers

Drill-free installation except for the drawers that are not a drill-free installation.



NISSAN
NV200

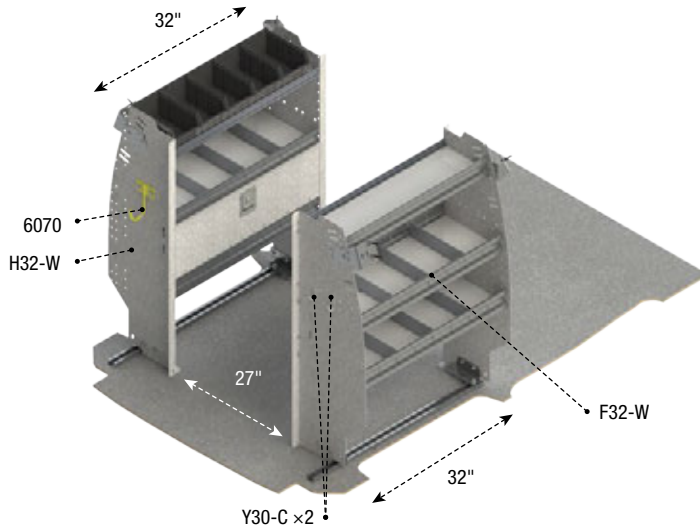

Z11-BW

Base Electrical Package

Steel

115"	107 lbs	2.6 hrs
Standard	Yes	

Qty	Part #	Description
1	6070	6" Hook, 3" opening, painted
1	F32-W	Contoured Shelving Unit with Dividers
1	H32-W	Contoured Bin Shelving Unit
2	Y30-C	Coat Hook, 1" opening, chrome plated

Drill-free installation

PACKAGES

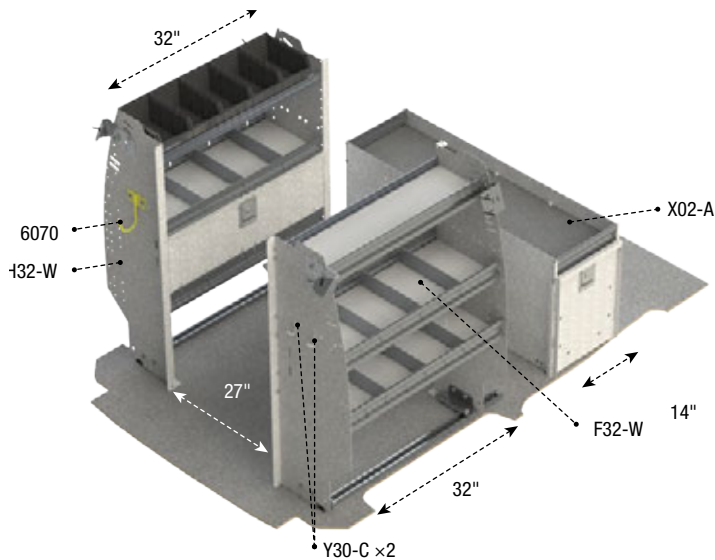

Z11-DW

Deluxe Electrical Package

Steel

115"	187 lbs	3.6 hrs
Standard	Yes	

Qty	Part #	Description
1	6070	6" Hook, 3" opening, painted
1	F32-W	Contoured Shelving Unit with Dividers
1	H32-W	Contoured Bin Shelving Unit
1	X02-A	Fleetline Tool Drawer
2	Y30-C	Coat Hook, 1" opening, chrome plated

Drill-free installation except for the drawers that are not a drill-free installation.

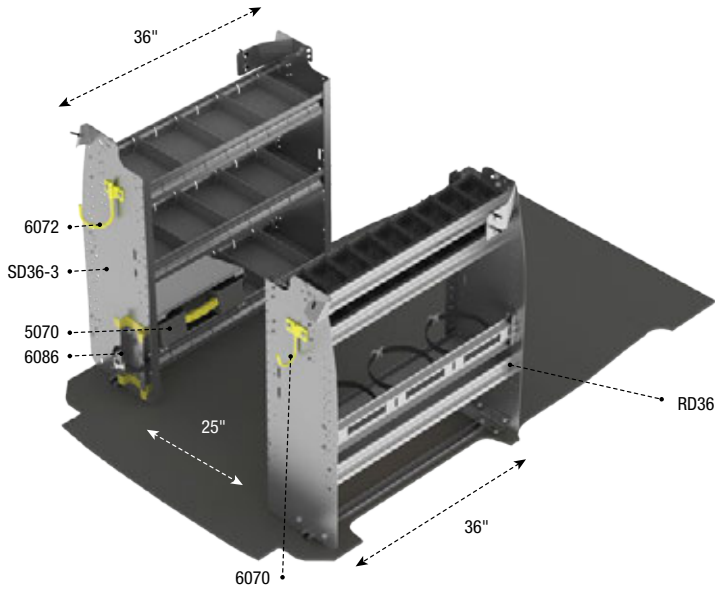

W012

HVAC Package

Aluminum



115"



73 lbs



3 hrs



Standard



No

Qty	Part #	Description
1	5070	Partskeeper carry case with holder, universal
1	6070	6" Hook, 3" opening, painted
1	6072	8" Swivel Hook, 4" opening, painted
1	6086	Small aluminum bottle holder, with a black nylon strap
1	RD36	Contoured Refrigerant Bin Unit
1	SD36-3	Contoured Shelving Unit with Dividers

Drill-free installation

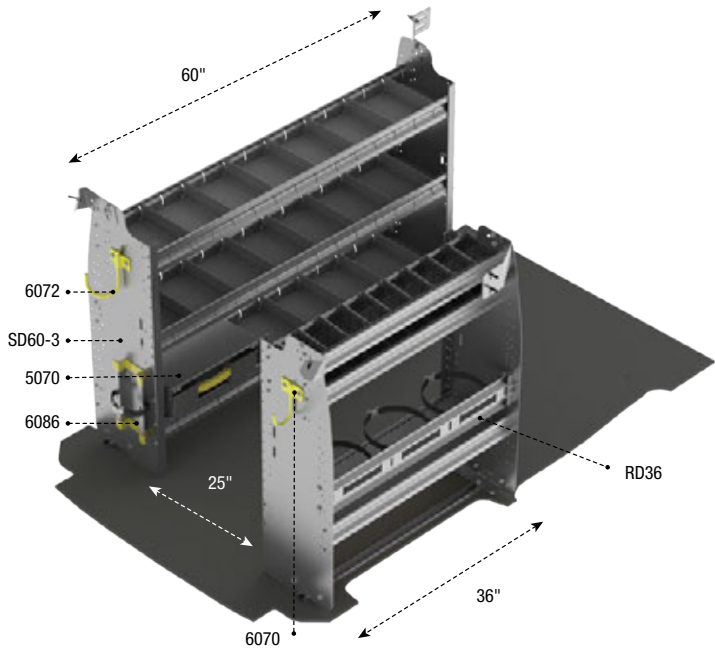

W112

Deluxe HVAC Package

Aluminum



115"



89 lbs



3 hrs



Standard



No

Qty	Part #	Description
1	5070	Partskeeper carry case with holder, universal
1	6070	6" Hook, 3" opening, painted
1	6072	8" Swivel Hook, 4" opening, painted
1	6086	Small aluminum bottle holder, with a black nylon strap
1	RD36	Contoured Refrigerant Bin Unit
1	SD60-3	Contoured Shelving Unit with Dividers

Drill-free installation



NISSAN
NV200

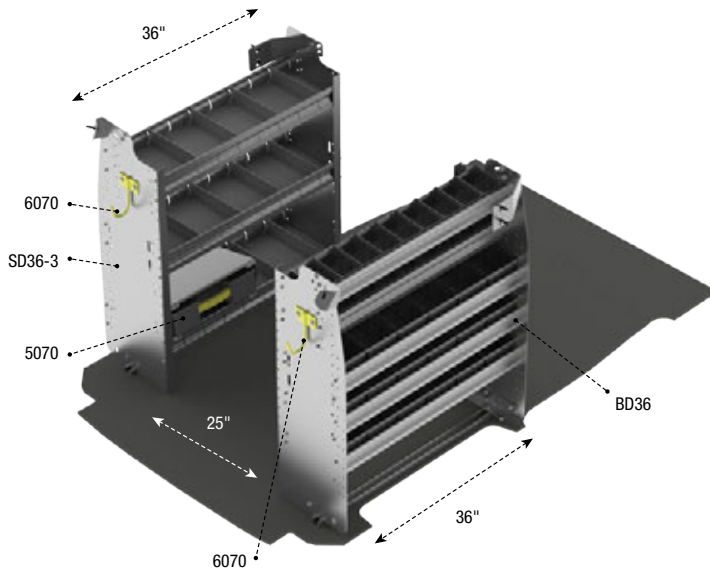

W016

Service Package

Aluminum

115"	93 lbs	2.5 hrs
Standard	Yes	

Qty	Part #	Description
1	5070	Partskeeper carry case with holder, universal
2	6070	6" Hook, 3" opening, painted
1	BD36	Contoured Bin Shelving Unit
1	SD36-3	Contoured Shelving Unit with Dividers

Drill-free installation

PACKAGES

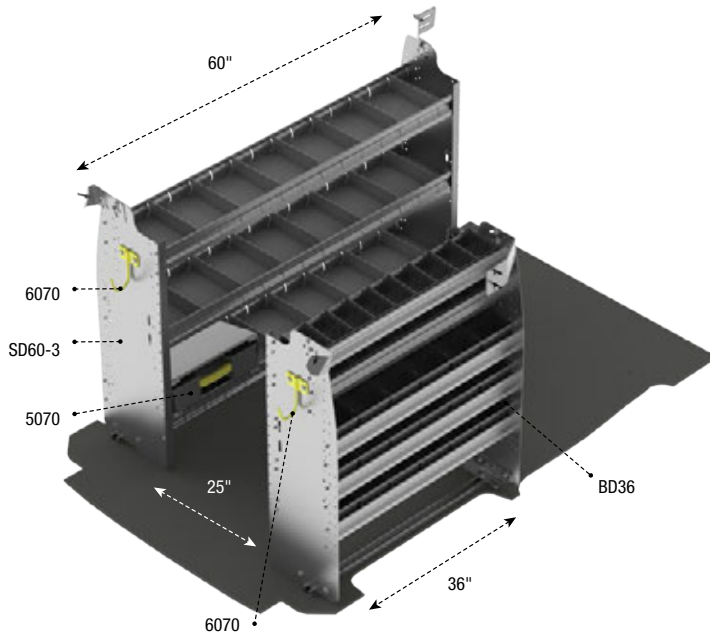

W116

Deluxe Service Package

Aluminum

115"	109 lbs	2.5 hrs
Standard	Yes	

Qty	Part #	Description
1	5070	Partskeeper carry case with holder, universal
2	6070	6" Hook, 3" opening, painted
1	BD36	Contoured Bin Shelving Unit
1	SD60-3	Contoured Shelving Unit with Dividers

Drill-free installation

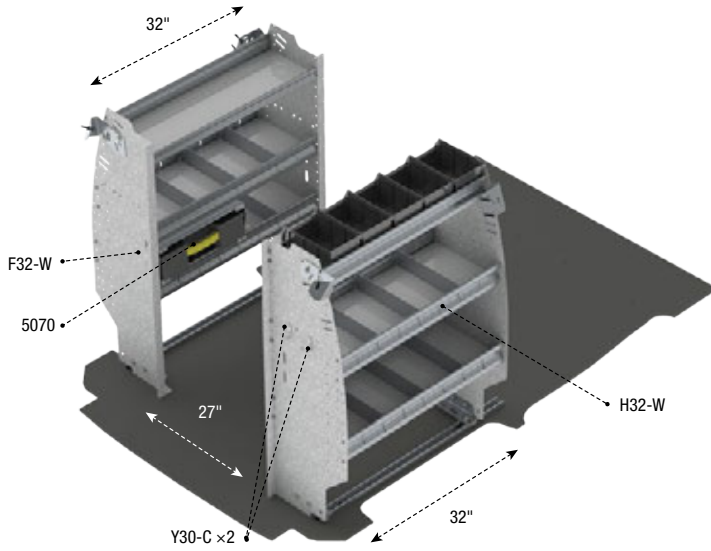

Z16-BW

Base Service Package

Steel

115"	113 lbs	2.7 hrs
Standard	Yes	

Qty	Part #	Description
1	5070	Partskeeper carry case with holder, universal
1	F32-W	Contoured Shelving Unit with Dividers
1	H32-W	Contoured Bin Shelving Unit
2	Y30-C	Coat Hook, 1" opening, chrome plated

Drill-free installation

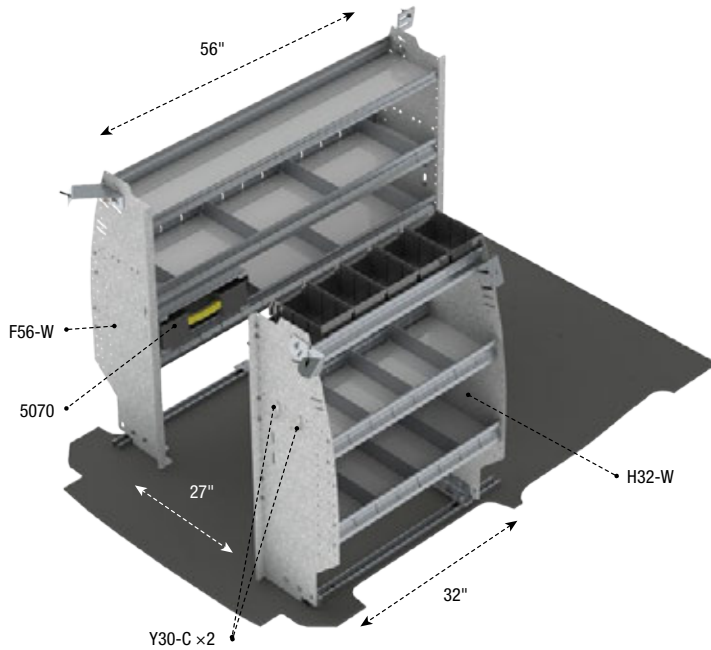

Z16-DW

Deluxe Service Package

Steel

115"	131 lbs	2.7 hrs
Standard	Yes	

Qty	Part #	Description
1	5070	Partskeeper carry case with holder, universal
1	F56-W	Contoured Shelving Unit with Dividers
1	H32-W	Contoured Bin Shelving Unit
2	Y30-C	Coat Hook, 1" opening, chrome plated

Drill-free installation

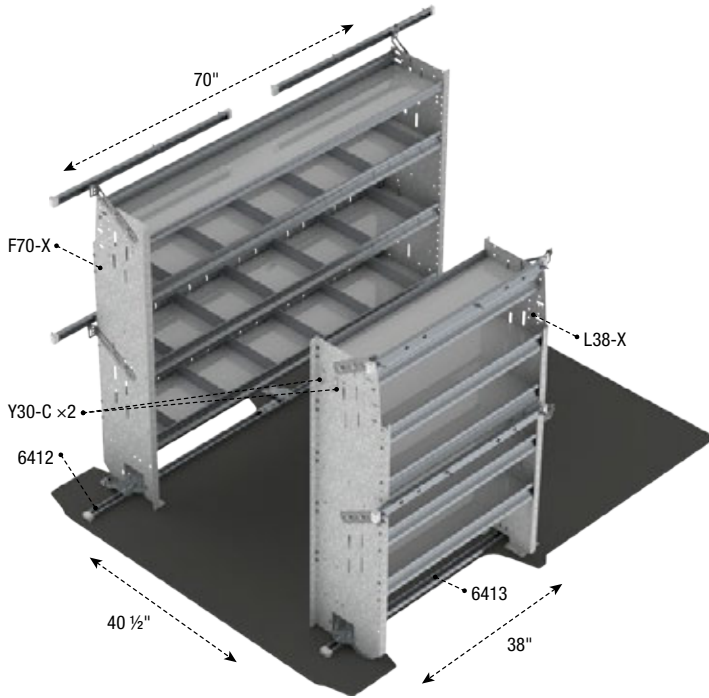

Z10-E0

Base Contractor Package

Steel

118"	201 lbs	2.4 hrs
Standard	Yes	

Qty	Part #	Description
1	6412	Shelving install kit, driver side
1	6413	Shelving install kit, passenger side
1	F70-X	Square Back Shelving Unit with Dividers
1	L38-X	Square Back Shelving Unit
2	Y30-C	Coat Hook, 1" opening, chrome plated

PACKAGES

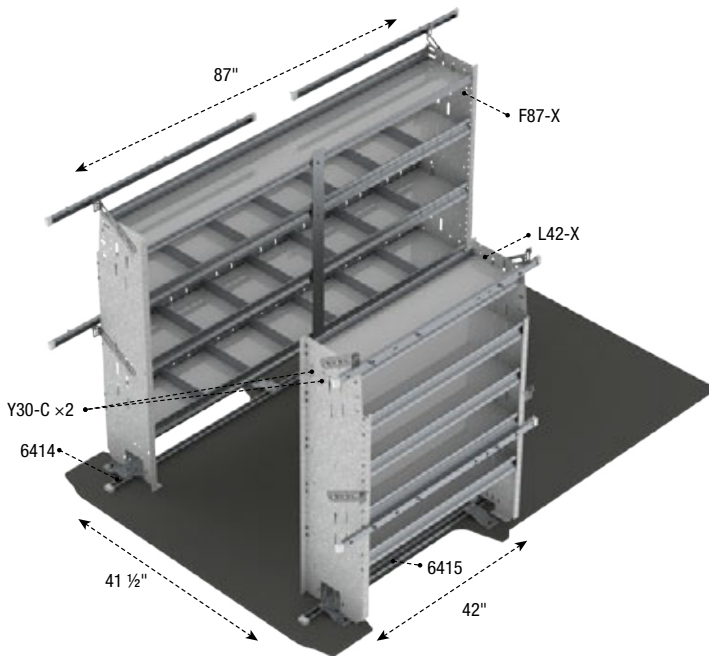

Z10-E1

Base Contractor Package

Steel

136"	231 lbs	2.4 hrs
Standard / High	Yes	

Qty	Part #	Description
1	6414	Shelving install kit, driver side
1	6415	Shelving install kit, passenger side
1	F87-X	Square Back Shelving Unit with Dividers
1	L42-X	Square Back Shelving Unit
2	Y30-C	Coat Hook, 1" opening, chrome plated



Z10-E1

Contractor Package

Efficient layout helps you save money, prevent injury and increase payload.



QUIET

The combination of the extrusion, shelf tray, and end-panels create durable, vibration-free shelves.



EFFICIENT

Ergonomic design reduces injuries and increases productivity.



TOUGH

Extrusion builds durability into shelf.

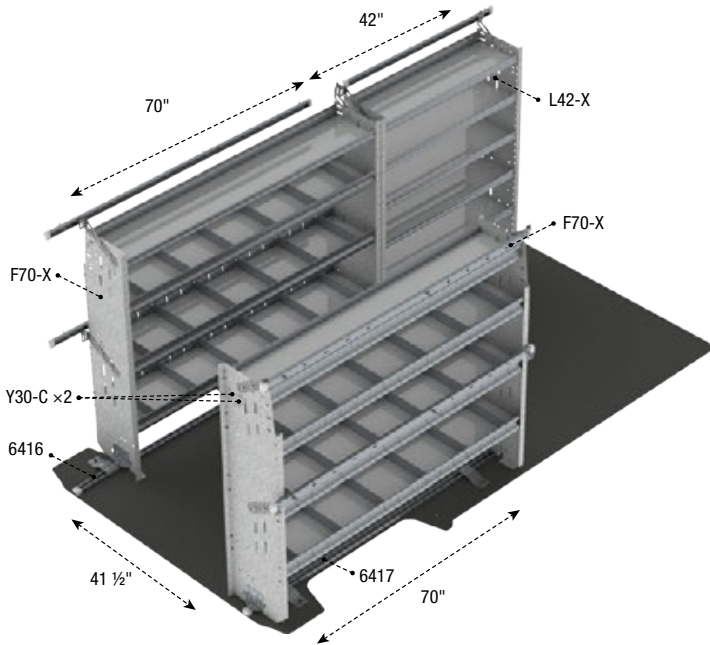

Z10-E2

Base Contractor Package

Steel

159"	316 lbs	3.4 hrs
High	Yes	

Qty	Part #	Description
1	6416	Shelving install kit, driver side
1	6417	Shelving install kit, passenger side
2	F70-X	Square Back Shelving Unit with Dividers
1	L42-X	Square Back Shelving Unit
2	Y30-C	Coat Hook, 1" opening, chrome plated

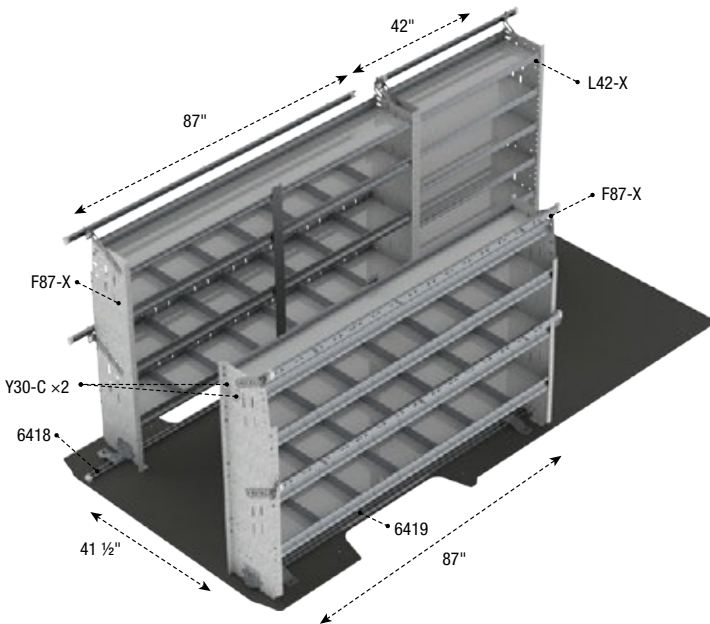

Z10-E3

Base Contractor Package

Steel

159" Ext	365 lbs	3.4 hrs
High	Yes	

Qty	Part #	Description
1	6418	Shelving install kit, driver side
1	6419	Shelving install kit, passenger side
2	F87-X	Square Back Shelving Unit with Dividers
1	L42-X	Square Back Shelving Unit
2	Y30-C	Coat Hook, 1" opening, chrome plated

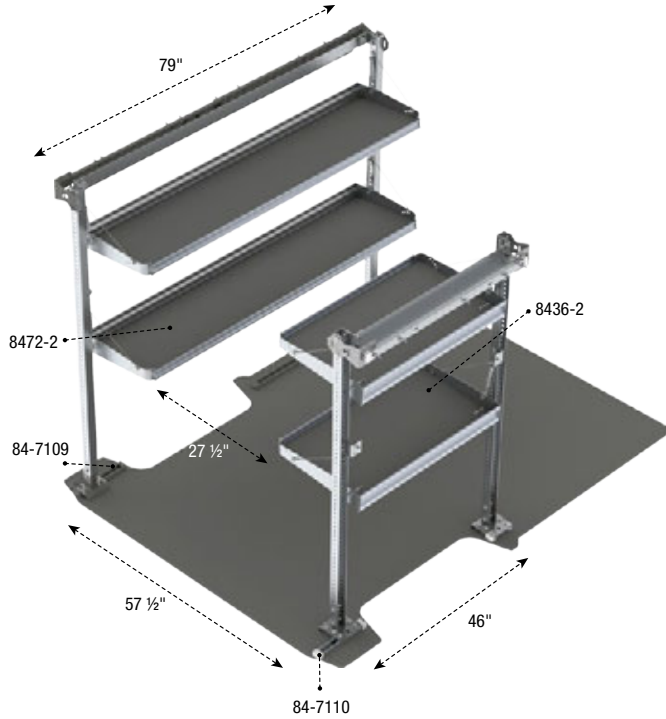

E019

Delivery Package

Aluminum

118"	148 lbs	4.6 hrs
Standard	Yes	

Qty	Part #	Description
1	84-7109	Fold-Away install kit, driver side
1	84-7110	Fold-Away install kit, passenger side
1	8436-2	Fold-Away Shelving
1	8472-2	Fold-Away Shelving

PACKAGES

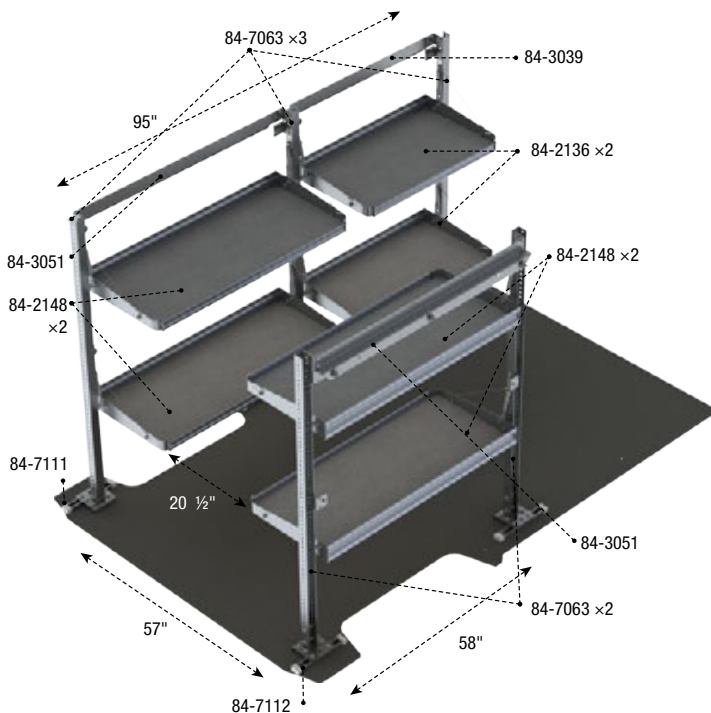

E119

Delivery Package

Aluminum

136"	184 lbs	6.6 hrs
Standard / High	Yes	

Qty	Part #	Description
2	84-2136	Fold-Away Shelf Tray with Gas Shocks and Hardware
4	84-2148	Fold-Away Shelf Tray with Gas Shocks and Hardware
1	84-3039	Mounting Bar Assembly for Fold-Away Shelving
2	84-3051	Mounting Bar Assembly for Fold-Away Shelving
5	84-7063	Post Assembly for Fold-Away Shelving
1	84-7111	Fold-Away install kit, driver side
1	84-7112	Fold-Away install kit, passenger side

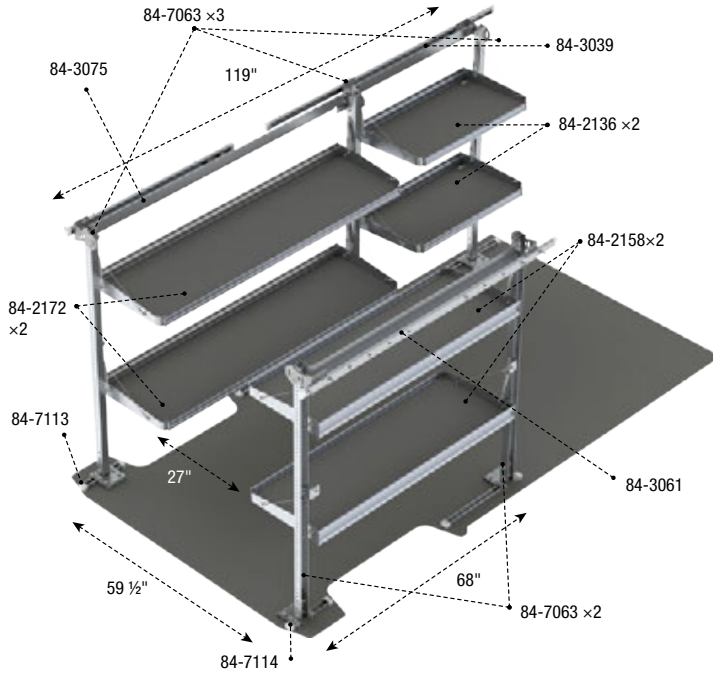

E219

Delivery Package

Aluminum

159"

215 lbs

6.8 hrs

High

Yes

Qty	Part #	Description
2	84-2136	Fold-Away Shelf Tray with Gas Shocks and Hardware
2	84-2158	Fold-Away Shelf Tray with Gas Shocks and Hardware
2	84-2172	Fold-Away Shelf Tray with Gas Shocks and Hardware
1	84-3039	Mounting Bar Assembly for Fold-Away Shelving
1	84-3061	Mounting Bar Assembly for Fold-Away Shelving
1	84-3075	Mounting Bar Assembly for Fold-Away Shelving
5	84-7063	Post Assembly for Fold-Away Shelving
1	84-7113	Fold-Away install kit, driver side
1	84-7114	Fold-Away install kit, passenger side

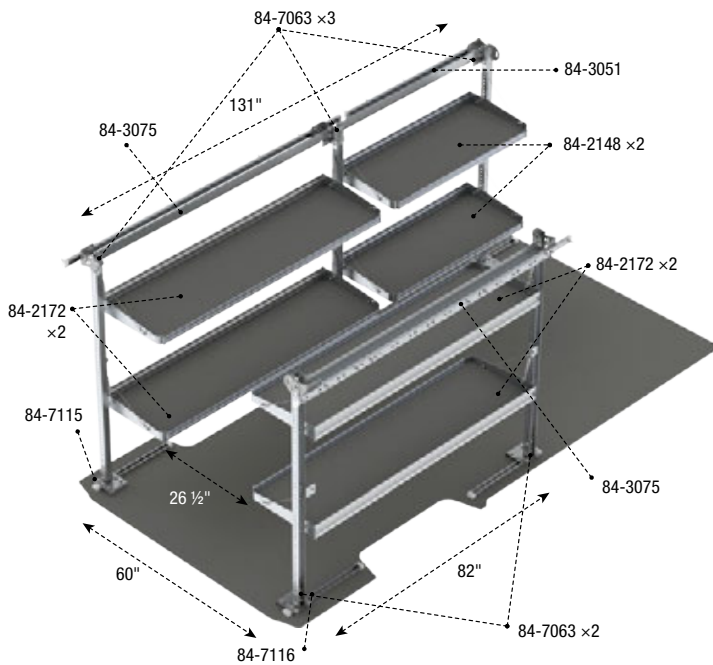

E319

Delivery Package

Aluminum

159" Ext

236 lbs

6.8 hrs

High

Yes

Qty	Part #	Description
2	84-2148	Fold-Away Shelf Tray with Gas Shocks and Hardware
4	84-2172	Fold-Away Shelf Tray with Gas Shocks and Hardware
1	84-3051	Mounting Bar Assembly for Fold-Away Shelving
2	84-3075	Mounting Bar Assembly for Fold-Away Shelving
5	84-7063	Post Assembly for Fold-Away Shelving
1	84-7115	Fold-Away install kit, driver side
1	84-7116	Fold-Away install kit, passenger side

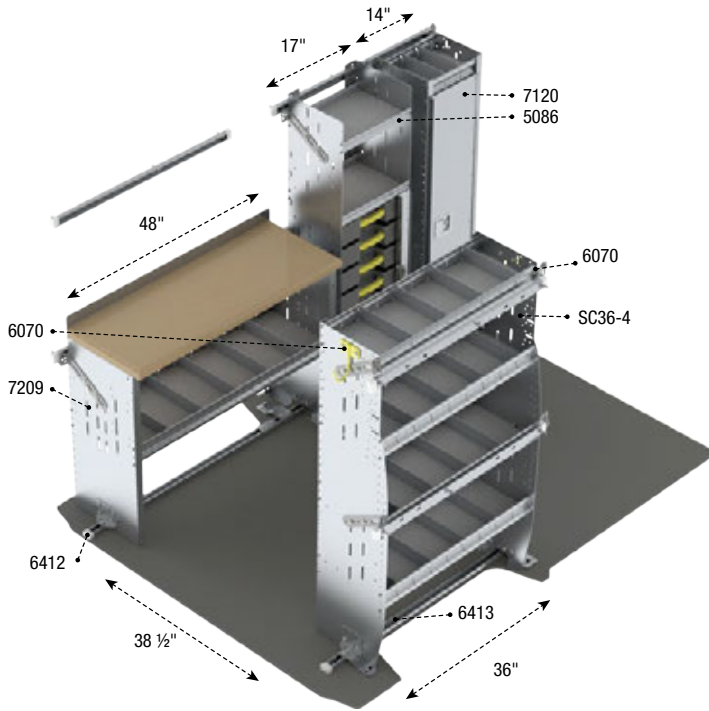

E011

Electrical Package

Aluminum

118"	225 lbs	4.6 hrs
Standard	Yes	

Qty	Part #	Description
1	5086	Partskeeper cabinet with 8 carry cases & 2 shelves
2	6070	6" Hook, 3" opening, painted
1	6412	Shelving install kit, driver side
1	6413	Shelving install kit, passenger side
1	7120	Locker w/top shelf
1	7209	Workbench w/hardwood top, 1 shelf
1	SC36-4	Contoured Shelving Unit with Dividers

PACKAGES

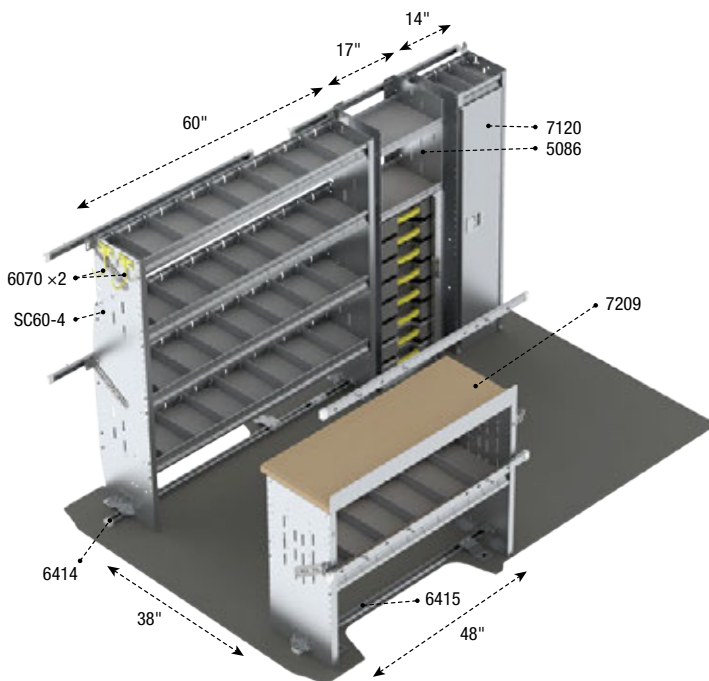

E111

Electrical Package

Aluminum

136"	248 lbs	4.6 hrs
Standard / High	Yes	

Qty	Part #	Description
1	5086	Partskeeper cabinet with 8 carry cases & 2 shelves
2	6070	6" Hook, 3" opening, painted
1	6414	Shelving install kit, driver side
1	6415	Shelving install kit, passenger side
1	7120	Locker w/top shelf
1	7209	Workbench w/hardwood top, 1 shelf
1	SC60-4	Contoured Shelving Unit with Dividers

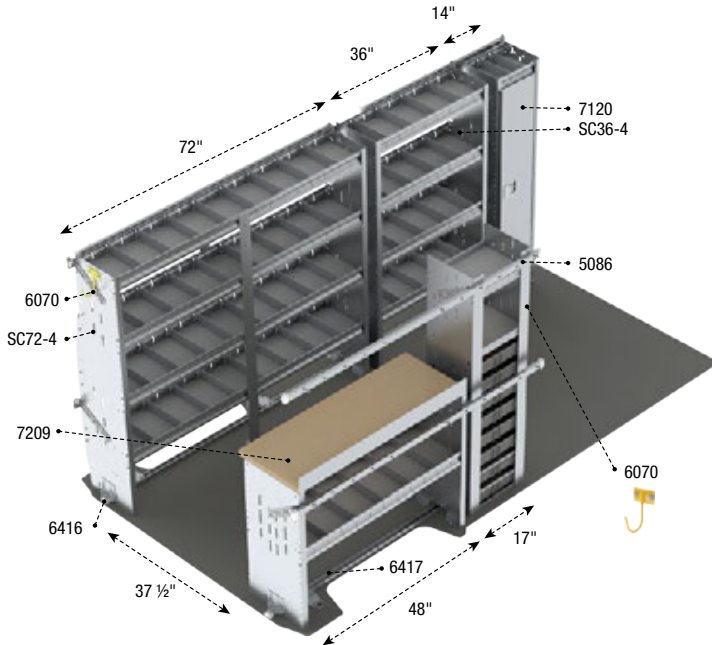

E211

Electrical Package

Aluminum

159"

310 lbs

6 hrs

High

Yes

Qty	Part #	Description
1	5086	Partskeeper cabinet with 8 carry cases & 2 shelves
2	6070	6" Hook, 3" opening, painted
1	6416	Shelving install kit, driver side
1	6417	Shelving install kit, passenger side
1	7120	Locker w/top shelf
1	7209	Workbench w/hardwood top, 1 shelf
1	SC36-4	Contoured Shelving Unit with Dividers
1	SC72-4	Contoured Shelving Unit with Dividers

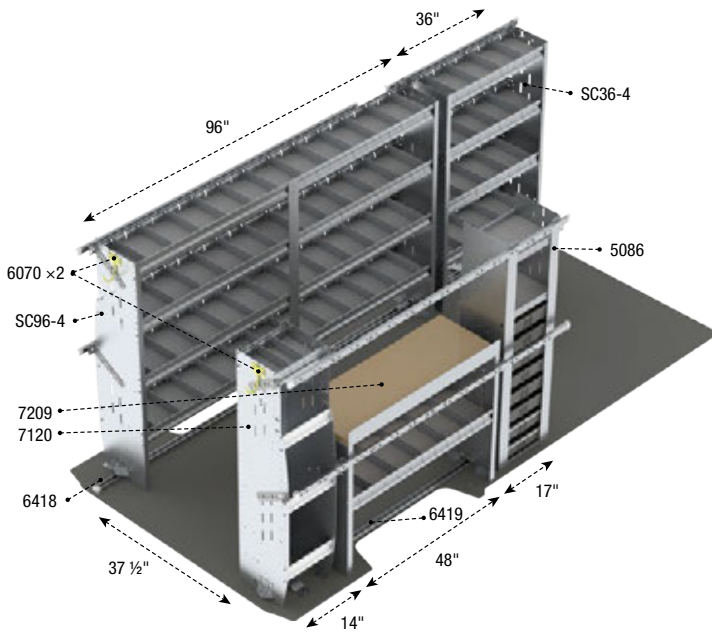

E311

Electrical Package

Aluminum

159" Ext

335 lbs

6 hrs

High

Yes

Qty	Part #	Description
1	5086	Partskeeper cabinet with 8 carry cases & 2 shelves
2	6070	6" Hook, 3" opening, painted
1	6418	Shelving install kit, driver side
1	6419	Shelving install kit, passenger side
1	7120	Locker w/top shelf
1	7209	Workbench w/hardwood top, 1 shelf
1	SC36-4	Contoured Shelving Unit with Dividers
1	SC96-4	Contoured Shelving Unit with Dividers

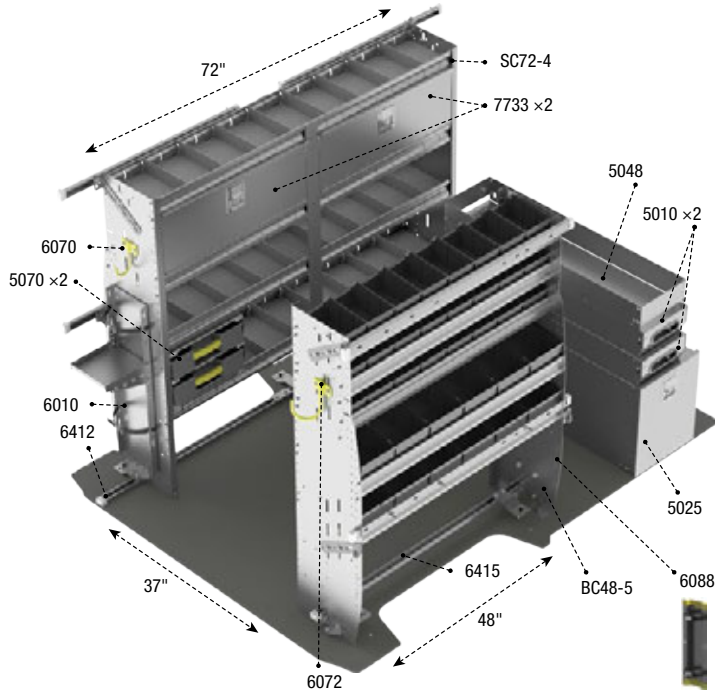

E012

HVAC Package

Aluminum

118"	347 lbs	7.6 hrs
Standard	No	

Qty	Part #	Description
2	5010	Partslider drawer
1	5025	Jumbo tool drawer
1	5048	Top edge, for 5010 Partslider
2	5070	Partskeeper carry case with holder, universal
1	6010	Two level adjustable bottle holder
1	6070	6" Hook, 3" opening, painted
1	6072	8" Swivel Hook, 4" opening, painted
1	6088	Large aluminum bottle holder, with two black nylon straps
1	6412	Shelving install kit, driver side
1	6415	Shelving install kit, passenger side
2	7733	Locking door kit
1	BC48-5	Contoured Bin Shelving Unit
1	SC72-4	Contoured Shelving Unit with Dividers

PACKAGES

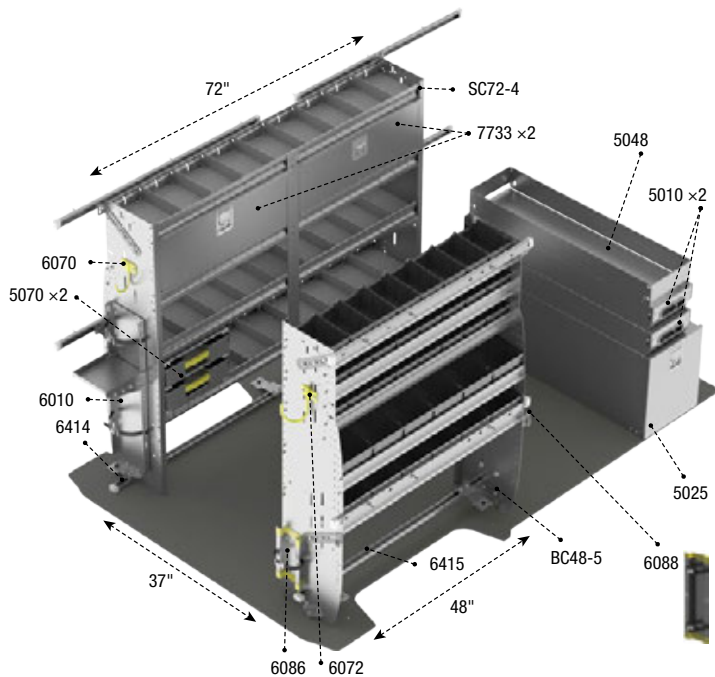

E112

HVAC Package

Aluminum

136"	350 lbs	7.8 hrs
Standard / High	No	

Qty	Part #	Description
2	5010	Partslider drawer
1	5025	Jumbo tool drawer
1	5048	Top edge, for 5010 Partslider
2	5070	Partskeeper carry case with holder, universal
1	6010	Two level adjustable bottle holder
1	6070	6" Hook, 3" opening, painted
1	6072	8" Swivel Hook, 4" opening, painted
1	6086	Small aluminum bottle holder, with a black nylon strap
1	6088	Large aluminum bottle holder, with two black nylon straps
1	6414	Shelving install kit, driver side
1	6415	Shelving install kit, passenger side
2	7733	Locking door kit
1	BC48-5	Contoured Bin Shelving Unit
1	SC72-4	Contoured Shelving Unit with Dividers

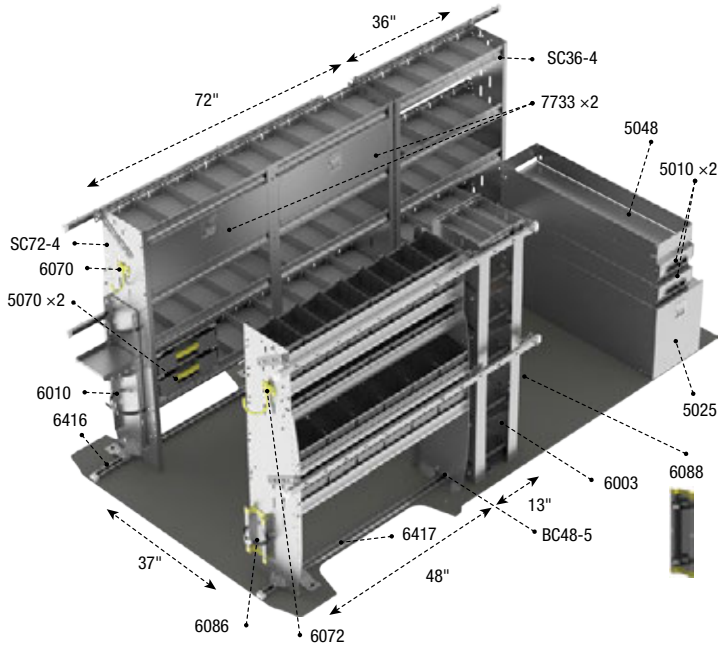

E212

HVAC Package

Aluminum

159"

438 lbs

9.7 hrs

High

No

Qty	Part #	Description
2	5010	Partslider drawer
1	5025	Jumbo tool drawer
1	5048	Top edge, for 5010 Partslider
2	5070	Partskeeper carry case with holder, universal
1	6003	5 Tier refrigerant rack for large bottles
1	6010	Two level adjustable bottle holder
1	6070	6" Hook, 3" opening, painted
1	6072	8" Swivel Hook, 4" opening, painted
1	6086	Small aluminum bottle holder, with a black nylon strap
1	6088	Large aluminum bottle holder, with two black nylon straps
1	6416	Shelving install kit, driver side
1	6417	Shelving install kit, passenger side
2	7733	Locking door kit
1	BC48-5	Contoured Bin Shelving Unit
1	SC36-4	Contoured Shelving Unit with Dividers
1	SC72-4	Contoured Shelving Unit with Dividers

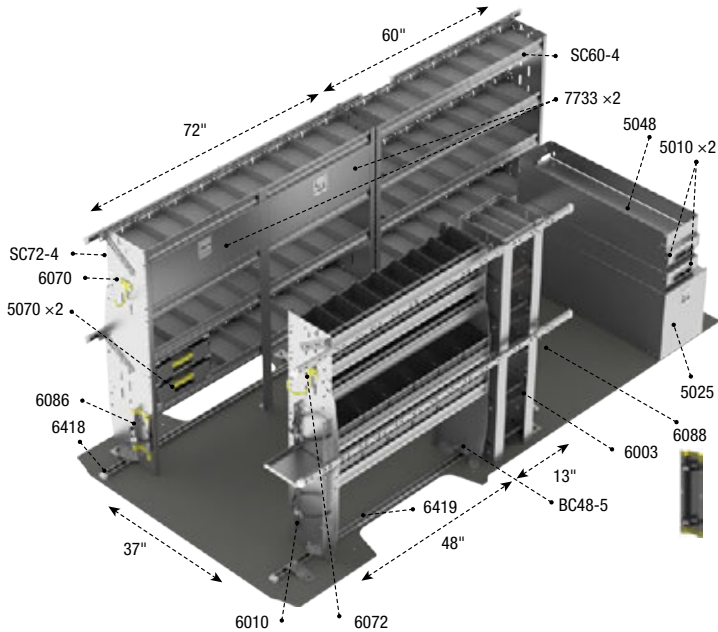

E312

HVAC Package

Aluminum

159" Ext

461 lbs

9.7 hrs

High

No

Qty	Part #	Description
2	5010	Partslider drawer
1	5025	Jumbo tool drawer
1	5048	Top edge, for 5010 Partslider
2	5070	Partskeeper carry case with holder, universal
1	6003	5 Tier refrigerant rack for large bottles
1	6010	Two level adjustable bottle holder
1	6070	6" Hook, 3" opening, painted
1	6072	8" Swivel Hook, 4" opening, painted
1	6086	Small aluminum bottle holder, with a black nylon strap
1	6088	Large aluminum bottle holder, with two black nylon straps
1	6418	Shelving install kit, driver side
1	6419	Shelving install kit, passenger side
2	7733	Locking door kit
1	BC48-5	Contoured Bin Shelving Unit
1	SC60-4	Contoured Shelving Unit with Dividers
1	SC72-4	Contoured Shelving Unit with Dividers

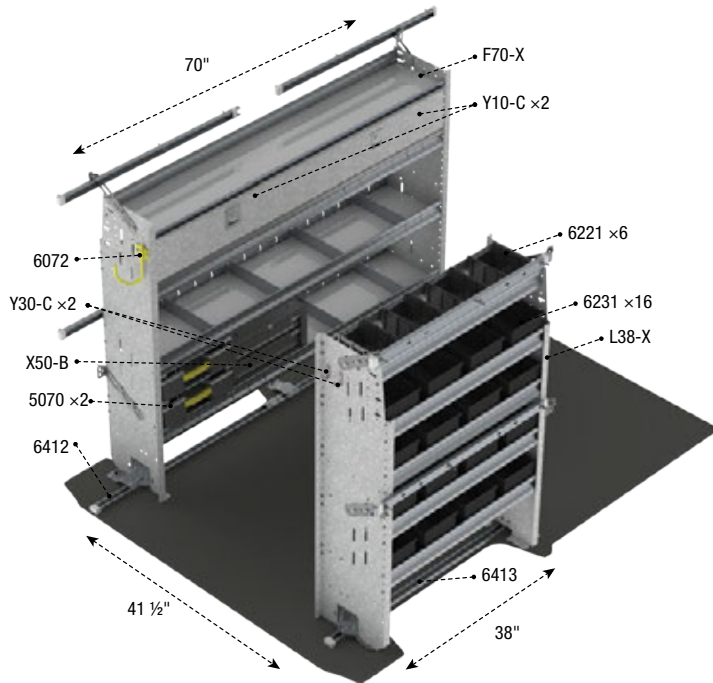

Z16-E0

Service Package

Steel

118"	277 lbs	4.5 hrs
Standard	Yes	

Qty	Part #	Description
2	5070	Partskeeper carry case with holder, universal
1	6072	8" Swivel Hook, 4" opening, painted
6	6221	Medium Bin, Graphite
16	6231	Large Bin, Graphite
1	6412	Shelving install kit, driver side
1	6413	Shelving install kit, passenger side
1	F70-X	Square Back Shelving Unit with Dividers
1	L38-X	Square Back Shelving Unit
1	X50-B	Compact 2-Drawer Unit
2	Y10-C	Locking door kit
2	Y30-C	Coat Hook, 1" opening, chrome plated

PACKAGES

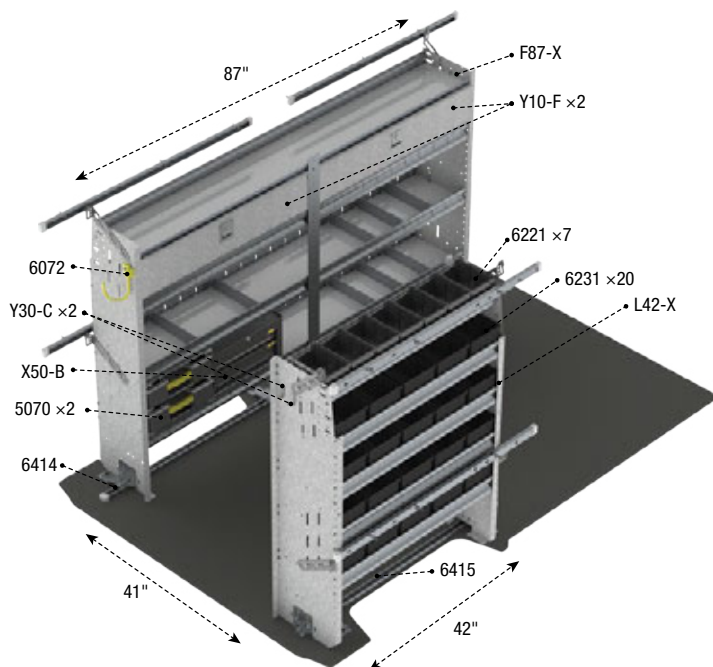

Z16-E1

Service Package

Steel

136"	319 lbs	4.5 hrs
Standard / High	Yes	

Qty	Part #	Description
2	5070	Partskeeper carry case with holder, universal
1	6072	8" Swivel Hook, 4" opening, painted
7	6221	Medium Bin, Graphite
20	6231	Large Bin, Graphite
1	6414	Shelving install kit, driver side
1	6415	Shelving install kit, passenger side
1	F87-X	Square Back Shelving Unit with Dividers
1	L42-X	Square Back Shelving Unit
1	X50-B	Compact 2-Drawer Unit
2	Y10-F	Locking door kit
2	Y30-C	Coat Hook, 1" opening, chrome plated

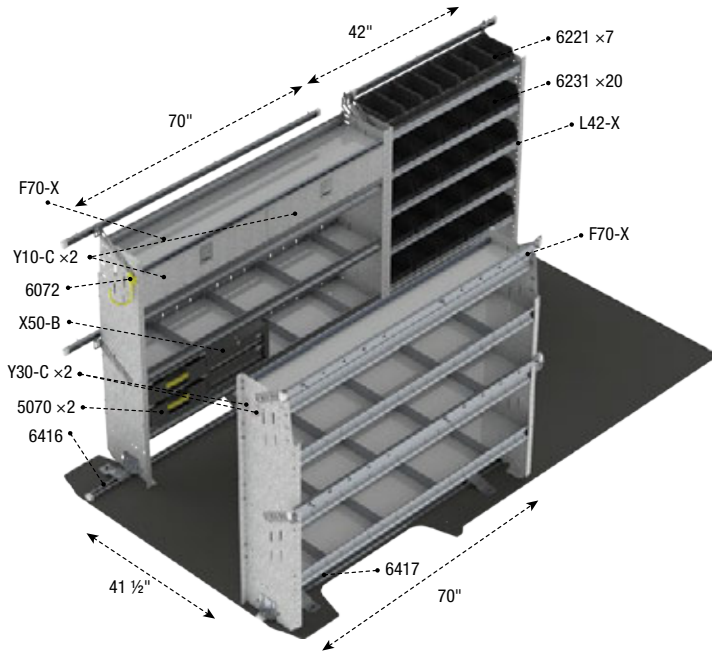

Z16-E2

Service Package

Steel

159"	398 lbs	5.5 hrs
High	Yes	

Qty	Part #	Description
2	5070	Partskeeper carry case with holder, universal
1	6072	8" Swivel Hook, 4" opening, painted
7	6221	Medium Bin, Graphite
20	6231	Large Bin, Graphite
1	6416	Shelving install kit, driver side
1	6417	Shelving install kit, passenger side
2	F70-X	Square Back Shelving Unit with Dividers
1	L42-X	Square Back Shelving Unit
1	X50-B	Compact 2-Drawer Unit
2	Y10-C	Locking door kit
2	Y30-C	Coat Hook, 1" opening, chrome plated

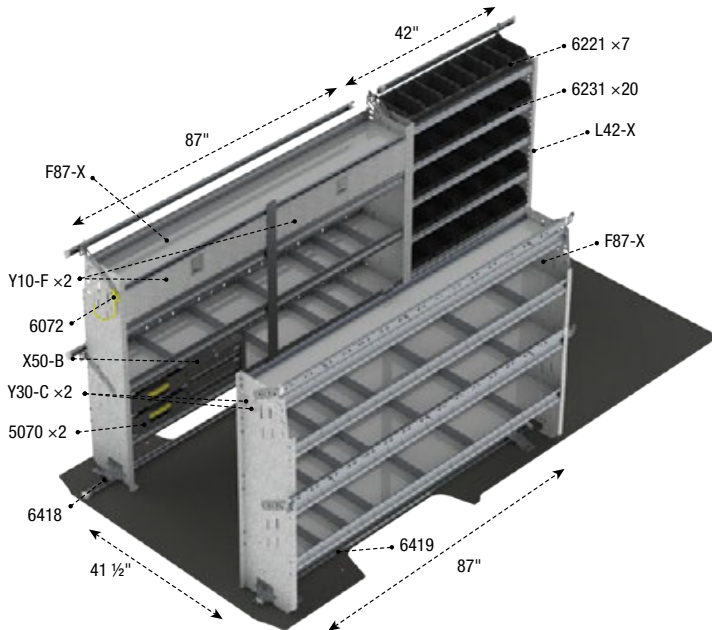

Z16-E3

Service Package

Steel

159" Ext	453 lbs	5.5 hrs
High	Yes	

Qty	Part #	Description
2	5070	Partskeeper carry case with holder, universal
1	6072	8" Swivel Hook, 4" opening, painted
7	6221	Medium Bin, Graphite
20	6231	Large Bin, Graphite
1	6418	Shelving install kit, driver side
1	6419	Shelving install kit, passenger side
2	F87-X	Square Back Shelving Unit with Dividers
1	L42-X	Square Back Shelving Unit
1	X50-B	Compact 2-Drawer Unit
2	Y10-F	Locking door kit
2	Y30-C	Coat Hook, 1" opening, chrome plated

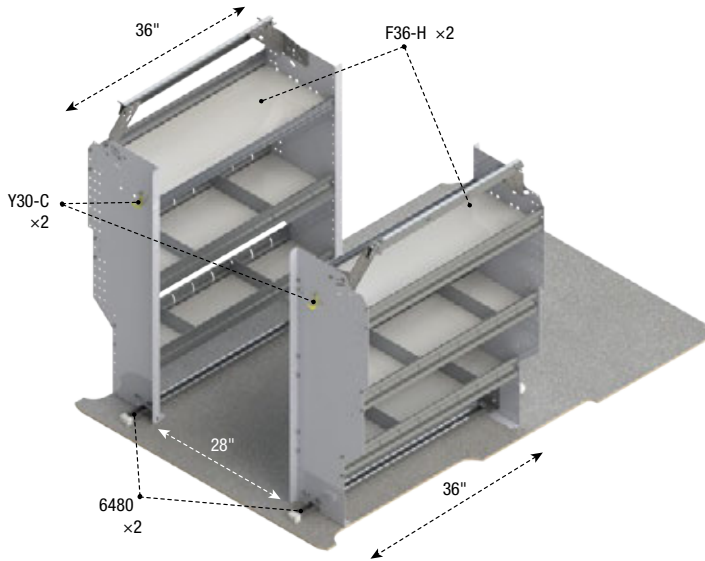

Z10-H3

Base Contractor Package

Steel

122"

98 lbs

2.4 hrs

Standard

Yes

Qty	Part #	Description
2	6480	Shelving install kit
2	F36-H	Contoured Shelving Unit with Dividers
2	Y30-C	Coat Hook, 1" opening, chrome plated

PACKAGES

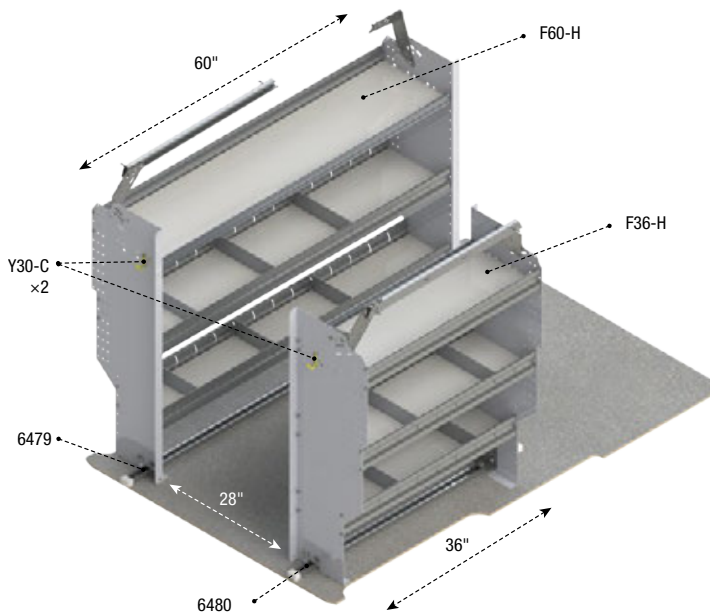

Z10-H4

Deluxe Contractor Package

Steel

122"

110 lbs

2.4 hrs

Standard

Yes

Qty	Part #	Description
1	6479	Shelving install kit
1	6480	Shelving install kit
1	F36-H	Contoured Shelving Unit with Dividers
1	F60-H	Contoured Shelving Unit with Dividers
2	Y30-C	Coat Hook, 1" opening, chrome plated



Z10-H3

Contractor Package

Engineered service packages ensure your vehicle is ready to work fast, no downtime.

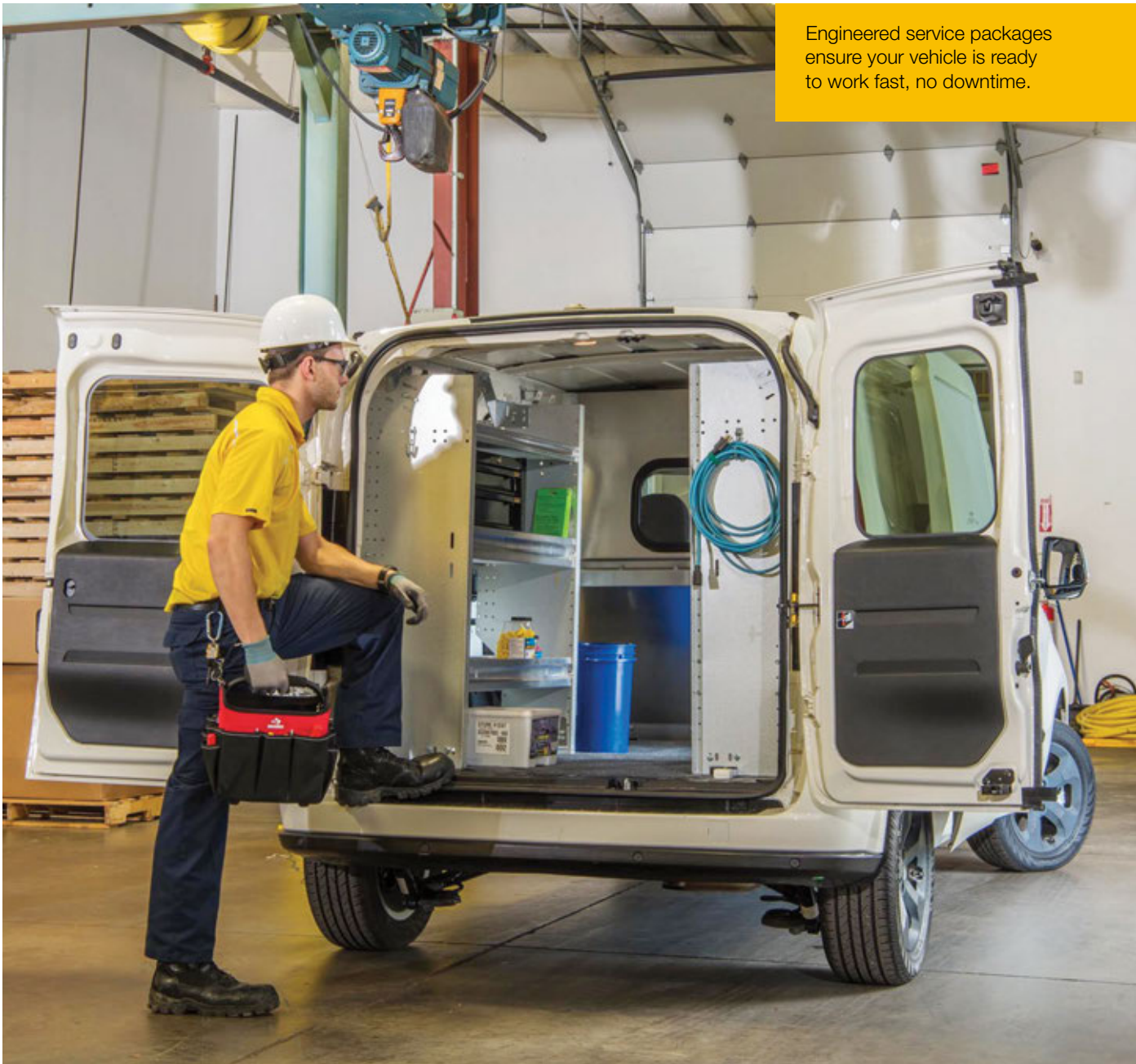

QUIET

The combination of the extrusion, shelf tray, and end-panels create durable, vibration-free shelves.

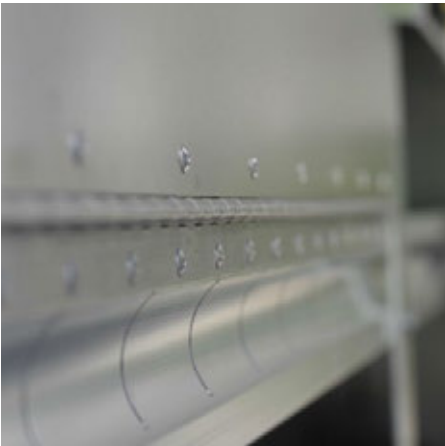

EFFICIENT

Ergonomic design reduces injuries and increases productivity.



TOUGH

Extrusion builds durability into shelf.

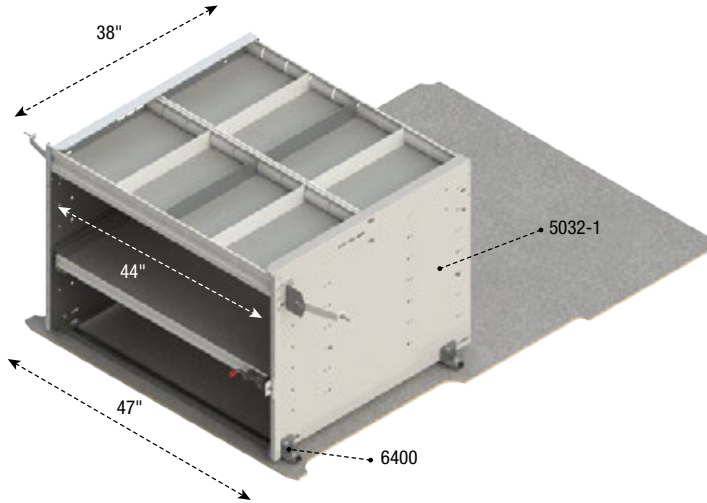

H319

Base Delivery Package

Aluminum

122"	89 lbs	1 hr
Standard	Yes	

Qty	Part #	Description
1	5032-1	Axess Tray with 1 shelf / 1 drawer
1	6400	Axess Tray install kit

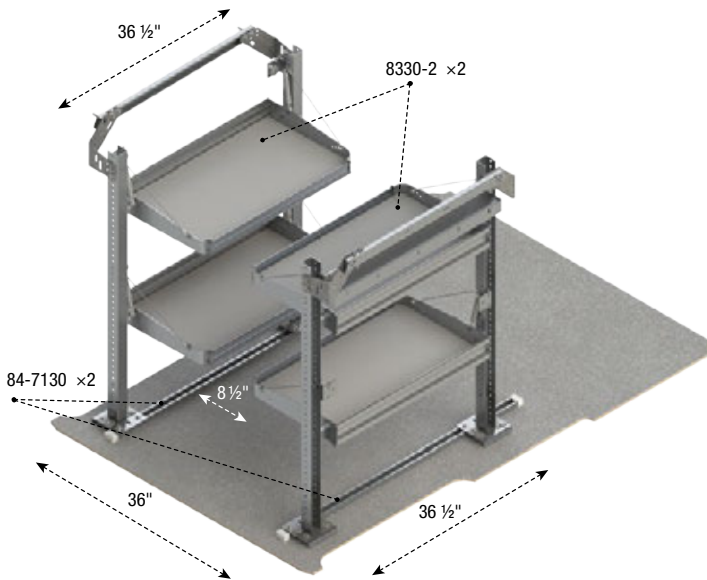

H419

Deluxe Delivery Package

Aluminum

122"	106 lbs	5.4 hrs
Standard	Yes	

Qty	Part #	Description
2	8330-2	Fold-Away Shelving
2	84-7130	Shelving install kit

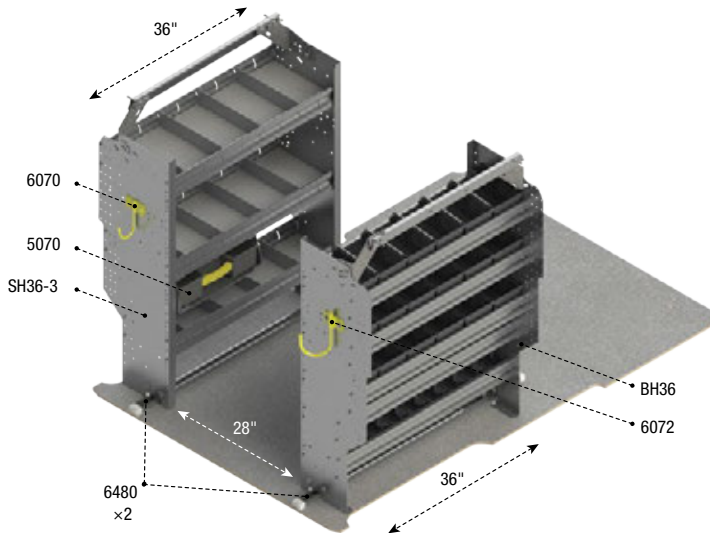

H311

Base Electrical Package

Aluminum

122"	129 lbs	2.7 hrs
Standard	Yes	

Qty	Part #	Description
1	5070	Partskeeper carry case with holder, universal
1	6070	6" Hook, 3" opening, painted
1	6072	8" Swivel Hook, 4" opening, painted
2	6480	Shelving install kit
1	BH36	Contoured Bin Shelving Unit
1	SH36-3	Contoured Shelving Unit with Dividers

PACKAGES

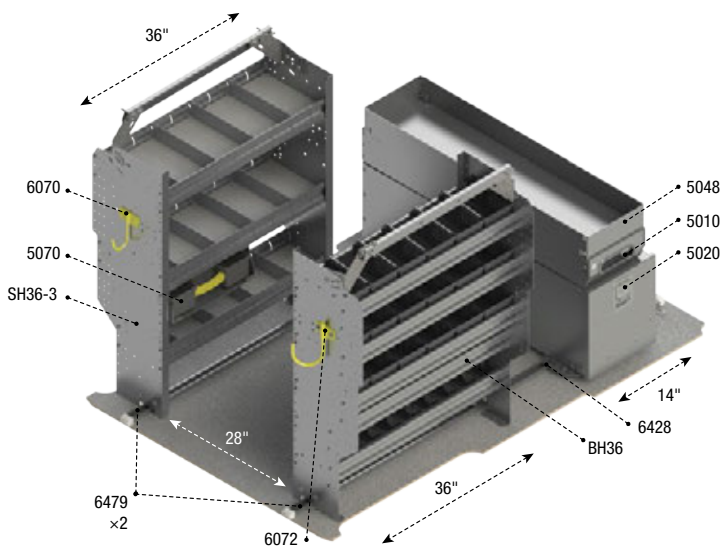

H411

Deluxe Electrical Package

Aluminum

122"	210 lbs	4.4 hrs
Standard	Yes	

Qty	Part #	Description
1	5010	Partslider drawer
1	5020	Tool drawer
1	5048	Top edge, for 5010 Partslider
1	5070	Partskeeper carry case with holder, universal
1	6070	6" Hook, 3" opening, painted
1	6072	8" Swivel Hook, 4" opening, painted
1	6428	5020 Tool drawer install kit
2	6479	Shelving install kit
1	BH36	Contoured Bin Shelving Unit
1	SH36-3	Contoured Shelving Unit with Dividers

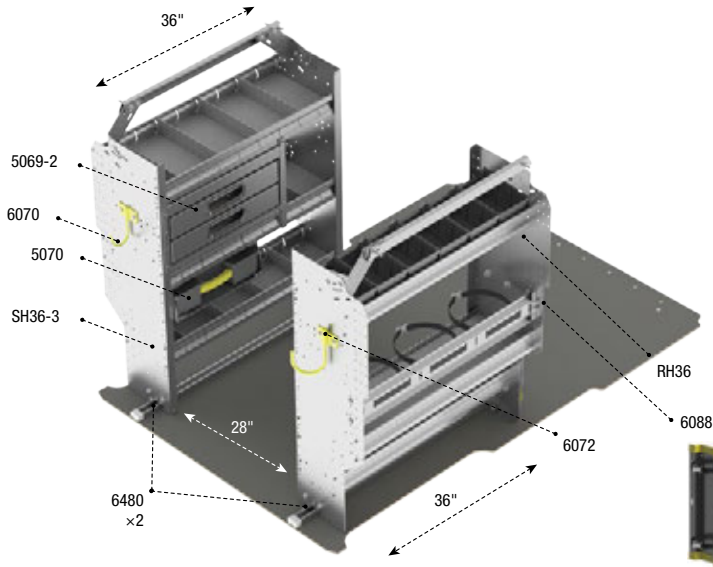

H312

Base HVAC Package

Aluminum

122"	144 lbs	3.4 hrs
Standard	Yes	

Qty	Part #	Description
1	5069-2	2 Drawer cabinet
1	5070	Partskeeper carry case with holder, universal
1	6070	6" Hook, 3" opening, painted
1	6072	8" Swivel Hook, 4" opening, painted
1	6088	Large aluminum bottle holder, with two black nylon straps
2	6480	Shelving install kit
1	RH36	Contoured Refrigerant Bin Unit
1	SH36-3	Contoured Shelving Unit with Dividers

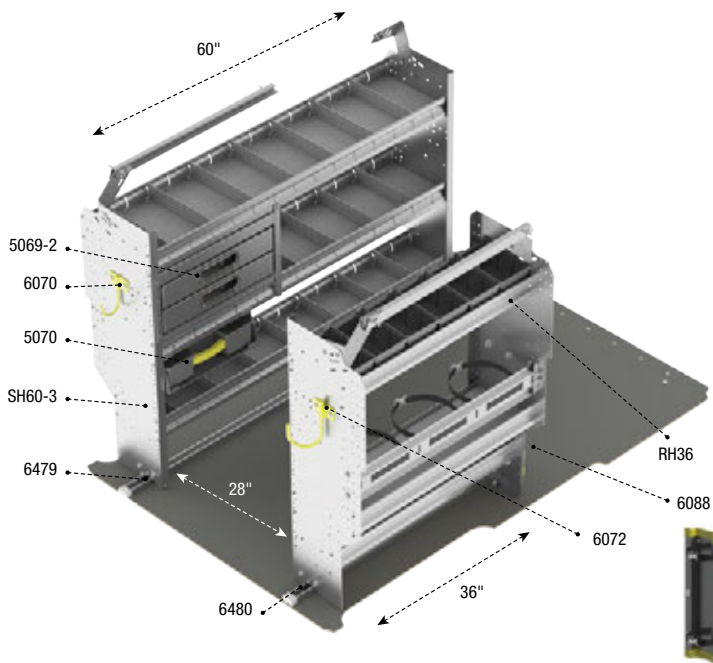

H412

Deluxe HVAC Package

Aluminum

122"	161 lbs	3.4 hrs
Standard	Yes	

Qty	Part #	Description
1	5069-2	2 Drawer cabinet
1	5070	Partskeeper carry case with holder, universal
1	6070	6" Hook, 3" opening, painted
1	6072	8" Swivel Hook, 4" opening, painted
1	6088	Large aluminum bottle holder, with two black nylon straps
1	6479	Shelving install kit
1	6480	Shelving install kit
1	RH36	Contoured Refrigerant Bin Unit
1	SH60-3	Contoured Shelving Unit with Dividers

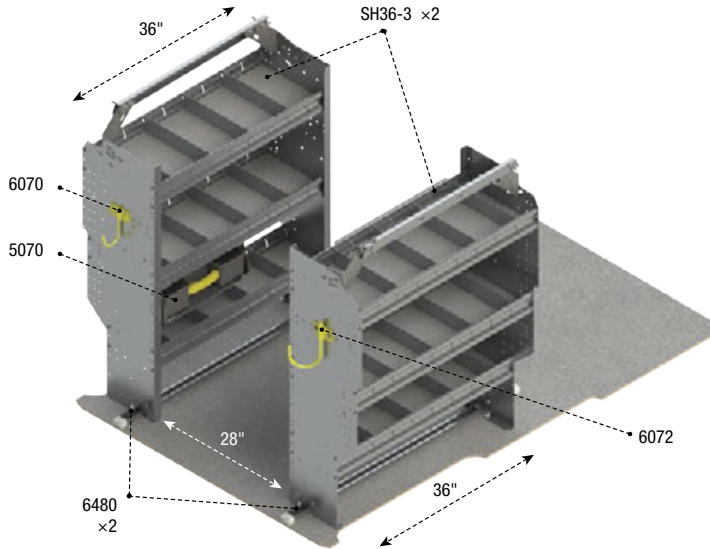

H316

Base Service Package

Aluminum

122"	106 lbs	2.7 hrs
Standard	Yes	

Qty	Part #	Description
1	5070	Partskeeper carry case with holder, universal
1	6070	6" Hook, 3" opening, painted
1	6072	8" Swivel Hook, 4" opening, painted
2	6480	Shelving install kit
2	SH36-3	Contoured Shelving Unit with Dividers

PACKAGES

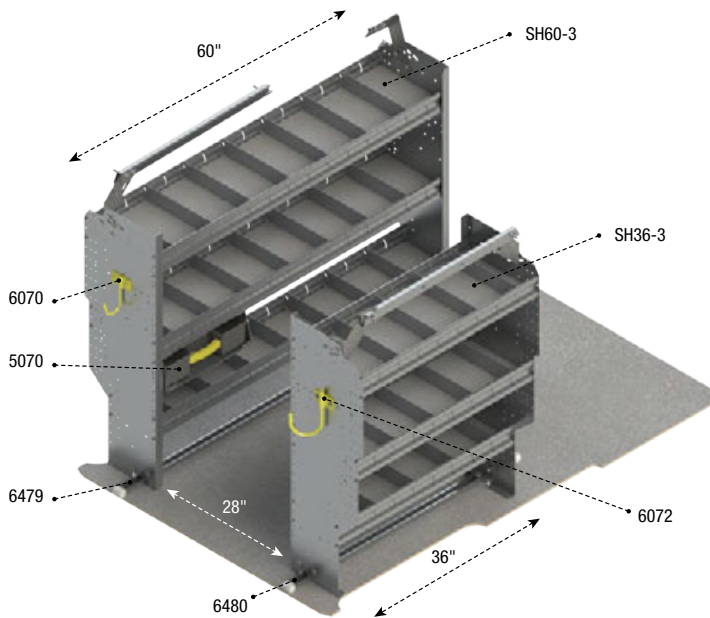

H416

Deluxe Service Package

Aluminum

122"	123 lbs	2.7 hrs
Standard	Yes	

Qty	Part #	Description
1	5070	Partskeeper carry case with holder, universal
1	6070	6" Hook, 3" opening, painted
1	6072	8" Swivel Hook, 4" opening, painted
1	6479	Shelving install kit
1	6480	Shelving install kit
1	SH36-3	Contoured Shelving Unit with Dividers
1	SH60-3	Contoured Shelving Unit with Dividers

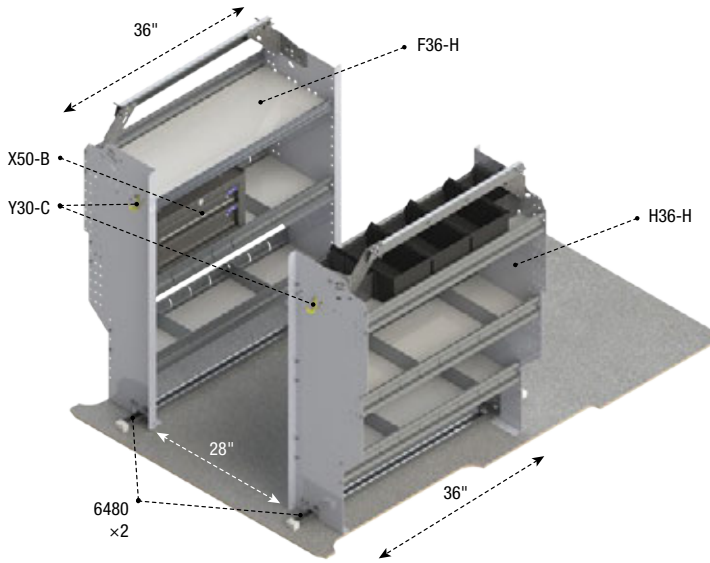

Z16-H3

Base Service Package

Steel

122"	130 lbs	2.7 hrs
Standard	Yes	

Qty	Part #	Description
2	6480	Shelving install kit
1	F36-H	Contoured Shelving Unit with Dividers
1	H36-H	Contoured Bin Shelving Unit
1	X50-B	Compact 2-Drawer Unit
2	Y30-C	Coat Hook, 1" opening, chrome plated

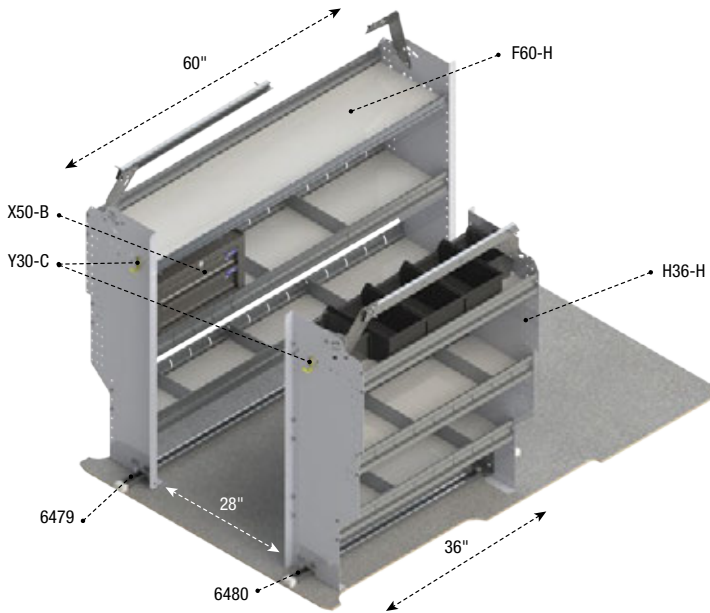

Z16-H4

Deluxe Service Package

Steel

122"	142 lbs	2.7 hrs
Standard	Yes	

Qty	Part #	Description
1	6479	Shelving install kit
1	6480	Shelving install kit
1	F60-H	Contoured Shelving Unit with Dividers
1	H36-H	Contoured Bin Shelving Unit
1	X50-B	Compact 2-Drawer Unit
2	Y30-C	Coat Hook, 1" opening, chrome plated



RANGER DESIGN PACKAGES

Get more out of your work van: Ranger Design packages are designed specifically with your trade in mind. Our aim is to ensure that your most frequently used tools and equipment are well within reach.

Do you see a way we can improve our packages? We appreciate your feedback! Contact our customer service team at **1-800-565-5321**.

Mercedes-Benz Metris Z16-M0 Package





SHELVING

Industry leading strength.
The perfect fit for the toughest jobs.

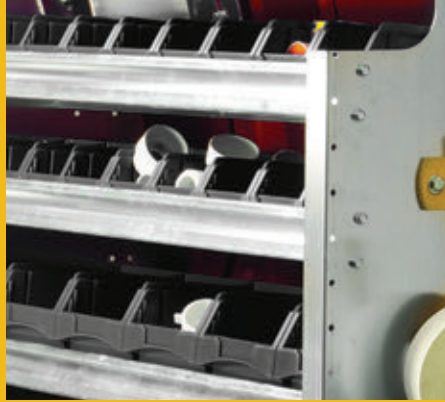

TOUGH

Extrusion builds durability into shelf.



QUIET

Shelf tray, end panel and extrusion are engineered to be vibration free.



ORGANIZED

A well-Planned van outfit increases productivity.

SHELVING

BOOKSHELVES..... P. 176

CONTOURED UNITS

CONTOURED BIN SHELVING UNIT P. 176

CONTOURED REFRIGERANT BIN UNIT P. 181

CONTOURED SHELVING UNIT P. 183

CONTOURED SHELVING UNIT W/ DIVIDERS . . . P. 185

DEEP SQUARE BACK UNITS

DEEP SQ. BACK BIN SHELVING UNIT P. 195

DEEP SQ. BACK SHELVING UNIT..... P. 195

DEEP SQ. BACK SHELVING UNIT W/ DIVIDERS . P. 196

FOLD-AWAY SHELVING..... P. 197

SQUARE BACK UNITS

SQUARE BACK BIN SHELVING UNIT P. 199

SQUARE BACK SHELVING UNIT P. 201

SQUARE BACK SHELVING UNIT W/ DIVIDERS . P. 203

DOORS P. 207

LOCKERS P. 208

WORKBENCHES..... P. 208











Ranger Design shelving is built strong and durable and often outlasts the vehicle. Designed to fit with maximum efficiency, Ranger shelving optimizes the space in a work van's cargo area.



Application Guide

















Type	Material	Box Truck & Trailer	Chevrolet City Express	Chevrolet Express	Ford E-Series	Ford Transit Low Roof	Ford Transit Medium Roof	Ford Transit High Roof	Ford Transit Connect
Bookshelf	Aluminum	71 p. 176		71 p. 176	71 p. 176	71 p. 176	71 p. 176	71 p. 176	
Contoured Bin Shelving Unit	Aluminum		BD p. 178	52 p. 176 96 p. 177	52 p. 176 96 p. 177	BB p. 177	BC p. 178	BC p. 178	BE p. 178
Contoured Bin Shelving Unit	Steel		HW p. 181	HA p. 179	HA p. 179				HE p. 180 HF p. 180
Contoured Refrigerant Bin Unit	Aluminum		RD p. 182	54 p. 181	54 p. 181	RB p. 182	RC p. 182	RC p. 182	
Contoured Shelving Unit	Steel		LW p. 185	LA p. 183	LA p. 183				LE p. 184 LF p. 184
Contoured Shelving Unit with Dividers	Aluminum		SD p. 193	40 p. 185 95 p. 188	40 p. 185 95 p. 188	SB p. 191	SC p. 192	SC p. 192	SE p. 193 SF p. 193
Contoured Shelving Unit with Dividers	Steel		FW p. 190	FA p. 189	FA p. 189				FE p. 189 FF p. 190
Deep Square Back Bin Shelving Unit	Steel	HT p. 195					HT p. 195	HT p. 195	
Deep Square Back Shelving Unit	Steel	LT p. 195					LT p. 195	LT p. 195	
Deep Square Back Shelving Unit with Dividers	Steel	FT p. 196					FT p. 196	FT p. 196	
Fold-Away Shelf Tray with Gas Shocks and Hardware	Aluminum	84 p. 197	84 p. 197	84 p. 197	84 p. 197	84 p. 197	84 p. 197	84 p. 197	84 p. 197
Fold-Away Shelving	Aluminum	84 p. 197	83 p. 197	85 p. 198	85 p. 198	85 p. 198	84 p. 197	84 p. 197	83 p. 197
Mounting Bar Assembly for Fold-Away Shelving	Aluminum	84 p. 198	84 p. 198	84 p. 198	84 p. 198	84 p. 198	84 p. 198	84 p. 198	84 p. 198
Post Assembly for Fold-Away Shelving	Aluminum	84 p. 199	84 p. 199	84 p. 199	84 p. 199	84 p. 199	84 p. 199	84 p. 199	84 p. 199
Square Back Bin Shelving Unit	Aluminum	73 p. 199 78 p. 199 91 p. 200	78 p. 199	78 p. 199	78 p. 199	78 p. 199	78 p. 199	78 p. 199	78 p. 199
Square Back Bin Shelving Unit	Steel	HX p. 201				HR p. 200	HX p. 201	HX p. 201	
Square Back Shelving Unit	Steel	LX p. 202				LR p. 202	LX p. 202	LX p. 202	
Square Back Shelving Unit with Dividers	Aluminum	48 p. 203 90 p. 204							
Square Back Shelving Unit with Dividers	Steel	FX p. 206				FR p. 206	FX p. 206	FX p. 206	

										
GMC Savana	Mercedes-Benz Metris	Mercedes-Benz Sprinter Low Roof	Mercedes-Benz Sprinter High Roof	Nissan NV Low Roof	Nissan NV High Roof	Nissan NV200	Ram C/V	Ram ProMaster	Ram ProMaster High Roof	Ram ProMaster City
71 p. 176		71 p. 176	71 p. 176	71 p. 176	71 p. 176		71 p. 176	71 p. 176	71 p. 176	
52 p. 176 96 p. 177	BL p. 179	79 p. 176	79 p. 176 89 p. 177	BB p. 177	BC p. 178	BD p. 178		BC p. 178	BC p. 178	BH p. 179
HA p. 179	HL p. 180					HW p. 181				HH p. 180
54 p. 181	RL p. 183	57 p. 181	57 p. 181 87 p. 182	RB p. 182	RC p. 182	RD p. 182		RC p. 182	RC p. 182	RH p. 183
LA p. 183	LL					LW p. 185				LH p. 184
40 p. 185 95 p. 188	SL p. 194	41 p. 186	41 p. 186 88 p. 187	SB p. 191	SC p. 192	SD p. 193		SC p. 192	SC p. 192	SH p. 194
FA p. 189	FL p. 190					FW p. 190				FH p. 190
		HT p. 195	HT p. 195		HT p. 195			HT p. 195	HT p. 195	
		LT p. 195	LT p. 195		LT p. 195			LT p. 195	LT p. 195	
		FT p. 196	FT p. 196		FT p. 196			FT p. 196	FT p. 196	
84 p. 197	84 p. 197	84 p. 197	84 p. 197	84 p. 197	84 p. 197	84 p. 197	84 p. 197	84 p. 197	84 p. 197	84 p. 197
85 p. 198	86 p. 198	84 p. 197	84 p. 197	85 p. 198	84 p. 197	83 p. 197		84 p. 197	84 p. 197	83 p. 197
84 p. 198	84 p. 198	84 p. 198	84 p. 198	84 p. 198	84 p. 198	84 p. 198	84 p. 198	84 p. 198	84 p. 198	84 p. 198
84 p. 199	84 p. 199	84 p. 199	84 p. 199	84 p. 199	84 p. 199	84 p. 199	84 p. 199	84 p. 199	84 p. 199	84 p. 199
78 p. 199	78 p. 199	78 p. 199	78 p. 199	78 p. 199	78 p. 199	78 p. 199	51 p. 199 78 p. 199	78 p. 199	78 p. 199	78 p. 199
		HX p. 201	HX p. 201	HR p. 200	HX p. 201		HG p. 200	HX p. 201	HX p. 201	
		LX p. 202	LX p. 202	LR p. 202	LX p. 202		LG p. 201	LX p. 202	LX p. 202	
							43 p. 203 45 p. 203			
		FX p. 206	FX p. 206	FR p. 206	FX p. 206		FG p. 205	FX p. 206	FX p. 206	

SHELVING – BOOKSHELF

Bookshelf













Aluminum

							
Box Truck	Transit High Roof	Transit Medium Roof	Sprinter High Roof	Sprinter Low Roof	NV High Roof	ProMaster High Roof	ProMaster Low Roof
							
7108	14" D x 9" W x 62.5" H	30 lbs	12.5"			0.5 hr	Yes



Bookshelf











Aluminum

							
Express	E-Series	Transit Low Roof	Savana	NV Low Roof			
							
7109	14" D x 9" W x 43" H	18 lbs	12.5"		0.4 hr	No	



Contoured Bin Shelving Unit









Aluminum

							
Express	E-Series	Savana					
							
5236	12.5" D x 36" W x 43" H	49 lbs		18(sm), 18(md)	1 hr	No	
5248	12.5" D x 48" W x 43" H	61 lbs		24(sm), 24(md)	1 hr	No	
5260	12.5" D x 60" W x 43" H	75 lbs		30(sm), 30(md)	1 hr	No	



Contoured Bin Shelving Unit

Aluminum

							
Sprinter High Roof	Sprinter Low Roof						
							
7936	15.5" D x 36" W x 62.5" H	99 lbs		18(sm), 18(md), 8(lrg)	1.4 hrs	No	
7948	15.5" D x 48" W x 62.5" H	123 lbs		24(sm), 24(md), 12(lrg)	1.4 hrs	Yes	
7960	15.5" D x 60" W x 62.5" H	143 lbs		30(sm), 30(md), 14(lrg)	1.4 hrs	No	

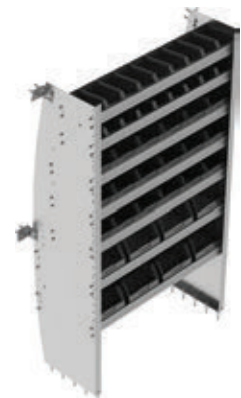

SHELVING – CONTOURED BIN SHELVING UNIT

Contoured Bin Shelving Unit

Aluminum



Sprinter
High Roof



8936-7	15.5" D x 36" W x 72" H	100 lbs			18(sm), 18(md), 8(lrg)	1.4 hrs	No
8948-7	15.5" D x 48" W x 72" H	124 lbs			24(sm), 24(md), 12(lrg)	1.4 hrs	No
8960-7	15.5" D x 60" W x 72" H	144 lbs			30(sm), 30(md), 14(lrg)	1.4 hrs	No



Contoured Bin Shelving Unit

Aluminum



Sprinter
High Roof



8936-8	15.5" D x 36" W x 72" H	112 lbs			18(sm), 18(md), 12(lrg)	1.4 hrs	No
8948-8	15.5" D x 48" W x 72" H	140 lbs			24(sm), 24(md), 18(lrg)	1.4 hrs	No
8960-8	15.5" D x 60" W x 72" H	164 lbs			30(sm), 30(md), 21(lrg)	1.4 hrs	No

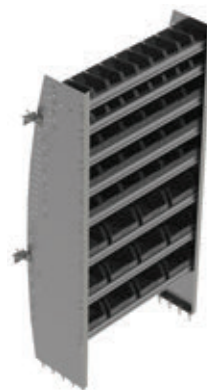

Contoured Bin Shelving Unit

Aluminum



Express

E-Series

Savana



9636	16.5" D x 36" W x 43" H	53 lbs			12(md), 8(lrg)	1 hr	No
9648	16.5" D x 48" W x 43" H	67 lbs			16(md), 12(lrg)	1 hr	Yes
9660	16.5" D x 60" W x 43" H	79 lbs			20(md), 14(lrg)	1 hr	No

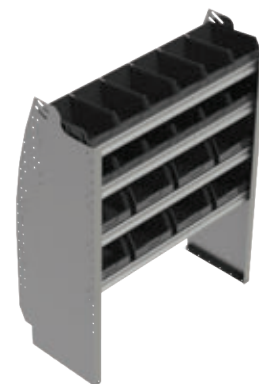

Contoured Bin Shelving Unit

Aluminum



Transit
Low Roof

NV
Low Roof



BB36	15" D x 36" W x 46" H	63 lbs			6 (md), 12 (lrg)	1 hr	No
BB48	15" D x 48" W x 46" H	81 lbs			8 (md), 18 (lrg)	1 hr	Yes
BB60	15" D x 60" W x 46" H	96 lbs			10 (md), 21 (lrg)	1 hr	No



SHELVING – CONTOURED BIN SHELVING UNIT

Contoured Bin Shelving Unit

Aluminum



Transit High Roof

Transit Medium Roof

NV High Roof

ProMaster High Roof

ProMaster

Does not fit over wheel well in ProMaster.



BC36	15.5" D x 36" W x 62.5" H	82 lbs	6 Shelves (9", 9", 9", 13", 13", 13")	18 (md), 12 (lrg)	1.4 hrs	No
BC48	15.5" D x 48" W x 62.5" H	104 lbs	6 Shelves (9", 9", 9", 13", 13", 13")	24 (md), 18 (lrg)	1.4 hrs	Yes
BC60	15.5" D x 60" W x 62.5" H	123 lbs	6 Shelves (9", 9", 9", 13", 13", 13")	30 (md), 21 (lrg)	1.4 hrs	No

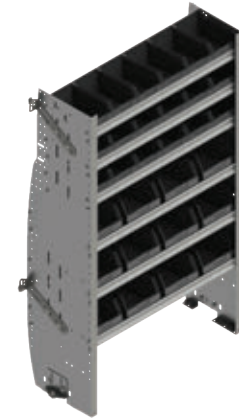

Contoured Bin Shelving Unit

Aluminum



Transit High Roof

Transit Medium Roof

NV High Roof

ProMaster High Roof

ProMaster



BC36-5	15.5" D x 36" W x 62.5" H	71 lbs	5 Shelves (9.5", 9.5", 9.5", 13", 13")	18 (md), 8 (lrg)	1.4 hrs	No
BC48-5	15.5" D x 48" W x 62.5" H	89 lbs	5 Shelves (9.5", 9.5", 9.5", 13", 13")	24 (md), 12 (lrg)	1.4 hrs	No
BC60-5	15.5" D x 60" W x 62.5" H	104 lbs	5 Shelves (9.5", 9.5", 9.5", 13", 13")	30 (md), 14 (lrg)	1.4 hrs	No



Contoured Bin Shelving Unit

Aluminum



City Express

NV200



BD36	14" D x 36" W x 40" H	49 lbs		18(sm), 18(md)	1 hr	Yes
-------------	-----------------------	--------	--	----------------	------	-----



Contoured Bin Shelving Unit

Aluminum



Transit Connect



BE36	12.5" D x 36" W x 44" H	49 lbs		27 (sm), 12 (md)	1 hr	Yes
-------------	-------------------------	--------	--	------------------	------	-----

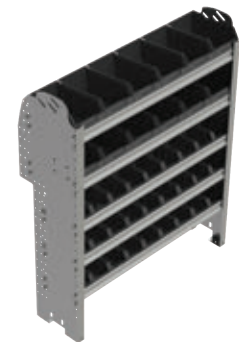

SHELVING – CONTOURED BIN SHELVING UNIT

Contoured Bin Shelving Unit

Aluminum



ProMaster
City



	Dimensions	Weight	Shelf Opening	Dividers	Bins	Estimated Install Time	Quickship
BH36	15" D x 36" W x 45" H	64 lbs			18 (sm), 18 (md)	1 hr	Yes
BH48	15" D x 48" W x 45" H	81 lbs			24 (sm), 24 (md)	1 hr	No
BH60	15" D x 60" W x 45" H	97 lbs			30 (sm), 30 (md)	1 hr	No



Contoured Bin Shelving Unit

Aluminum



Metris



	Dimensions	Weight	Shelf Opening	Dividers	Bins	Estimated Install Time	Quickship
BL36	14" D x 36" W x 46" H	62 lbs			24 (md)	1 hr	Yes
BL48	14" D x 48" W x 46" H	76 lbs			32 (md)	1 hr	No
BL60	14" D x 60" W x 46" H	91 lbs			40 (md)	1 hr	No

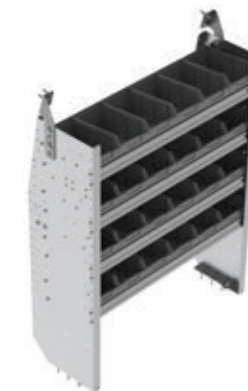

Contoured Bin Shelving Unit

Steel



Express

E-Series

Savana



	Dimensions	Weight	Shelf Opening	Dividers	Bins	Estimated Install Time	Quickship
H38-A	15" D x 38" W x 46" H	63 lbs	3 Shelves (9", 12", 13")	6	6	1 hr	No
H42-A	15" D x 42" W x 46" H	68 lbs	3 Shelves (9", 12", 13")	6	7	1 hr	No
H56-A	15" D x 56" W x 46" H	81 lbs	3 Shelves (9", 12", 13")	8	9	1 hr	No
H70-A	15" D x 70" W x 46" H	95 lbs	3 Shelves (9", 12", 13")	8	11	1 hr	No

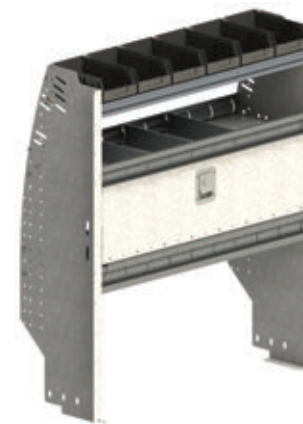

Contoured Bin Shelving Unit

Steel



Express

E-Series

Savana



	Dimensions	Weight	Shelf Opening	Dividers	Bins	Estimated Install Time	Quickship
H87-A	15" D x 87" W x 46" H	116 lbs	3 Shelves (9", 12", 13")	12	14	1 hr	No



SHELVING – CONTOURED BIN SHELVING UNIT

Contoured Bin Shelving Unit

Steel



Transit
Connect



H36-E 12.5" D x 36" W x 44" H 60 lbs

1 hr Yes

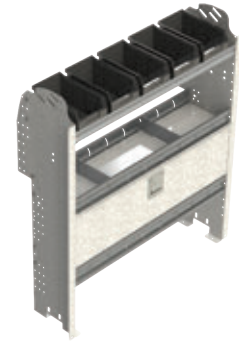

Contoured Bin Shelving Unit

Steel



Transit
Connect



H36-F 17.5" D x 36" W x 44" H 63 lbs

1 hr Yes

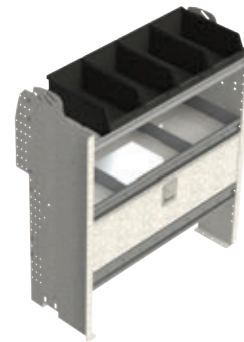

Contoured Bin Shelving Unit

Steel



ProMaster
City



H36-H 15" D x 36" W x 45" H 54 lbs

1 hr Yes



Contoured Bin Shelving Unit

Steel



Metris



H36-L 14" D x 36" W x 46" H 58 lbs

3 Shelves (11", 13", 13")

4

6 (md)

1 hr

No

H48-L 14" D x 48" W x 46" H 68 lbs

3 Shelves (11", 13", 13")

6

8 (md)

1 hr

No

H60-L 14" D x 60" W x 46" H 79 lbs

3 Shelves (11", 13", 13")

8

10 (md)

1 hr

No

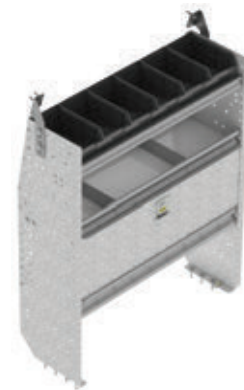

SHELVING – CONTOURED BIN SHELVING UNIT

Contoured Bin Shelving Unit

Steel



Metris



H72-L	14" D x 72" W x 46" H	91 lbs	3 Shelves (11", 13", 13")	12	12 (md)	1 hr	No
--------------	-----------------------	--------	---------------------------	----	---------	------	----



Contoured Bin Shelving Unit

Steel



City Express



NV200



H32-W	14" D x 32" W x 46" H	58 lbs	3 Shelves (9", 12", 13")	6	5 (md)	1 hr	Yes
--------------	-----------------------	--------	--------------------------	---	--------	------	-----

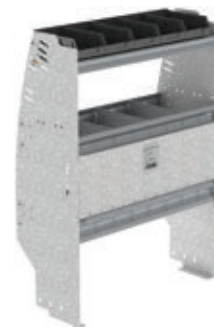

Contoured Refrigerant Bin Unit

Aluminum



Express



E-Series



Savana



5448	12.5" D x 48" W x 43" H	42 lbs		4	24(sm)	1 hr	No
5460	12.5" D x 60" W x 43" H	50 lbs		5	30(sm)	1 hr	No



Contoured Refrigerant Bin Unit

Aluminum



Sprinter High Roof



Sprinter Low Roof



5748	16" D x 48" W x 62.5" H	106 lbs		4	24(sm), 24(md)	1.2 hrs	No
5760	16" D x 60" W x 62.5" H	120 lbs		5	30(sm), 30(md)	1.2 hrs	No



SHELVINGS



SHELVING – CONTOURED REFRIGERANT BIN UNIT

Contoured Refrigerant Bin Unit

Aluminum



Sprinter
High Roof



8748	15.5" D x 48" W x 72" H	107 lbs		4	24(sm), 24(md)	1.4 hrs	No
8760	15.5" D x 60" W x 72" H	121 lbs		5	30(sm), 30(md)	1.4 hrs	No



Contoured Refrigerant Bin Unit

Aluminum



Transit
Low Roof



NV
Low Roof



RB48	15" D x 48" W x 46" H	38 lbs	2 Shelves (9", 13.5")	4	8(md)	1 hr	Yes
RB60	15" D x 60" W x 46" H	45 lbs	2 Shelves (9", 13.5")	5	10(md)	1 hr	No



Contoured Refrigerant Bin Unit

Aluminum



Transit
High Roof



Transit
Medium
Roof



NV
High Roof



ProMaster
High Roof



ProMaster



RC48	15.5" D x 48" W x 62.5" H	106 lbs	4 Shelves (9", 9", 9", 12.5")	4	24(md)	1.2 hrs	Yes
RC60	15.5" D x 60" W x 62.5" H	120 lbs	4 Shelves (9", 9", 9", 12.5")	5	30(md)	1.2 hrs	Yes



Contoured Refrigerant Bin Unit

Aluminum



City Express



NV200



RD36	13.75" D x 36" W x 40" H	28 lbs		3	18(sm)	1.3 hrs	No
-------------	--------------------------	--------	--	---	--------	---------	----



SHELVING – CONTOURED REFRIGERANT BIN UNIT

Contoured Refrigerant Bin Unit

Aluminum



ProMaster
City



	Dimensions	Weight	Shelf Opening	Dividers	Bins	Estimated Install Time	Quickship
RH36	15" D x 36" W x 45" H	43 lbs			9(sm), 6(lrg)	1 hr	Yes
RH48	15" D x 48" W x 45" H	52 lbs			12(sm), 8(lrg)	1 hr	No
RH60	15" D x 60" W x 45" H	62 lbs			15(sm), 10(lrg)	1 hr	No



Contoured Refrigerant Bin Unit

Aluminum



Metris



	Dimensions	Weight	Shelf Opening	Dividers	Bins	Estimated Install Time	Quickship
RL36	14" D x 36" W x 46" H	38 lbs			6 (md)	1 hr	Yes



Contoured Shelving Unit

Steel



Express



E-Series



Savana



	Dimensions	Weight	Shelf Opening	Dividers	Bins	Estimated Install Time	Quickship
L38-A	14" D x 38" W x 46" H	61 lbs		4 Shelves (9", 12", 13", 13")		1 hr	No
L42-A	14" D x 42" W x 46" H	65 lbs		4 Shelves (9", 12", 13", 13")		1 hr	No
L56-A	14" D x 56" W x 46" H	78 lbs		4 Shelves (9", 12", 13", 13")		1 hr	No
L70-A	14" D x 70" W x 46" H	91 lbs		4 Shelves (9", 12", 13", 13")		1 hr	No



Contoured Shelving Unit

Steel



Express



E-Series



Savana



	Dimensions	Weight	Shelf Opening	Dividers	Bins	Estimated Install Time	Quickship
L87-A	14" D x 87" W x 46" H	113 lbs		4 Shelves (9", 12", 13", 13")		1 hr	No



SHELVING – CONTOURED SHELVING UNIT

Contoured Shelving Unit

Steel



Transit
Connect



L36-E	15" D × 36" W × 44" H	60 lbs				1 hr	Yes
--------------	-----------------------	--------	--	--	--	------	-----



Contoured Shelving Unit

Steel



Transit
Connect



L36-F	15" D × 36" W × 44" H	62 lbs				1 hr	Yes
--------------	-----------------------	--------	--	--	--	------	-----

L60-F	15" D × 60" W × 44" H	83 lbs				1 hr	Yes
--------------	-----------------------	--------	--	--	--	------	-----



Contoured Shelving Unit

Steel



ProMaster
City



L36-H	15" D × 36" W × 45" H	48 lbs				1 hr	No
--------------	-----------------------	--------	--	--	--	------	----

L60-H	15" D × 60" W × 45" H	64 lbs				1 hr	No
--------------	-----------------------	--------	--	--	--	------	----



Contoured Shelving Unit

Steel



Metris



L36-L	14" D × 36" W × 46" H	51 lbs	4 Shelves (11", 12", 13", 13")			1 hr	No
--------------	-----------------------	--------	--------------------------------	--	--	------	----

L48-L	14" D × 48" W × 46" H	59 lbs	4 Shelves (11", 12", 13", 13")			1 hr	No
--------------	-----------------------	--------	--------------------------------	--	--	------	----

L60-L	14" D × 60" W × 46" H	66 lbs	4 Shelves (11", 12", 13", 13")			1 hr	No
--------------	-----------------------	--------	--------------------------------	--	--	------	----

L72-L	14" D × 72" W × 46" H	76 lbs	4 Shelves (11", 12", 13", 13")			1 hr	No
--------------	-----------------------	--------	--------------------------------	--	--	------	----

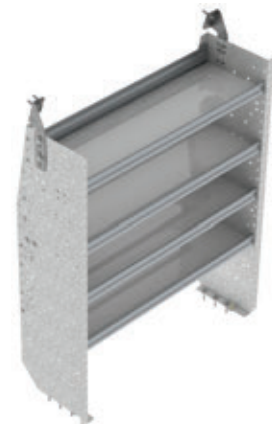

SHELVING – CONTOURED SHELVING UNIT

Contoured Shelving Unit

Steel



City Express



NV200



L32-W	14" D x 32" W x 46" H	55 lbs	4 Shelves (9", 12", 13", 13")			1 hr	Yes
L56-W	14" D x 56" W x 46" H	78 lbs	4 Shelves (9", 12", 13", 13")			1 hr	Yes



Contoured Shelving Unit with Dividers

Aluminum



Express



E-Series



Savana



4036-3	14" D x 36" W x 43" H	36 lbs	3 Shelves (8", 11", 12")	18	7723	0.8 hr	No
4048-3	14" D x 48" W x 43" H	44 lbs	3 Shelves (8", 11", 12")	18	7720	0.8 hr	No
4060-3	14" D x 60" W x 43" H	52 lbs	3 Shelves (8", 11", 12")	24	7722	0.8 hr	No



Contoured Shelving Unit with Dividers

Aluminum



Express



E-Series



Savana



4036-4	14" D x 36" W x 43" H	45 lbs	4 Shelves (8", 10", 11", 12")	24	N/A	0.8 hr	No
4048-4	14" D x 48" W x 43" H	54 lbs	4 Shelves (8", 10", 11", 12")	24	N/A	0.8 hr	No
4060-4	14" D x 60" W x 43" H	64 lbs	4 Shelves (8", 10", 11", 12")	32	N/A	0.8 hr	No



Contoured Shelving Unit with Dividers

Aluminum



Express



E-Series



Savana



4072-3	14" D x 72" W x 43" H	60 lbs	3 Shelves (8", 11", 12")	30	7723	1 hr	No
4084-3	14" D x 84" W x 43" H	68 lbs	3 Shelves (8", 11", 12")	30	N/A	1 hr	No
4096-3	14" D x 96" W x 43" H	78 lbs	3 Shelves (8", 11", 12")	36	7720	1 hr	Yes



SHELVING – CONTOURED SHELVING UNIT WITH DIVIDERS

Contoured Shelving Unit with Dividers

Aluminum



Express

E-Series

Savana



4072-4	14" D x 72" W x 43" H	74 lbs	4 Shelves (8", 10", 11", 12")	40	N/A	1 hr	No
4084-4	14" D x 84" W x 43" H	85 lbs	4 Shelves (8", 10", 11", 12")	40	N/A	1 hr	No
4096-4	14" D x 96" W x 43" H	97 lbs	4 Shelves (8", 10", 11", 12")	48	N/A	1 hr	No



Contoured Shelving Unit with Dividers

Aluminum



Sprinter
High Roof

Sprinter
Low Roof



4136-4	16" D x 36" W x 62.5" H	46 lbs	4 Shelves (10", 11", 13", 13")	24	7733	1.2 hrs	No
4148-4	16" D x 48" W x 62.5" H	56 lbs	4 Shelves (10", 11", 13", 13")	24	7730	1.2 hrs	No
4160-4	16" D x 60" W x 62.5" H	66 lbs	4 Shelves (10", 11", 13", 13")	32	7732	1.2 hrs	No

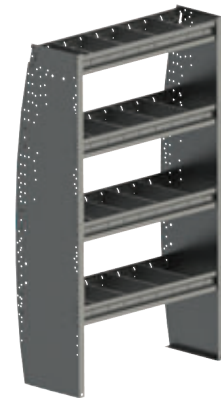

Contoured Shelving Unit with Dividers

Aluminum



Sprinter
High Roof

Sprinter
Low Roof



4136-5	16" D x 36" W x 62.5" H	53 lbs	5 Shelves (10", 11", 13", 13", 13")	30	7728	1.2 hrs	No
4148-5	16" D x 48" W x 62.5" H	65 lbs	5 Shelves (10", 11", 13", 13", 13")	30	7725	1.2 hrs	No
4160-5	16" D x 60" W x 62.5" H	78 lbs	5 Shelves (10", 11", 13", 13", 13")	40	7727	1.2 hrs	No



Contoured Shelving Unit with Dividers

Aluminum



Sprinter
High Roof

Sprinter
Low Roof



4172-4	16" D x 72" W x 62.5" H	76 lbs	4 Shelves (10", 11", 13", 13")	40	7733	1.4 hrs	No
4184-4	16" D x 84" W x 62.5" H	88 lbs	4 Shelves (10", 11", 13", 13")	40	N/A	1.4 hrs	Yes
4196-4	16" D x 96" W x 62.5" H	98 lbs	4 Shelves (10", 11", 13", 13")	48	7730	1.4 hrs	No



SHELVING – CONTOURED SHELVING UNIT WITH DIVIDERS

Contoured Shelving Unit with Dividers

Aluminum



Sprinter
High Roof

Sprinter
Low Roof



4172-5	16" D x 72" W x 62.5" H	90 lbs	5 Shelves (10", 11", 13", 13", 13")	50	7728	1.4 hrs	No
4184-5	16" D x 84" W x 62.5" H	102 lbs	5 Shelves (10", 11", 13", 13", 13")	50	N/A	1.4 hrs	No
4196-5	16" D x 96" W x 62.5" H	118 lbs	5 Shelves (10", 11", 13", 13", 13")	60	7725	1.4 hrs	No



Contoured Shelving Unit with Dividers

Aluminum



Sprinter
High Roof



8848-5	15.5" D x 48" W x 72" H	66 lbs	5 Shelves (8", 11", 12", 13", 13")	30	7725	1.3 hrs	No
8860-5	15.5" D x 60" W x 72" H	79 lbs	5 Shelves (8", 11", 12", 13", 13")	40	7727 or 7732	1.3 hrs	No



Contoured Shelving Unit with Dividers

Aluminum



Sprinter
High Roof



8848-6	15.5" D x 48" W x 72" H	75 lbs	6 Shelves (8", 11", 12", 13", 13", 13")	36	7720	1.3 hrs	No
8860-6	15.5" D x 60" W x 72" H	91 lbs	6 Shelves (8", 11", 12", 13", 13", 13")	48	7722	1.3 hrs	No



Contoured Shelving Unit with Dividers

Aluminum



Sprinter
High Roof



8872-5	15.5" D x 72" W x 72" H	91 lbs	5 Shelves (8", 11", 12", 13", 13")	40	7728	1.3 hrs	No
8884-5	15.5" D x 84" W x 72" H	103 lbs	5 Shelves (8", 11", 12", 13", 13")	50	N/A	1.3 hrs	No
8896-5	15.5" D x 96" W x 72" H	119 lbs	5 Shelves (8", 11", 12", 13", 13")	60	7725	1.3 hrs	No



SHELVING – CONTOURED SHELVING UNIT WITH DIVIDERS

Contoured Shelving Unit with Dividers

Aluminum



Sprinter
High Roof



8872-6	15.5" D x 72" W x 72" H	105 lbs	6 Shelves (8", 11", 12", 13", 13", 13")	48	7723	1.3 hrs	No
8884-6	15.5" D x 84" W x 72" H	117 lbs	6 Shelves (8", 11", 12", 13", 13", 13")	60	N/A	1.3 hrs	No
8896-6	15.5" D x 96" W x 72" H	139 lbs	6 Shelves (8", 11", 12", 13", 13", 13")	72	7720	1.3 hrs	No



Contoured Shelving Unit with Dividers

Aluminum



Express



E-Series



Savana



9536-3	16.5" D x 36" W x 43" H	44 lbs	3 Shelves (11", 14", 15")	12	7728	1 hr	No
9548-3	16.5" D x 48" W x 43" H	53 lbs	3 Shelves (11", 14", 15")	18	7725	1 hr	No
9560-3	16.5" D x 60" W x 43" H	63 lbs	3 Shelves (11", 14", 15")	24	7727	1 hr	No

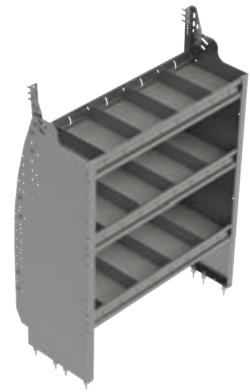

Contoured Shelving Unit with Dividers

Aluminum



Express



E-Series



Savana



9536-4	16.5" D x 36" W x 43" H	53 lbs	4 Shelves (11", 13", 14", 15")	16	N/A	1 hr	No
9548-4	16.5" D x 48" W x 43" H	66 lbs	4 Shelves (11", 13", 14", 15")	24	7720	1 hr	No
9560-4	16.5" D x 60" W x 43" H	79 lbs	4 Shelves (11", 13", 14", 15")	32	7722	1 hr	No

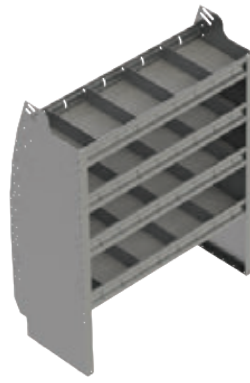

Contoured Shelving Unit with Dividers

Aluminum



Express



E-Series



Savana



9572-3	16.5" D x 72" W x 43" H	76 lbs	3 Shelves (11", 14", 15")	24	7728	1 hr	No
9584-3	16.5" D x 84" W x 43" H	86 lbs	3 Shelves (11", 14", 15")	30	N/A	1 hr	No
9596-3	16.5" D x 96" W x 43" H	95 lbs	3 Shelves (11", 14", 15")	36	7725	1 hr	No

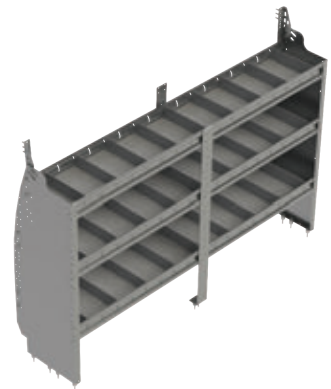

SHELVING – CONTOURED SHELVING UNIT WITH DIVIDERS

Contoured Shelving Unit with Dividers

Aluminum



Express

E-Series

Savana



9572-4	16.5" D x 72" W x 43" H	94 lbs	4 Shelves (11", 13", 14", 15")	32	N/A	1 hr	No
9584-4	16.5" D x 84" W x 43" H	108 lbs	4 Shelves (11", 13", 14", 15")	40	N/A	1 hr	No
9596-4	16.5" D x 96" W x 43" H	120 lbs	4 Shelves (11", 13", 14", 15")	48	7720 x2	1 hr	No

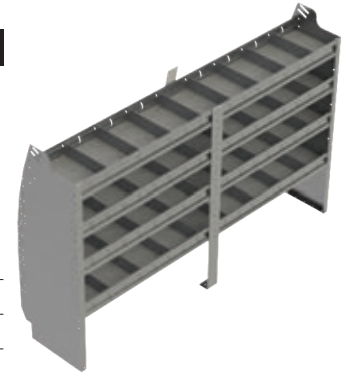

Contoured Shelving Unit with Dividers

Steel



Express

E-Series

Savana



F38-A	15" D x 38" W x 46" H	53 lbs	3 Shelves (9", 12", 13")	6	Y12-D	1 hr	No
F42-A	15" D x 42" W x 46" H	56 lbs	3 Shelves (9", 12", 13")	6	Y12-F	1 hr	Yes
F56-A	15" D x 56" W x 46" H	66 lbs	3 Shelves (9", 12", 13")	8	Y12-J	1 hr	No
F70-A	15" D x 70" W x 46" H	77 lbs	3 Shelves (9", 12", 13")	8	Y12-C	1 hr	No



Contoured Shelving Unit with Dividers

Steel



Express

E-Series

Savana



F87-A	15" D x 87" W x 46" H	95 lbs	3 Shelves (9", 12", 13")	12	Y12-F	1 hr	Yes
--------------	-----------------------	--------	--------------------------	----	-------	------	-----



Contoured Shelving Unit with Dividers

Steel



Transit
Connect



F36-E	12.5" D x 36" W x 44" H	52 lbs	3 Shelves (10", 8", 8")	4	Y11-E	1 hr	Yes
--------------	-------------------------	--------	-------------------------	---	-------	------	-----

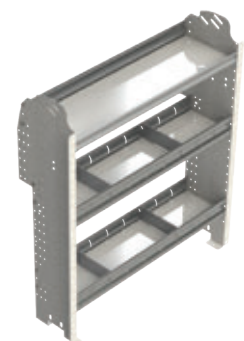

SHELVING – CONTOURED SHELVING UNIT WITH DIVIDERS

Contoured Shelving Unit with Dividers

Steel



Transit
Connect



F36-F	17.5" D × 36" W × 44" H	55 lbs	3 Shelves (13", 13", 15")	4	Y11-E	1 hr	Yes
F60-F	17.5" D × 60" W × 44" H	74 lbs	3 Shelves (13", 13", 15")	8	Y12-E	1 hr	Yes

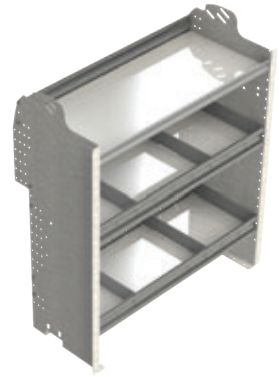

Contoured Shelving Unit with Dividers

Steel



ProMaster
City



F36-H	15" D × 36" W × 45" H	41 lbs	3 Shelves (8", 12", 13")	4	Y11-E	1 hr	Yes
F60-H	15" D × 60" W × 45" H	53 lbs	3 Shelves (8", 12", 13")	8		1 hr	Yes



Contoured Shelving Unit with Dividers

Steel



Metris



F36-L	14" D × 36" W × 46" H	46 lbs	3 Shelves (11", 13", 13")	4	Y10-D	1 hr	Yes
F48-L	14" D × 48" W × 46" H	52 lbs	3 Shelves (11", 13", 13")	6	Y10-H	1 hr	No
F60-L	14" D × 60" W × 46" H	59 lbs	3 Shelves (11", 13", 13")	8	Y10-L	1 hr	No
F72-L	14" D × 72" W × 46" H	67 lbs	3 Shelves (11", 13", 13")	10	Y10-D	1 hr	Yes



Contoured Shelving Unit with Dividers

Steel



City Express



NV200



F32-W	14" D × 32" W × 46" H	48 lbs	3 Shelves (9", 12", 13")	6	Y11-M	1 hr	Yes
F56-W	14" D × 56" W × 46" H	66 lbs	3 Shelves (9", 12", 13")	8	Y11-J	1 hr	Yes



SHELVING – CONTOURED SHELVING UNIT WITH DIVIDERS

Contoured Shelving Unit with Dividers

Aluminum



Transit
Low Roof

NV
Low Roof



Part Number	Dimensions (D x W x H)	Weight	Shelf Opening	Dividers	Bins	Estimated Install Time	Quickship
SB36-3	15.5" D x 36" W x 46" H	39 lbs	3 Shelves (13", 13", 13")	12	7728	0.8 hr	No
SB48-3	15.5" D x 48" W x 46" H	48 lbs	3 Shelves (13", 13", 13")	18	7725	0.8 hr	Yes
SB60-3	15.5" D x 60" W x 46" H	58 lbs	3 Shelves (13", 13", 13")	21	7727	0.8 hr	Yes



Contoured Shelving Unit with Dividers

Aluminum



Transit
Low Roof

NV
Low Roof



Part Number	Dimensions (D x W x H)	Weight	Shelf Opening	Dividers	Bins	Estimated Install Time	Quickship
SB36-4	15.5" D x 36" W x 46" H	49 lbs	4 Shelves (13", 13", 13", 13")	16	7723	0.8 hr	No
SB48-4	15.5" D x 48" W x 46" H	62 lbs	4 Shelves (13", 13", 13", 13")	24	7720	0.8 hr	No
SB60-4	15.5" D x 60" W x 46" H	75 lbs	4 Shelves (13", 13", 13", 13")	28	7722	0.8 hr	No



Contoured Shelving Unit with Dividers

Aluminum



Transit
Low Roof

NV
Low Roof



Part Number	Dimensions (D x W x H)	Weight	Shelf Opening	Dividers	Bins	Estimated Install Time	Quickship
SB72-3	15.5" D x 72" W x 46" H	68 lbs	3 Shelves (13", 13", 13")	24	7728	1 hr	Yes
SB84-3	15.5" D x 84" W x 46" H	78 lbs	3 Shelves (13", 13", 13")	30	N/A	1 hr	No
SB96-3	15.5" D x 96" W x 46" H	87 lbs	3 Shelves (13", 13", 13")	36	7725	1 hr	Yes



Contoured Shelving Unit with Dividers

Aluminum



Transit
Low Roof

NV
Low Roof



Part Number	Dimensions (D x W x H)	Weight	Shelf Opening	Dividers	Bins	Estimated Install Time	Quickship
SB72-4	15.5" D x 72" W x 46" H	88 lbs	4 Shelves (13", 13", 13", 13")	32	7723	1 hr	No
SB84-4	15.5" D x 84" W x 46" H	101 lbs	4 Shelves (13", 13", 13", 13")	40	N/A	1 hr	No
SB96-4	15.5" D x 96" W x 46" H	114 lbs	4 Shelves (13", 13", 13", 13")	48	7720	1 hr	No

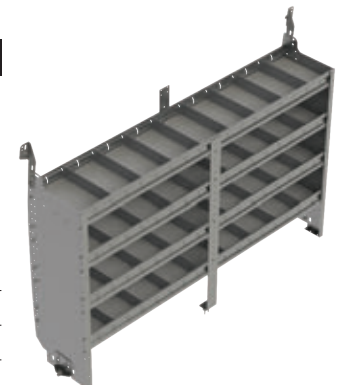

SHELVING – CONTOURED SHELVING UNIT WITH DIVIDERS

Contoured Shelving Unit with Dividers

Aluminum



Transit High Roof Transit Medium Roof NV High Roof ProMaster High Roof ProMaster



SC36-4	15.5" D x 36" W x 62.5" H	46 lbs	4 Shelves (11", 12", 13", 13")	16	7733	1.2 hrs	Yes
SC48-4	15.5" D x 48" W x 62.5" H	56 lbs	4 Shelves (11", 12", 13", 13")	24	7730	1.2 hrs	Yes
SC60-4	15.5" D x 60" W x 62.5" H	66 lbs	4 Shelves (11", 12", 13", 13")	28	7732	1.2 hrs	Yes



Contoured Shelving Unit with Dividers

Aluminum



Transit High Roof Transit Medium Roof NV High Roof ProMaster High Roof ProMaster



SC36-5	15.5" D x 36" W x 62.5" H	53 lbs	5 Shelves (11", 11", 13", 13", 13")	20	7723	1.2 hrs	No
SC48-5	15.5" D x 48" W x 62.5" H	65 lbs	5 Shelves (11", 11", 13", 13", 13")	30	7720	1.2 hrs	No
SC60-5	15.5" D x 60" W x 62.5" H	78 lbs	5 Shelves (11", 11", 13", 13", 13")	35	7722	1.2 hrs	No

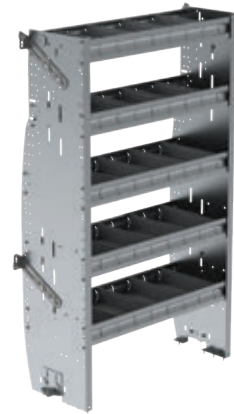

Contoured Shelving Unit with Dividers

Aluminum



Transit High Roof Transit Medium Roof NV High Roof ProMaster High Roof ProMaster



SC72-4	15.5" D x 72" W x 62.5" H	76 lbs	4 Shelves (11", 12", 13", 13")	32	7733	1.4 hrs	Yes
SC84-4	15.5" D x 84" W x 62.5" H	88 lbs	4 Shelves (11", 12", 13", 13")	40	N/A	1.4 hrs	No
SC96-4	15.5" D x 96" W x 62.5" H	98 lbs	4 Shelves (11", 12", 13", 13")	48	7730	1.4 hrs	Yes



SHELVING – CONTOURED SHELVING UNIT WITH DIVIDERS

Contoured Shelving Unit with Dividers

Aluminum



Transit High Roof Transit Medium Roof NV High Roof ProMaster High Roof ProMaster



SC72-5	15.5" D x 72" W x 62.5" H	90 lbs	5 Shelves (11", 11", 13", 13", 13")	40	7723	1.4 hrs	Yes
SC84-5	15.5" D x 84" W x 62.5" H	102 lbs	5 Shelves (11", 11", 13", 13", 13")	50	N/A	1.4 hrs	No
SC96-5	15.5" D x 96" W x 62.5" H	118 lbs	5 Shelves (11", 11", 13", 13", 13")	60	7720	1.4 hrs	No



Contoured Shelving Unit with Dividers

Aluminum



City Express NV200



SD36-3	14" D x 36" W x 40" H	36 lbs	3 Shelves (10", 11", 12")	12	7723	0.8 hr	Yes
SD60-3	14" D x 60" W x 40" H	52 lbs	3 Shelves (10", 11", 12")	24	7727	0.8 hr	Yes



Contoured Shelving Unit with Dividers

Aluminum



Transit Connect



SE36-3	12.5" D x 36" W x 44" H	36 lbs	3 Shelves (8", 11", 10")	12	7728	1 hr	Yes
---------------	-------------------------	--------	--------------------------	----	------	------	-----



Contoured Shelving Unit with Dividers

Aluminum



Transit Connect



SF36-3	17.5" D x 36" W x 44" H	36 lbs	3 Shelves (13", 16", 15")	12	7733	1 hr	Yes
SF60-3	17.5" D x 60" W x 44" H	52 lbs	3 Shelves (13", 16", 15")	21	7732	1 hr	Yes



SHELVING – CONTOURED SHELVING UNIT WITH DIVIDERS

Contoured Shelving Unit with Dividers

Aluminum



ProMaster
City

SH36-3	15" D x 36" W x 45" H	41 lbs	3 shelves (13", 12", 8")	12	7728	1 hr	Yes
SH48-3	15" D x 48" W x 45" H	49 lbs	3 shelves (13", 12", 8")	18	7725	1 hr	No
SH60-3	15" D x 60" W x 45" H	58 lbs	3 shelves (13", 12", 8")	21	7727	1 hr	Yes



Contoured Shelving Unit with Dividers

Aluminum



ProMaster
City

SH36-4	15" D x 36" W x 45" H	50 lbs	4 shelves (13", 13", 12", 8")	16	7723	1 hr	No
SH48-4	15" D x 48" W x 45" H	62 lbs	4 shelves (13", 13", 12", 8")	16	7720	1 hr	No
SH60-4	15" D x 60" W x 45" H	74 lbs	4 shelves (13", 13", 12", 8")	28	7722	1 hr	No



Contoured Shelving Unit with Dividers

Aluminum



Metris















SL36-3	14" D x 36" W x 46" H	44 lbs	3 shelves (11", 13", 13")	12	7723	1 hr	Yes
SL48-3	14" D x 48" W x 46" H	53 lbs	3 shelves (11", 13", 13")	18	7720	1 hr	No
SL60-3	14" D x 60" W x 46" H	62 lbs	3 shelves (11", 13", 13")	21	7722	1 hr	Yes
SL72-3	14" D x 72" W x 46" H	73 lbs	3 shelves (11", 13", 13")	27	7723	1 hr	Yes



SHELVING – DEEP SQUARE BACK BIN SHELVING UNIT

Deep Square Back Bin Shelving Unit















Steel

								
	Box Truck	Transit High Roof	Transit Medium Roof	Sprinter High Roof	Sprinter Low Roof	NV High Roof	ProMaster High Roof	ProMaster
								
H38-T	17" D x 38" W x 58" H	93 lbs	4 Shelves (13", 16", 16", 16")	6	Y11-D	1 hr	No	
H42-T	17" D x 42" W x 58" H	100 lbs	4 Shelves (13", 16", 16", 16")	9	Y11-F	1 hr	No	
H56-T	17" D x 56" W x 58" H	120 lbs	4 Shelves (13", 16", 16", 16")	12	Y11-J	1 hr	No	
H70-T	17" D x 70" W x 58" H	140 lbs	4 Shelves (13", 16", 16", 16")	12	Y11-C	1 hr	No	



Deep Square Back Bin Shelving Unit















Steel

								
	Box Truck	Transit High Roof	Transit Medium Roof	Sprinter High Roof	Sprinter Low Roof	NV High Roof	ProMaster High Roof	ProMaster
								
H87-T	17" D x 87" W x 58" H	165 lbs	4 Shelves (13", 16", 16", 16")	15	Y11-F	1 hr	No	



Deep Square Back Shelving Unit

Steel

								
	Box Truck	Transit High Roof	Transit Medium Roof	Sprinter High Roof	Sprinter Low Roof	NV High Roof	ProMaster High Roof	ProMaster
								
L38-T	17" D x 38" W x 58" H	88 lbs	5 Shelves (14", 16", 16", 16", 16")			Y10-D	1 hr	No
L42-T	17" D x 42" W x 58" H	93 lbs	5 Shelves (14", 16", 16", 16", 16")			Y10-F	1 hr	No
L56-T	17" D x 56" W x 58" H	112 lbs	5 Shelves (14", 16", 16", 16", 16")			Y10-B	1 hr	No
L70-T	17" D x 70" W x 58" H	130 lbs	5 Shelves (14", 16", 16", 16", 16")			Y10-C	1 hr	No

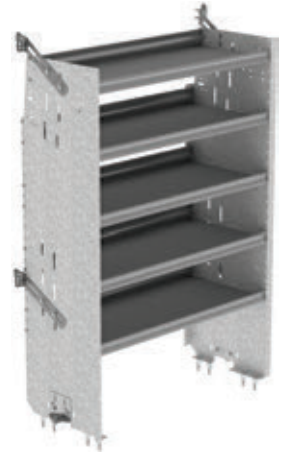

SHELVINGS

SHELVING – DEEP SQUARE BACK SHELVING UNIT

Deep Square Back Shelving Unit

Steel



Box Truck Transit High Roof Transit Medium Roof Sprinter High Roof Sprinter Low Roof NV High Roof ProMaster High Roof ProMaster



L87-T 17" D x 87" W x 58" H 154 lbs 5 Shelves (14", 16", 16", 16", 16") Y10-F 1 hr No



Deep Square Back Shelving Unit with Dividers

Steel



Box Truck Transit High Roof Transit Medium Roof Sprinter High Roof Sprinter Low Roof NV High Roof ProMaster High Roof ProMaster



F38-T 17.5" D x 38" W x 58" H 80 lbs 4 Shelves (14", 16", 16", 16") 6 Y11-D 1 hr No

F42-T 17.5" D x 42" W x 58" H 85 lbs 4 Shelves (14", 16", 16", 16") 6 Y11-F 1 hr No

F56-T 17.5" D x 56" W x 58" H 101 lbs 4 Shelves (14", 16", 16", 16") 12 Y11-J 1 hr No

F70-T 17.5" D x 70" W x 58" H 115 lbs 4 Shelves (14", 16", 16", 16") 12 Y11-C 1 hr No

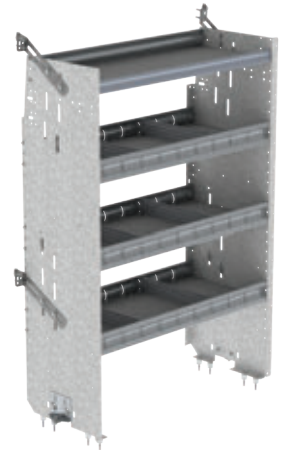

Deep Square Back Shelving Unit with Dividers

Steel



Box Truck Transit High Roof Transit Medium Roof Sprinter High Roof Sprinter Low Roof NV High Roof ProMaster High Roof ProMaster



F87-T 17.5" D x 87" W x 58" H 136 lbs 4 Shelves (14", 16", 16", 16") 15 Y11-F 1 hr No









SHELVING

SHELVING – FOLD-AWAY SHELF TRAY WITH GAS SHOCKS AND HARDWARE

Fold-Away Shelf Tray with Gas Shocks and Hardware

Aluminum

							
84-1830	18" D x 30" W	15 lbs	17"			0.4 hr	No
84-1836	18" D x 36" W	17 lbs	17"			0.4 hr	Yes
84-1848	18" D x 48" W	18 lbs	17"			0.4 hr	No
84-1858	18" D x 58" W	21 lbs	17"			0.4 hr	No
84-1872	18" D x 72" W	26 lbs	17"			0.44 hr	Yes
84-2130	21" D x 30" W	16 lbs	20"			0.4 hr	No
84-2136	21" D x 36" W	17 lbs	20"			0.4 hr	Yes
84-2148	21" D x 48" W	20 lbs	20"			0.4 hr	Yes
84-2158	21" D x 58" W	23 lbs	20"			0.43 hr	Yes
84-2172	21" D x 72" W	28 lbs	20"			0.46 hr	Yes







Weight capacity for fold-away shelving is 65 lbs / linear foot.

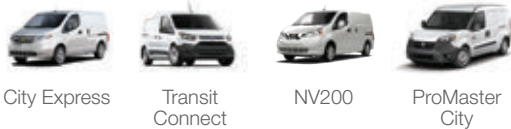

Fold-Away Shelving

Aluminum



							
8330-2	18" D x 37" W x 46.5" H	45 lbs	2 Shelves (17", 17")			1.3 hrs	Yes
8348-2	18" D x 55" W x 46.5" H	52 lbs	2 Shelves (17", 17")			1.31 hrs	No







Weight capacity for fold-away shelving is 65 lbs / linear foot.



Fold-Away Shelving

Aluminum



							
8436-2	21" D x 43" W x 63.5" H	42 lbs	2 Shelves (20", 20")			1.2 hrs	No
8448-2	21" D x 55" W x 63.5" H	58 lbs	2 Shelves (20", 20")			1.2 hrs	Yes
8458-2	21" D x 65" W x 63.5" H	64 lbs	2 Shelves (20", 20")			1.3 hrs	Yes
8472-2	21" D x 79" W x 63.5" H	74 lbs	2 Shelves (20", 20")			1.4 hrs	Yes

Weight capacity for fold-away shelving is 65 lbs / linear foot.



SHELVING – FOLD-AWAY SHELVING

Fold-Away Shelving

Aluminum



	Box Truck	Transit High Roof	Transit Medium Roof	Sprinter High Roof	NV High Roof	ProMaster High Roof	ProMaster Does not fit over wheel well in ProMaster.
8448-3	21" D × 55" W × 72" H	74 lbs	3 Shelves (17", 17", 20")				2.5 hrs
8458-3	21" D × 65" W × 72" H	83 lbs	3 Shelves (17", 17", 20")				2.7 hrs
8472-3	21" D × 79" W × 72" H	98 lbs	3 Shelves (17", 17", 20")				2.7 hrs

Weight capacity for fold-away shelving is 65 lbs / linear foot.



Fold-Away Shelving

Aluminum



	Express	E-Series	Transit Low Roof	Savana	NV Low Roof		
8548-2	18" D × 55" W × 53.5" H	52 lbs	2 Shelves (17", 17")				2.2 hrs
8558-2	18" D × 65" W × 53.5" H	59 lbs	2 Shelves (17", 17")				2.4 hrs
8572-2	18" D × 79" W × 53.5" H	70 lbs	2 Shelves (17", 17")				2.4 hrs

Weight capacity for fold-away shelving is 65 lbs / linear foot.



Fold-Away Shelving

Aluminum



Metris

8636-2	18" D × 43" W × 50.5" H	42 lbs	2 Shelves (17", 17")				2.6 hrs
8658-2	18" D × 65" W × 50.5" H	46 lbs	2 Shelves (17", 17")				2.6 hrs

Weight capacity for fold-away shelving is 65 lbs / linear foot.



Mounting Bar Assembly for Fold-Away Shelving

Aluminum



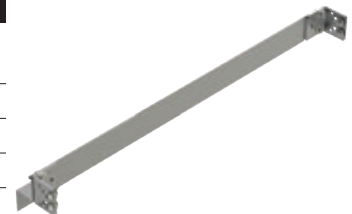



84-3033	2" D × 33" W	3 lbs					0.1 hr
84-3039	2" D × 39" W	3 lbs					0.1 hr
84-3051	2" D × 51" W	4 lbs					0.11 hr
84-3061	2" D × 61" W	5 lbs					0.12 hr
84-3075	2" D × 75" W	6 lbs					0.14 hr



SHELVING – POST ASSEMBLY FOR FOLD-AWAY SHELVING

Post Assembly for Fold-Away Shelving

Aluminum

							
84-7045	2" D × 2" W × 45.5" H	6 lbs				0.2 hr	No
84-7051	2" D × 2" W × 51.5" H	6 lbs				0.2 hr	Yes
84-7063	2" D × 2" W × 63.5" H	7 lbs				0.2 hr	Yes









Square Back Bin Shelving Unit

Aluminum



C/V

							
5136	10.5" D × 36" W × 32" H	40 lbs			9(sm), 18(md)	1 hr	Yes
5148	10.5" D × 48" W × 32" H	48 lbs			12(sm), 24(md)	1 hr	No
5160	10.5" D × 60" W × 32" H	58 lbs			15(sm), 30(md)	1 hr	No

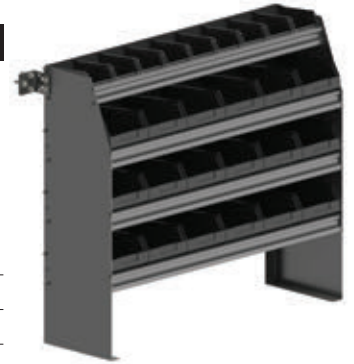







Square Back Bin Shelving Unit

Aluminum









Box Truck

							
7336	15" D × 36" W × 58.5" H	58 lbs			18(sm), 12(md), 8(lrg)	1 hr	No
7348	15" D × 48" W × 58.5" H	70 lbs			24(sm), 16(md), 12(lrg)	1 hr	No
7360	15" D × 60" W × 58.5" H	82 lbs			30(sm), 20(md), 14(lrg)	1 hr	No



Square Back Bin Shelving Unit

Aluminum

							
7848	11" D × 48" W × 13.25" H	25 lbs	2 Shelves (9", 9")		16(md)	0.5 hr	No



SHELVING – SQUARE BACK BIN SHELVING UNIT

Square Back Bin Shelving Unit

Aluminum



Box Truck



9148	13.5" D x 48" W x 62.5" H	103 lbs			56 (md)	1.1 hrs	No
9160	13.5" D x 60" W x 62.5" H	125 lbs			70 (md)	1.1 hrs	No

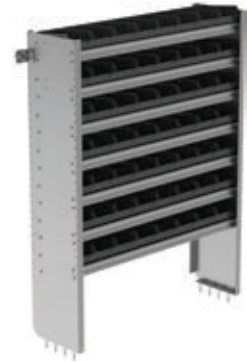

Square Back Bin Shelving Unit

Steel



C/V



H38-G	14" D x 38" W x 32" H	47 lbs	2 Shelves (13", 13")	3	4	1 hr	No
H42-G	14" D x 42" W x 32" H	51 lbs	2 Shelves (13", 13")	3	5	1 hr	No
H56-G	14" D x 56" W x 32" H	61 lbs	2 Shelves (13", 13")	4	7	1 hr	No
H70-G	14" D x 70" W x 32" H	72 lbs	2 Shelves (13", 13")	4	8	1 hr	No



Square Back Bin Shelving Unit

Steel



Transit
Low Roof

NV
Low Roof



H38-R	14" D x 38" W x 46" H	63 lbs	3 Shelves (13", 13", 13")	6	4	1 hr	No
H42-R	14" D x 42" W x 46" H	68 lbs	3 Shelves (13", 13", 13")	6	5	1 hr	No
H56-R	14" D x 56" W x 46" H	81 lbs	3 Shelves (13", 13", 13")	8	7	1 hr	No
H70-R	14" D x 70" W x 46" H	95 lbs	3 Shelves (13", 13", 13")	8	8	1 hr	No



Square Back Bin Shelving Unit

Steel



Transit
Low Roof

NV
Low Roof



H87-R	14" D x 87" W x 46" H	116 lbs	3 Shelves (13", 13", 13")	12	10	1 hr	No
--------------	-----------------------	---------	---------------------------	----	----	------	----



SHELVING – SQUARE BACK BIN SHELVING UNIT

Square Back Bin Shelving Unit

Steel



Box Truck Transit High Roof Transit Medium Roof Sprinter High Roof Sprinter Low Roof NV High Roof ProMaster High Roof ProMaster



H38-X	14" D × 38" W × 58" H	80 lbs	4 Shelves (11", 13", 13", 13")	9	6	1 hr	No
H42-X	14" D × 42" W × 58" H	86 lbs	4 Shelves (11", 13", 13", 13")	9	7	1 hr	No
H56-X	14" D × 56" W × 58" H	103 lbs	4 Shelves (11", 13", 13", 13")	12	9	1 hr	No
H70-X	14" D × 70" W × 58" H	120 lbs	4 Shelves (11", 13", 13", 13")	12	11	1 hr	No

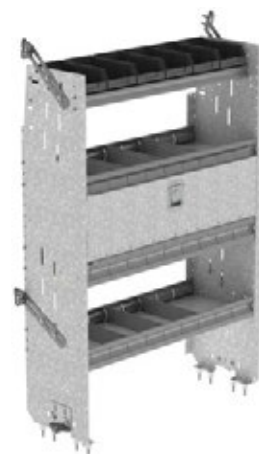

Square Back Bin Shelving Unit

Steel



Box Truck Transit High Roof Transit Medium Roof Sprinter High Roof Sprinter Low Roof NV High Roof ProMaster High Roof ProMaster



H87-X	14" D × 87" W × 58" H	145 lbs	4 Shelves (11", 13", 13", 13")	18	14	1 hr	No
--------------	-----------------------	---------	--------------------------------	----	----	------	----



Square Back Shelving Unit

Steel



C/V



L38-G	14" D × 38" W × 32" H	46 lbs	3 Shelves (13", 13", 13")			1 hr	Yes
L42-G	14" D × 42" W × 32" H	49 lbs	3 Shelves (13", 13", 13")			1 hr	No
L56-G	14" D × 56" W × 32" H	59 lbs	3 Shelves (13", 13", 13")			1 hr	No
L70-G	14" D × 70" W × 32" H	69 lbs	3 Shelves (13", 13", 13")			1 hr	No



SHELVINGS

SHELVING – SQUARE BACK SHELVING UNIT

Square Back Shelving Unit

Steel



Transit Low Roof NV Low Roof



L38-R	14" D x 38" W x 46" H	61 lbs	4 Shelves (13", 13", 13", 13")	1 hr	No
L42-R	14" D x 42" W x 46" H	65 lbs	4 Shelves (13", 13", 13", 13")	1 hr	Yes
L56-R	14" D x 56" W x 46" H	78 lbs	4 Shelves (13", 13", 13", 13")	1 hr	Yes
L70-R	14" D x 70" W x 46" H	91 lbs	4 Shelves (13", 13", 13", 13")	1 hr	No

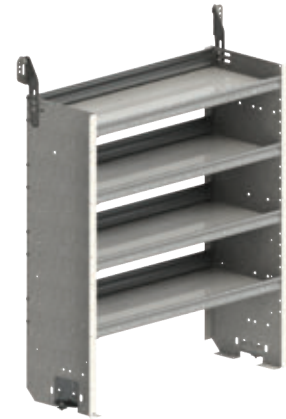

Square Back Shelving Unit

Steel

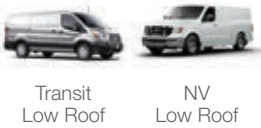

Transit Low Roof NV Low Roof



L87-R	14" D x 87" W x 46" H	113 lbs	4 Shelves (13", 13", 13", 13")	1 hr	No
--------------	-----------------------	---------	--------------------------------	------	----



Square Back Shelving Unit

Steel



Box Truck Transit High Roof Transit Medium Roof Sprinter High Roof Sprinter Low Roof NV High Roof ProMaster High Roof ProMaster



L38-X	14" D x 38" W x 58" H	78 lbs	5 Shelves (11", 13", 13", 13", 13")	1 hr	Yes
L42-X	14" D x 42" W x 58" H	82 lbs	5 Shelves (11", 13", 13", 13", 13")	1 hr	Yes
L56-X	14" D x 56" W x 58" H	99 lbs	5 Shelves (11", 13", 13", 13", 13")	1 hr	Yes
L70-X	14" D x 70" W x 58" H	115 lbs	5 Shelves (11", 13", 13", 13", 13")	1 hr	No



Square Back Shelving Unit

Steel



Box Truck Transit High Roof Transit Medium Roof Sprinter High Roof Sprinter Low Roof NV High Roof ProMaster High Roof ProMaster



L87-X	14" D x 87" W x 58" H	141 lbs	5 Shelves (11", 13", 13", 13", 13")	1 hr	No
--------------	-----------------------	---------	-------------------------------------	------	----



SHELVING

SHELVING – SQUARE BACK SHELVING UNIT WITH DIVIDERS

Square Back Shelving Unit with Dividers

Aluminum



CV



4336-2	13.5" D x 36" W x 29.5" H	28 lbs	2 Shelves (12", 12")	8	7723	0.8 hr	No
4348-2	13.5" D x 48" W x 29.5" H	34 lbs	2 Shelves (12", 12")	12	7720	0.8 hr	Yes
4360-2	13.5" D x 60" W x 29.5" H	40 lbs	2 Shelves (12", 12")	16	7722	0.8 hr	No
4372-2	13.5" D x 72" W x 29.5" H	46 lbs	2 Shelves (12", 12")	16	7723	1 hr	No



Square Back Shelving Unit with Dividers

Aluminum



CV



4536-3	13.5" D x 36" W x 38" H	36 lbs	3 Shelves (12", 12", 12")	18	7723	1 hr	No
4548-3	13.5" D x 48" W x 38" H	44 lbs	3 Shelves (12", 12", 12")	18	7720	1 hr	No
4560-3	13.5" D x 60" W x 38" H	52 lbs	3 Shelves (12", 12", 12")	24	7722	1 hr	No



Square Back Shelving Unit with Dividers

Aluminum



Box Truck



4848-4	16.5" D x 48" W x 62.5" H	68 lbs	4 Shelves (15", 15", 15", 15")	24	7730	1.2 hrs	No
4860-4	16.5" D x 60" W x 62.5" H	80 lbs	4 Shelves (15", 15", 15", 15")	32	7732	1.2 hrs	No

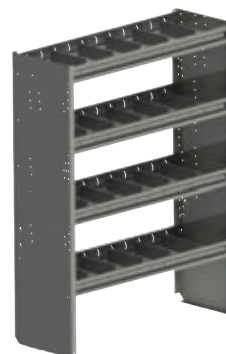

Square Back Shelving Unit with Dividers

Aluminum



Box Truck



4848-5	16.5" D x 48" W x 62.5" H	80 lbs	5 Shelves (15", 15", 15", 15", 15")	30	7720	1.2 hrs	No
4860-5	16.5" D x 60" W x 62.5" H	95 lbs	5 Shelves (15", 15", 15", 15", 15")	40	7722	1.2 hrs	No



SHELVING – SQUARE BACK SHELVING UNIT WITH DIVIDERS

Square Back Shelving Unit with Dividers

Aluminum



Box Truck



4872-4	16.5" D x 72" W x 62.5" H	90 lbs	4 Shelves (15", 15", 15", 15")	32	7733	1.2 hrs	No
4884-4	16.5" D x 84" W x 62.5" H	116 lbs	4 Shelves (15", 15", 15", 15")		N/A	1.2 hrs	No
4896-4	16.5" D x 96" W x 62.5" H	116 lbs	4 Shelves (15", 15", 15", 15")	48	7730	1.2 hrs	No



Square Back Shelving Unit with Dividers

Aluminum



Box Truck



4872-5	16.5" D x 72" W x 62.5" H	108 lbs	5 Shelves (15", 15", 15", 15", 15")	40	7723	1.2 hrs	No
4884-5	16.5" D x 84" W x 62.5" H	140 lbs	5 Shelves (15", 15", 15", 15", 15")		N/A	1.2 hrs	No
4896-5	16.5" D x 96" W x 62.5" H	140 lbs	5 Shelves (15", 15", 15", 15", 15")	60	7720	1.2 hrs	No



Square Back Shelving Unit with Dividers

Aluminum



Box Truck



9048-4	13.5" D x 48" W x 62.5" H	67 lbs	4 Shelves (12", 12", 12", 12")	24	7730	1.1 hrs	No
9060-4	13.5" D x 60" W x 62.5" H	80 lbs	4 Shelves (12", 12", 12", 12")	32	7732	1.1 hrs	No



Square Back Shelving Unit with Dividers

Aluminum



Box Truck



9048-5	13.5" D x 48" W x 62.5" H	80 lbs	5 Shelves (12", 12", 12", 12", 12")	30	7720	1.1 hrs	No
9060-5	13.5" D x 60" W x 62.5" H	95 lbs	5 Shelves (12", 12", 12", 12", 12")	40	7722	1.1 hrs	No



SHELVING – SQUARE BACK SHELVING UNIT WITH DIVIDERS

Square Back Shelving Unit with Dividers

Aluminum



Box Truck



9072-4	13.5" D × 72" W × 62.5" H	92 lbs	4 Shelves (12", 12", 12", 12")	32	7733	1.1 hrs	No
9084-4	13.5" D × 84" W × 62.5" H	105 lbs	4 Shelves (12", 12", 12", 12")	40	N/A	1.1 hrs	No
9096-4	13.5" D × 96" W × 62.5" H	117 lbs	4 Shelves (12", 12", 12", 12")	48	7730	1.1 hrs	No



Square Back Shelving Unit with Dividers

Aluminum



Box Truck



9072-5	13.5" D × 72" W × 62.5" H	111 lbs	5 Shelves (12", 12", 12", 12", 12")	40	7723	1.1 hrs	No
9084-5	13.5" D × 84" W × 62.5" H	127 lbs	5 Shelves (12", 12", 12", 12", 12")	50	N/A	1.1 hrs	No
9096-5	13.5" D × 96" W × 62.5" H	142 lbs	5 Shelves (12", 12", 12", 12", 12")	60	7720	1.1 hrs	No

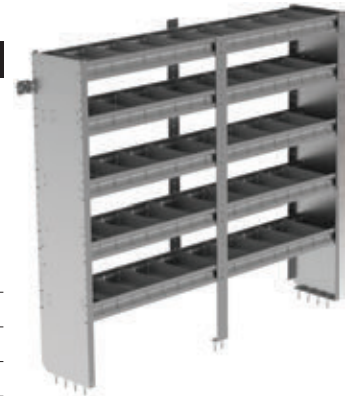

Square Back Shelving Unit with Dividers

Steel



C/V



F38-G	14" D × 38" W × 32" H	38 lbs	2 Shelves (13", 13")	3	Y11-D	1 hr	Yes
F42-G	14" D × 42" W × 32" H	39 lbs	2 Shelves (13", 13")	3	Y11-F	1 hr	No
F56-G	14" D × 56" W × 32" H	46 lbs	2 Shelves (13", 13")	4	Y11-J	1 hr	No
F70-G	14" D × 70" W × 32" H	53 lbs	2 Shelves (13", 13")	4	Y11-C	1 hr	No



SHELVING – SQUARE BACK SHELVING UNIT WITH DIVIDERS

Square Back Shelving Unit with Dividers

Steel

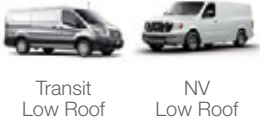

F38-R	14" D x 38" W x 46" H	63 lbs	3 Shelves (13", 13", 13")	6	Y12-D	1 hr	No
F42-R	14" D x 42" W x 46" H	66 lbs	3 Shelves (13", 13", 13")	6	Y12-F	1 hr	No
F56-R	14" D x 56" W x 46" H	81 lbs	3 Shelves (13", 13", 13")	8	Y12-J	1 hr	No
F70-R	14" D x 70" W x 46" H	94 lbs	3 Shelves (13", 13", 13")	8	Y12-C	1 hr	No



Square Back Shelving Unit with Dividers

Steel



F87-R	14" D x 87" W x 46" H	118 lbs	3 Shelves (13", 13", 13")	12	Y12-F	1 hr	Yes



Square Back Shelving Unit with Dividers

Steel



F38-X	14" D x 38" W x 58" H	70 lbs	4 Shelves (11", 13", 13", 13")	9	Y12-D	1 hr	No
F42-X	14" D x 42" W x 58" H	74 lbs	4 Shelves (11", 13", 13", 13")	9	Y12-F	1 hr	Yes
F56-X	14" D x 56" W x 58" H	88 lbs	4 Shelves (11", 13", 13", 13")	12	Y12-J	1 hr	Yes
F70-X	14" D x 70" W x 58" H	102 lbs	4 Shelves (11", 13", 13", 13")	12	Y12-C	1 hr	Yes



Square Back Shelving Unit with Dividers

Steel



F87-X	14" D x 87" W x 58" H	125 lbs	4 Shelves (11", 13", 13", 13")	18	Y12-F	1 hr	Yes



SHELVING



Shelving Doors

Aluminum					
		Use with shelf width			
7720	44.88" W x 8.69" H	48", 96"	7 lbs	0.5 hr	No
7722	56.88" W x 8.69" H	60"	9 lbs	0.5 hr	No
7723	32.88" W x 8.69" H	36", 72"	5 lbs	0.5 hr	No
7724	20.88" W x 8.69" H	24"	4 lbs	0.5 hr	No
7725	44.88" W x 10.38" H	48", 96"	8 lbs	0.5 hr	Yes
7727	56.88" W x 10.38" H	60"	9 lbs	0.5 hr	No
7728	32.88" W x 10.38" H	36", 72"	6 lbs	0.5 hr	Yes
7729	20.88" W x 10.38" H	24"	4 lbs	0.5 hr	No
7730	44.88" W x 12.06" H	48", 96"	8 lbs	0.5 hr	Yes
7731	38.88" W x 12.06" H	84"	8 lbs	0.5 hr	No
7732	56.88" W x 12.06" H	60"	10 lbs	0.5 hr	No
7733	32.88" W x 12.06" H	36", 72"	6 lbs	0.5 hr	No
7734	20.88" W x 12.06" H	24"	5 lbs	0.5 hr	No
7735	44.88" W x 13.75" H	48", 96"	9 lbs	0.5 hr	No
7737	56.88" W x 13.75" H	60"	11 lbs	0.5 hr	No
7738	32.88" W x 13.75" H	36", 72"	7 lbs	0.5 hr	No
7739	20.88" W x 13.75" H	24"	5 lbs	0.5 hr	No



Shelf Block

Aluminum					
		Use with shelf width			
7740	12" W x Adjustable from 1 1/4" to 6 5/16"	All	3 lbs	0.5 hr	No



Shelving Doors

Steel					
		Use with shelf width			
Y10-C	34.88" W x 8.69" H	70"	9 lbs	0.5 hr	Yes
Y10-D	37.88" W x 8.69" H	38"	10 lbs	0.5 hr	No
Y10-F	41.88" W x 8.69" H	42", 87"	12 lbs	0.5 hr	Yes
Y10-H	47.88" W x 8.69" H	48"	14 lbs	0.5 hr	No
Y10-M	31.88" W x 8.69" H	32"	8 lbs	0.5 hr	No
Y11-C	34.88" W x 10.38" H	70"	10 lbs	0.5 hr	Yes
Y11-D	37.88" W x 10.38" H	38"	11 lbs	0.5 hr	Yes
Y11-E	35.88" W x 10.38" H	36"	10.5 lbs	0.5 hr	No
Y11-F	41.88" W x 10.38" H	42", 87"	13 lbs	0.5 hr	Yes
Y11-M	31.88" W x 10.38" H	32"	8 lbs	0.5 hr	No
Y12-C	34.88" W x 12.06" H	70"	10 lbs	0.5 hr	No
Y12-D	37.88" W x 12.06" H	38"	12 lbs	0.5 hr	No
Y12-F	41.88" W x 12.06" H	42", 87"	14 lbs	0.5 hr	No
Y12-M	31.88" W x 12.06" H	32"	8 lbs	0.5 hr	No



Shelving Doors

Steel					
		Use with shelf width			
Y10-J	55.88" W x 8.69" H	56"	15 lbs	0.5 hr	No
Y11-J	55.88" W x 10.38" H	56"	16 lbs	0.5 hr	No
Y12-J	55.88" W x 12.06" H	56"	17 lbs	0.5 hr	No

LOCKERS & WORKBENCHES

7111

Contoured locker w/top shelf

Aluminum



Sprinter



16" D x 14" W x 62.5" H



35 lbs



1 hr



No

7119

Square back locker w/top shelf

Aluminum



Box Truck



16.5" D x 14" W x 62.5" H



39 lbs



1 hr



No

7115

Locker w/top shelf

Aluminum



Transit
Low Roof



NV
Low Roof



16.5" D x 14" W x 43.5" H



30 lbs



1 hr



Yes

7120

Locker w/top shelf

Aluminum



Transit
Med/High Roof



NV
High Roof



ProMaster



15.5" D x 14" W x 62.5" H



35 lbs



1 hr



Yes

7118

Contoured locker w/top shelf

Aluminum



Express



E-Series



16.5" D x 14" W x 43" H



30 lbs



1 hr



No

7207

Workbench w/hardwood top,
no shelves

Aluminum

UNIVERSAL



18" D x 48" W x 36" H



54 lbs



0.5 hr



No

SHELVING

LOCKERS & WORKBENCHES

7208

Workbench w/hardwood top, one end panel
(Drawer cabinet not included)

Aluminum

UNIVERSAL



18" D x 48" W x 36" H



47 lbs



0.5 hr



No

7211

Workbench w/hardwood top, 2 bin shelves

Aluminum

UNIVERSAL



18" D x 48" W x 36" H



75 lbs



1 hr



No

7209

Workbench w/hardwood top, 1 shelf

Aluminum

UNIVERSAL



18" D x 48" W x 36" H



65 lbs



1 hr



Yes

7247

Workbench w/hardwood top, one end panel
(Drawer cabinet not included)

Aluminum

UNIVERSAL



18" D x 48" W x 28" H



47 lbs



1 hr



No

7210

Workbench w/hardwood top, 1 shelf w/door

Aluminum

UNIVERSAL



18" D x 48" W x 36" H



75 lbs



1.2 hrs



No

7248

Workbench w/hardwood top, 2 bin shelves

Aluminum

UNIVERSAL



18" D X 48" W X 28" H



75 lbs



1 hr



Yes

LOCKERS & WORKBENCHES

J48-X

Square back unit with 1 open shelf & 1 workbench

Steel



Transit Med/High Roof Sprinter NV High Roof Box Truck ProMaster



14" D x 48" W x 58" H



85 lbs



1 hr



No

K48-X

Square back unit with 1 open shelf, 1 workbench & 1 pull out drawer

Steel



Transit Med/High Roof Sprinter NV High Roof Box Truck ProMaster



14" D x 48" W x 58" H



105 lbs



1 hr



No

SHELVING



7208 Workbench with hardwood top mounted with a **5060-5** 5 Drawer cabinet

WORKBENCH: A HANDY WORK STATION FOR ANY TASK





DRAWERS

Durable storage compartments,
designed for quick and easy access.



TOUGH

Proline drawers are backed by a 10 year warranty.



QUICK

Easy to use slam latch.



SECURE

Keyed lock to guard valuables.

DRAWERS

- AXESS TRAYS. P. 214
- CAB BOXES P. 216
- PARTSLIDER DRAWERS. P. 217
- TOP EDGES P. 217
- DRAWER CABINETS. P. 219
- COMPACT DRAWERS P. 220
- PARTSKEEPERS. P. 221
- TOOL DRAWERS P. 222

Ranger Design manufactures a variety of tough, quiet drawer systems and storage modules. Using top quality components such as full-extension, high-capacity ball-bearing drawer slides, secure locks, and Ranger Design’s unique braided stainless steel cable-pull handles. These drawers are the organizational quality that you deserve.

If you never again want to experience the frustration of drawers that jam, sag, and don’t latch properly, we have the solution.



DRAWERS



5032-0

Axess Tray with 1 shelf / no drawers

Aluminum

38" D x 45" W x 30" H



51 lbs



0.9 hr



No



5032-1

Axess Tray with 1 shelf / 1 drawer

Aluminum

38" D x 45" W x 30" H



200 lbs



89 lbs



1 hr



Yes



5032-2

Axess Tray with 1 shelf / 2 drawers

Aluminum

38" D x 45" W x 30" H



200 lbs



127 lbs



1.1 hrs



No



5032-3

Axess Tray with 1 shelf / 3 drawers

Aluminum

38" D x 45" W x 30" H



200 lbs



165 lbs



1.2 hrs



No



5032-A

Axess Tray drawer only,
complete with slides

Aluminum

38" D x 45" W



38 lbs



38 lbs



1 hr



No

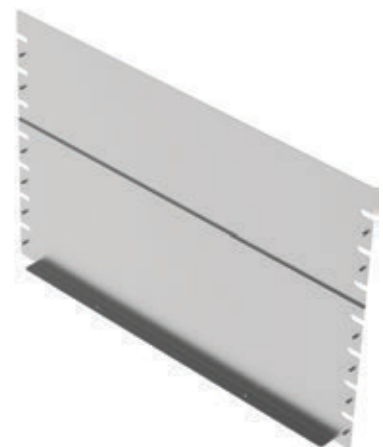

5032-F

Axess Tray full back panel for 5032 series

Aluminum

41" W x 27.25" H



8 lbs



0.25 hr



No



5032-1 Axxess Tray with 1 shelf / 1 drawer



5037-0

Axxess Tray with 1 shelf / no drawers

Aluminum

 38" D x 45" W x 42" H



55 lbs



1 hr



No



5037-1

Axxess Tray with 1 shelf / 1 drawer

Aluminum

 38" D x 45" W x 42" H



200 lbs



93 lbs



1.1 hrs



No



5037-2

Axxess Tray with 1 shelf / 2 drawers

Aluminum

 38" D x 45" W x 42" H



200 lbs



131 lbs



1.2 hrs



No



5037-3

Axxess Tray with 1 shelf / 3 drawers

Aluminum

 38" D x 45" W x 42" H



200 lbs



169 lbs



1.3 hrs



No



DRAWERS

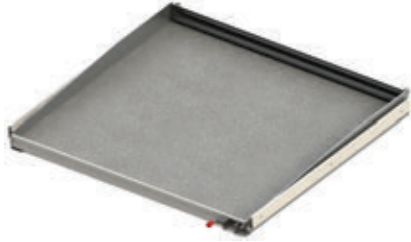

5037-A

Axess Tray drawer only, c/w slides

Aluminum

38" D × 45" W



38 lbs



No

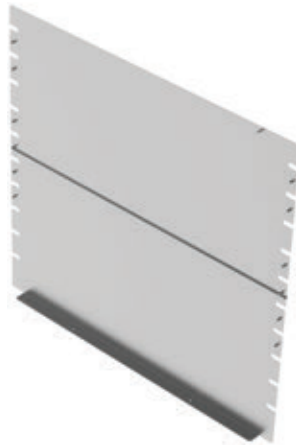

5037-F

Axess Tray full back panel for 5037 series

Aluminum

41" W × 39.25" H



11 lbs



0.25 hr



No



5040

Cab box with locking lid, Narrow

Aluminum

20" D × 6.5" W × 15.75" H



11 lbs



0.5 hr



No

DRAWERS



5041

Raised base for 5040 cab box, Transit

Steel



No



5044

Raised base for 5045 cab box, Sprinter

Aluminum

9" H



2 lbs



0.2 hr



No



5045

Cab box with locking lid

Aluminum

18" D × 12" W × 16" H



16 lbs



0.4 hr



No



5047

Raised base for ProMaster cab box

Aluminum

20.5" D x 13" W x 5.5" H



4 lbs



0.2 hr



No



5058

Raised base for GM Van cab box

Aluminum

3.5" H



4 lbs



No



No

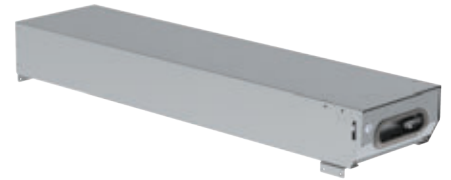

5010

Partslider drawer

Aluminum

48" D x 12" W x 6" H



150 lbs



30 lbs



0.5 hr



Yes



5011

Partslider drawer

Aluminum

36" D x 12" W x 6" H



150 lbs



26 lbs



0.5 hr



No



5014

Floor mount kit for 5010 / 5011 Partslider drawer

Aluminum



1 lb



No



No



5048

Top edge, for 5010 Partslider

Aluminum

48" D x 12" W x 4" H



5 lbs



0.2 hr



Yes



DRAWERS



5049

Top edge, for 5020 Tool Drawer

Aluminum

48" D x 14" W x 4" H



5 lbs



0.2 hr



No



5048 Top edge, for 5010 Partslider



5050

Top edge, for 5025 Tool Drawer

Aluminum

48" D x 16" W x 4" H



5 lbs



0.2 hr



No



5051

Top edge, for 5011 Partslider

Aluminum

36" D x 12" W x 4" H



4 lbs



0.2 hr



No



5052

Top edge, for 5021 Tool Drawer

Aluminum

36" D x 14" W x 4" H



4 lbs



0.2 hr



No



5053

Top edge, for 5026 Tool Drawer

Aluminum

36" D x 16" W x 4" H



4 lbs

0.2 hr

No



5057

Top edge, for 5060 Drawer Cabinet

Aluminum

18" D x 24" W x 4" H



4 lbs

0.2 hr

No



5060-5

5 Drawer cabinet and one door

Aluminum

18" D x 24" W x 36" H

150 lbs

104 lbs

1 hr

No



5060-6

6 Drawer cabinet

Aluminum

18" D x 24" W x 36" H

150 lbs

114 lbs

1 hr

No



5060-8

8 Drawer cabinet

Aluminum

18" D x 24" W x 36" H

150 lbs

148 lbs

1 hr

No



5065-8

8 Drawer cabinet, square back

Aluminum

19" D x 24" W x 56" H

150 lbs

168 lbs

1 hr

No



DRAWERS



5066-8
8 Drawer cabinet, contoured

Aluminum	
20.5" D x 24" W x 56" H	
150 lbs	
168 lbs	
1 hr	
No	



5067-6
6 Drawer cabinet

Aluminum	
18" D x 18" W x 28" H	
150 lbs	
97 lbs	
0.5 hr	
No	



5068-3
3 Drawer cabinet

Aluminum	
18" D x 15" W x 15" H	
150 lbs	
45 lbs	
0.5 hr	
Yes	



5069-2
2 Drawer cabinet

Aluminum	
14" D x 24" W x 12" H	
150 lbs	
34 lbs	
0.5 hr	
Yes	



X50-B
Compact 2-Drawer Unit

Steel	
12.5" D x 18.5" W x 10.5" H	
19 lbs	
19 lbs	
0.3 hr	
Yes	



X50-C
Compact 3-Drawer Unit

Steel	
12.5" D x 18.5" W x 10.5" H	
20 lbs	
20 lbs	
0.3 hr	
Yes	

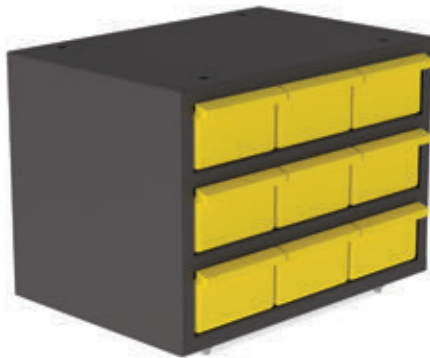

X51-F

Compact 9-Drawer Unit

Steel

12" D x 17" W x 12" H



26 lbs



0.3 hr



Yes



5070

Partskeeper carry case with holder, universal

Aluminum

14" D x 17" W x 5.5" H



7 lbs



0.3 hr



Yes



5072

Partskeeper carry case with holder, floor mount

Aluminum

14" D x 17" W x 8.75" H



7 lbs



0.3 hr



No



5078

Partskeeper cabinet with 4 carry cases

Aluminum

14" D x 17" W x 24" H



23 lbs



0.3 hr



Yes



5070 Partskeeper carry case with holder, universal

DRAWERS

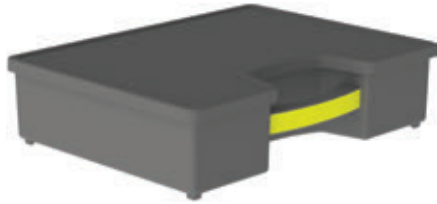

5079

Partskeeper carry case

Plastic

13" D x 16.5" W x 4" H



3 lbs



No



5082

Partskeeper cabinet with 8 carry cases

Aluminum

14" D x 17" W x 43" H



54 lbs



1 hr



Yes



5083

Partskeeper cabinet with 5 carry cases & 2 shelves

Aluminum

14" D x 17" W x 43" H



41 lbs



1 hr



Yes



X50-B & X-50 C Stacked



5086

Partskeeper cabinet with 8 carry cases & 2 shelves

Aluminum

14" D x 17" W x 62.5" H



65 lbs



1 hr



Yes



5020

Tool drawer

Aluminum

48" D x 14" W x 16" H



320 lbs



70 lbs



1 hr



Yes



5021

Tool drawer

Aluminum

36" D x 14" W x 16" H

320 lbs

60 lbs

1 hr

No



5025

Jumbo tool drawer

Aluminum

48" D x 16" W x 19" H

320 lbs

84 lbs

1 hr

Yes



5026

Jumbo tool drawer

Aluminum

36" D x 16" W x 19" H

320 lbs

73 lbs

1 hr

No



5028

Raised base for 5020 tool drawer

Aluminum

6" D x 14" W x 6" H

8 lbs

0.5 hr

No



5029

Raised base for 5025 Jumbo tool drawer

Aluminum

6" D x 16" W x 6" H

8 lbs

0.5 hr

No



X02-A

Fleetline Tool Drawer

Steel

45.5" D x 13.5" W x 22" H

80 lbs

1 hr

Yes





ACCESSORIES

Choose the finishing details to tailor the upfit to your specific needs.



VERSATILE

Removable storage bins ensure organization on the jobsite or on the go.



SECURE

Trade specific accessories with a place for all tools and supplies.



PRODUCTIVE

Stay productive with the most used items well within reach.

ACCESSORIES

- BINS P. 226
- BOTTLE HOLDERS P. 226
- LOCKING CABINETS P. 227
- HOOKS P. 228
- OTHERS P. 228
- PAPER HOLDERS P. 230
- SEAT COVERS P. 232
- STRAPS P. 230
- WINDOW GRILLS P. 231

The finishing details are just as important when you're setting up your commercial van as they are when you're on the job site.

Customize your vehicle with our wide range of options to ensure that you can perform with optimal efficiency.



ACCESSORIES



6205

Bin cup

Plastic

4.5" D x 3.25" W x 3.75" H

0.12 lb



No



6211

Small Bin, Graphite

Plastic

6.5" D x 4" W x 3" H

0.24 lb



Yes



6212

Divider for 6211 small bin

Aluminum



0 lb



No



6221

Medium Bin, Graphite

Plastic

10" D x 6" W x 4.5" H

0.56 lb



Yes



6222

Divider for 6221 medium bin

Aluminum



0 lb



No



6231

Large Bin, Graphite

Plastic

14" D x 8" W x 5.5" H

1.3 lbs



Yes



6231 Large Bin, Graphite



6232

Divider for 6231 large bin

Aluminum



0 lb



No



6001

4 Tier refrigerant rack for large bottles

14" D x 13" W x 62.5" H

34 lbs

0.7 hr

No



6002

5 Tier refrigerant rack for small bottles

14" D x 10.5" W x 62.5" H

36 lbs

0.7 hr

No



6003

5 Tier refrigerant rack for large bottles

14" D x 13" W x 62.5" H

36 lbs

0.7 hr

Yes



6006

3 Tier refrigerant rack for small bottles

Aluminum

14" D x 10.5" W x 43" H

24 lbs

0.6 hr

No



6007

4 Tier refrigerant rack for small bottles

Aluminum

14" D x 10.5" W x 43" H

22 lbs

0.6 hr

Yes



6008

3 Tier refrigerant rack for large bottles

Aluminum

14" D x 13" W x 43" H

25 lbs

0.6 hr

No



6010

Two level adjustable bottle holder

Aluminum

10.25" D x 9.5" W x 36" H

5 lbs

0.4 hr

No



6020

Horizontal refrigerant bottle holder

Aluminum

12.5" D x 48" W x 13" H

17 lbs

0.5 hr

No



6030

Bottle rack with straps

Aluminum

48" W

4 lbs

0.5 hr

No



6035

Bottle rack with straps

Aluminum

60" W

5 lbs

0.5 hr

No



6040

Locking cabinet

Aluminum

8.5" D x 12" W x 24" H

16 lbs

0.6 hr

No



6041

Locking cabinet

Aluminum

15" D x 15.5" W x 33" H

26 lbs

0.7 hr

No



6049

Ventilation kit for cabinet

Aluminum

0 lb

No



Y30-C Coat Hook, 1" opening, chrome plated

ACCESSORIES



6086

Small aluminum bottle holder, with a black nylon strap

Aluminum

6" W x 12" H

1 lb

0.2 hr

Yes



6088

Large aluminum bottle holder, with two black nylon straps

Aluminum

8" W x 24" H

2 lbs

0.2 hr

Yes



6070

6" Hook, 3" opening, painted

Steel

3" D

0.4 lb

0.2 hr

Yes



6072

8" Swivel Hook, 4" opening, painted

Steel

4" D

0.6 lb

0.2 hr

Yes



6073 Large aluminum movable hook, 6.5" opening



6073

Large aluminum movable hook, 6.5" opening

Aluminum

6.5" D x 2.75" W x 4" H

1 lb

0.01 hr

Yes



Y30-C

Coat Hook, 1" opening, chrome plated

Steel

1" D

0.1 lb

0.2 hr

Yes



1130

Elevated strobe mount

Aluminum

8" W

1 lb

0.1 hr

No

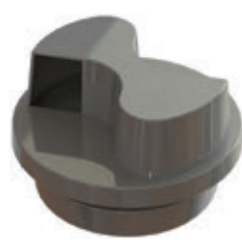

6050

Flettner vent, rotary design

Plastic

8.88" D

1.5 lbs

1 hr

No



6052

Vise Holder with an 8"x8" mounting plate

Steel

37 lbs

0.5 hr

No

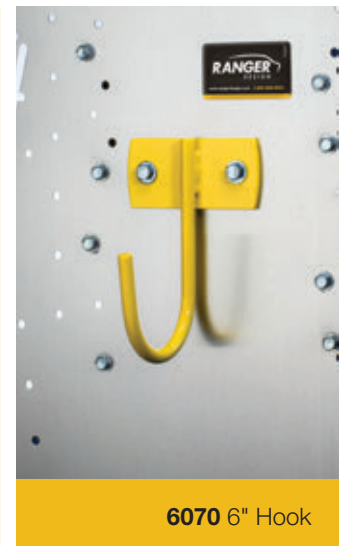

6070 6" Hook

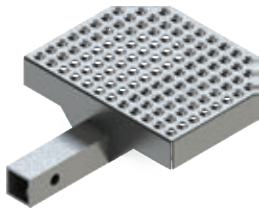

6054

Hitch Step, with hitch pin to fit a 2"x2" hitch

Aluminum

6" D x 12" W

4 lbs



No



6057

Can Holder

Aluminum

3" D x 8.5" W x 3" H

1 lb

0.2 hr

No



6075

Transport tube door, for 6" diameter tube with stainless steel hardware

Aluminum

6" D

2 lbs

0.2 hr

No



6078

Cradle & strap kit for 6" dia. transport tube (one cradle and one strap)

Aluminum

6" D

1 lb

0.1 hr

No

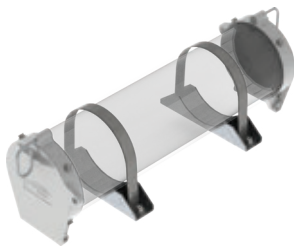

6079

Transport tube door kit complete (6" dia. PVC tube not included)

Aluminum

6" D

6 lbs

0.8 hr

No

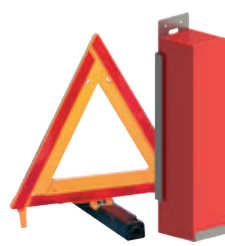

6082

Triangle kit with aluminum holder

Other

14 lbs

0.2 hr

No



6090

Back up alarm, die cast housing, fully encapsulated circuitry

Other

1 lb

1 hr

No



6091

Surface mount tie down ring, zinc plated

Steel

4" D

0.4 lb

0.2 hr

No



6092

Dome Light, chrome finish housing

Other

8.5" D

1 lb

1 hr

No



6093

Grab handle

Plastic

9.5" D

0.1 lb

0.5 hr

No



6090 Back up alarm, die cast housing

ACCESSORIES



7124

Reel Holder with two 5/8" diameter rods

Aluminum

7.25" D x 15" W x 24" H

9 lbs

0.5 hr

Yes



6061

Paper Holder, extra deep, 2 slots

Aluminum

3.75" D x 12.75" W x 12" H

2 lbs

0.2 hr

No

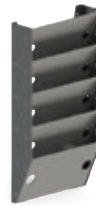

6063

Paper Holder, extra deep, 5 slots

Aluminum

3.75" D x 12.75" W x 24" H

5 lbs

0.2 hr

Yes



6066

2 Pocket Holder, with 8 plastic bins

Aluminum

4.5" D x 20" W x 21.75" H

7.5 lbs

0.2 hr

No



6067

Paper Holder, regular depth, 2 slots

Aluminum

2.25" D x 12.75" W x 12" H

2 lbs

0.2 hr

No



6068

Hard Hat Holder, painted wire

Steel

0.5 lb

0.2 hr

No



6069

Paper Holder, regular depth, 5 slots

Aluminum

2.25" D x 12.75" W x 24" H

5 lbs

0.2 hr

No

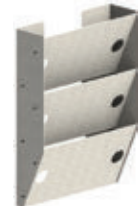

Y31-A

Paper Holder, extra deep, 3 slots

Steel

3.75" D x 12.75" W x 16" H

9 lbs

0.2 hr

Yes



6095

Black Nylon Strap, plastic buckle

Other

2" W x 28" H

0.18 lb

0.01 hr

No



6096

Black Nylon Strap, chrome plated buckle

Other

1" W x 36" H

0.12 lb

0.01 hr

No



6096 Black Nylon Strap, chrome plated buckle



6097

Black Nylon Strap,
chrome plated buckle

Other

1" W x 48" H

0.13 lb

0.01 hr

No



6098

Black Nylon Strap,
chrome plated buckle

Other

1" W x 72" H

0.16 lb

0.01 hr

No



6086 Small aluminum bottle holder, with a black nylon strap

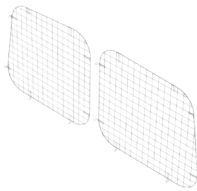

6106

Chevrolet Express & GMC Savana
Set of 2 rear window grills

Steel

Standard Roof

8 lbs

0.2 hr

No

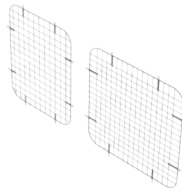

6111

Chevrolet Express & GMC Savana
Set of 2 side window grills

Steel

Standard Roof

8 lbs

0.2 hr

No

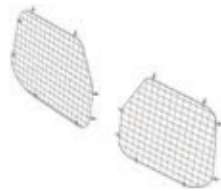

6120

Ford Transit
Set of 2 rear window grills

Steel

Low Roof

8 lbs

0.2 hr

No



6121

Ford Transit
Set of 2 rear window grills

Steel

Medium Roof

8 lbs

0.2 hr

No



6063 Paper Holder



6122

Ford Transit
Window grill, passenger
side sliding door

Steel

Low Roof

8 lbs

0.2 hr

No



6123

Ford Transit
Window grill, passenger
side sliding door

Steel

Medium Roof

8 lbs

0.2 hr

No

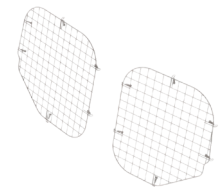

6124

Ford Transit Connect
Set of 2 rear window grills

Steel

Standard Roof

8 lbs

0.2 hr

No

ACCESSORIES

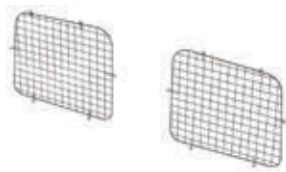

6126

Mercedes-Benz Metris
Set of 2 rear window grills

Steel

Standard Roof

5 lbs

0.2 hr

No

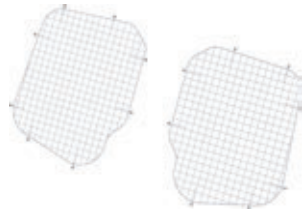

6107

Mercedes-Benz Sprinter
Set of 2 rear window grills

Steel

High Roof

8 lbs

0.2 hr

No



6117

Mercedes-Benz Sprinter
Window grill, passenger side sliding door

Steel

High Roof

8 lbs

0.2 hr

No

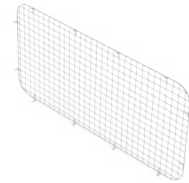

6118

Ram ProMaster
Window grill, passenger side sliding door (does not fit the 118" wheelbase)

Steel

High Roof

8 lbs

0.2 hr

No

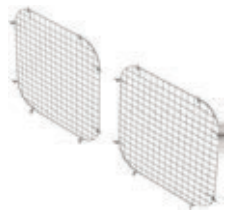

6119

Ram ProMaster
Set of 2 rear window grills

Steel

High Roof

11 lbs

0.2 hr

No

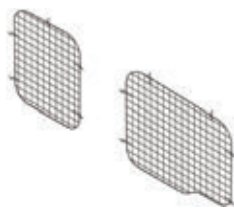

6134

Ram ProMaster City
Set of 2 rear window grills

Steel

Standard Roof

8 lbs

0.2 hr

No

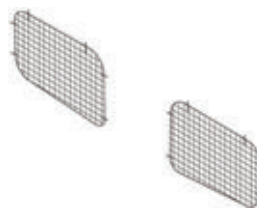

6135

Ram ProMaster City
Set of 2 sliding door window grills

Steel

Standard Roof

8 lbs

0.2 hr

No



3024

Universal Universal
Partition window with frame for 3020, 3025, 3068

Aluminum

Universal

5 lbs

0.5 hr

No

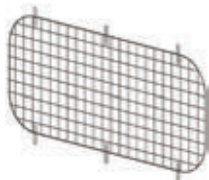

3044

Universal Universal
Grill for partition window for 3020, 3025, 3068

Steel

Universal

2 lbs

0.5 hr

No



7124 Reel Holder with two 5/8" diameter rods

SEAT COVERS



OUR KEY ADVANTAGES INCLUDE:

- Durable material and easy maintenance
- Urethane coating to make the fabric water and stain resistant
- Machine wash and dryer safe
- Easy installation within 30 minutes for a set
- No interference with factory seat functions (heat, cold, air bag)
- Minimal seams
- Tight custom fit for each vehicle guaranteed to stay in place
- Seat damage prevention puncture resistant
- Durable Cordura® fabric with a 1 year warranty

	PART #
CHEVROLET CITY EXPRESS NISSAN NV200	6251
CHEVROLET EXPRESS GMC SAVANA	6252
FORD TRANSIT	6255
FORD TRANSIT CONNECT	6256
NISSAN NV	6250
MERCEDES-BENZ METRIS	6258
MERCEDES-BENZ SPRINTER	6257
RAM PROMASTER	6254
RAM PROMASTER CITY	6253

SPECIFICATIONS

for 1 set of bucket seat covers

 4 lbs
 0.5 hr
 Yes

*We do not offer seat covers for bench seats



LADDER RACKS

Ergonomic Ladder Racks make loading and unloading easier.



TOUGH

Military grade aluminum extrusion, high density plastic and stainless steel components ensure no corrosion over the lifetime of the rack.



QUIET

Aerodynamic design with minimal wind noise.



SAFE

No metal contact to ladder, leading to longer life of ladders with less chance of fiberglass splinters.

LADDER RACKS

BOX TRUCK P. 238

CHEVROLET

CITY EXPRESS P. 238

EXPRESS P. 240

FORD

E-SERIES P. 241

TRANSIT P. 243

TRANSIT CONNECT P. 246

GMC

SAVANA P. 248

MERCEDES-BENZ

METRIS P. 249

SPRINTER P. 250

NISSAN

NV P. 253

NV200 P. 256

RAM

C/V P. 257

PROMASTER P. 258

PROMASTER CITY P. 262









Ranger ladder racks make loading and unloading ladders an easy operation. Ranger Design offers drop-down ladder racks for high roof vans, extra tough racks capable of carrying 28' ladders on compact vans, interior ladder carriers and many other options for different applications.

Please take note that all our ladder racks are powder-coated white.













LADDER RACKS

Application Guide

Type	 Box Truck & Trailer	 Chevrolet City Express 115"	 Chevrolet Express	 Ford E-Series	 Ford Transit 130"	 Ford Transit 148"	 Ford Transit Connect	 GMC Savana
Access Pro, Inside Ladder Carrier	1050-FS P. 238	1050-M P. 239	1050-FS P. 241	1050-FS P. 243	1050-FS P. 246	1050-FS P. 246	1050-M P. 247	1050-FS P. 249
Cargo rack		1505-NS P. 238	1505-GS P. 240 1505-GS3 P. 240	1505-FE P. 241 1505-FE3 P. 242	1505-FTR P. 244 1505-FTR3 P. 244	1505-FTL P. 244 1505-FTL3 P. 244	1505-TC P. 246	1505-GS P. 248 1505-GS3 P. 248
Combination ladder rack		1525-NS P. 239 1525-NSX	1525-FS P. 240 1525-FS3 P. 241	1525-FS P. 242 1525-FS3 P. 242	1525-FTR P. 245 1525-FTR3 P. 245	1525-FTL P. 245 1525-FTL3 P. 245	1525-TC P. 247 1525-TCX P. 247	1525-FS P. 248 1525-FS3 P. 249
Double clamp ladder rack		1530-NS P. 239 1530-NSX P. 239	1530-FS P. 241 1530-FS3 P. 241	1530-FS P. 243 1530-FS3 P. 243	1530-FTR P. 245 1530-FTR3 P. 245	1530-FTL P. 245 1530-FTL3 P. 245	1530-TC P. 247 1530-TCX P. 247	1530-FS P. 249 1530-FS3 P. 249
Driver Side Retrofit kit					15-1815 P. 244	15-1815 P. 244		
Ladder rack accessory		1127 P. 239	1127 P. 241	1127 P. 243	1127 P. 246	1127 P. 246	1127 P. 247	1127 P. 249
Max Rack, Double side ladder rack					1830-FTR P. 245	1830-FTL P. 245		
Max Rack, Single side ladder rack					1820-FTR P. 245	1820-FTL P. 245		
Passenger Side Retrofit kit					15-1810 P. 243	15-1810 P. 243		
Single clamp ladder rack		1520-NS P. 238	1520-FS P. 240	1520-FS P. 242	1520-FTR P. 244	1520-FTL P. 244	1520-TC P. 246	1520-FS P. 248
Standard ladder rack		1510-NS P. 238	1510-FS P. 240 1510-FS3 P. 240	1510-FS P. 242 1510-FS3 P. 242	1510-FTR P. 244 1510-FTR3 P. 244	1510-FTL P. 244 1510-FTL3 P. 244	1510-TC P. 246	1510-FS P. 248 1510-FS3 P. 248
Third bar crossbow kit for Max Rack					15-1805 P. 243	15-1805 P. 243		

LADDER RACKS

										
Mercedes-Benz Metris 126"	Mercedes-Benz Sprinter	Nissan NV 146" Low Roof	Nissan NV 146" High Roof	Nissan NV200 115"	Ram C/V 121"	Ram ProMaster 118"	Ram ProMaster 136"	Ram ProMaster 159"	Ram ProMaster 159" Ext	Ram ProMaster City 122"
	1050-FS P. 253	1050-FS P. 255	1050-FS P. 255	1050-M P. 257	1050-M P. 258	1050-FS P. 261	1050-FS P. 261	1050-FS P. 261	1050-FS P. 261	1050-M P. 263
1505-MM P. 249	1505-DH P. 251 1505-DH3 P. 251	1505-NL P. 254 1505-NL3 P. 254	1505-NH P. 254 1505-NH3 P. 254	1505-NS P. 256	1505-M P. 257	1505-PH P. 259 1505-PH3 P. 259	1505-PH P. 259 1505-PH3 P. 259	1505-PH P. 259 1505-PH3 P. 259	1505-PH P. 259 1505-PH3 P. 259	1505-PC P. 262
1525-MM P. 250	1525-DH P. 252 1525-DH3 P. 252	1525-NL P. 254 1525-NL3 P. 255		1525-NS P. 256 1525-NSX P. 256	1525-M P. 258	1525-PHS P. 260 1525-PH3S P. 260	1525-PHM P. 260 1525-PH3M P. 260	1525-PHL P. 260 1525-PH3L P. 260	1525-PHX P. 260 1525-PH3X P. 260	1525-PC P. 262 1525-PCX P. 262
1530-MM P. 250	1530-DH P. 252 1530-DH3 P. 252	1530-NL P. 255 1530-NL3 P. 255		1530-NS P. 257 1530-NSX P. 257	1530-M P. 258	1530-PHS P. 260 1530-PH3S P. 261	1530-PHM P. 260 1530-PH3M P. 261	1530-PHL P. 260 1530-PH3L P. 261	1530-PHX P. 260 1530-PH3X P. 260	1530-PC P. 262 1530-PCX P. 263
	15-1815 P. 251	15-1815 P. 253	15-1815 P. 253			15-1815 P. 259	15-1815 P. 259	15-1815 P. 259	15-1815 P. 259	
1127 P. 250	1127 P. 253	1127 P. 256	1127 P. 256	1127 P. 257	1127 P. 258	1127 P. 261	1127 P. 261	1127 P. 261	1127 P. 261	1127 P. 263
	1830-DH P. 253		1830-NH P. 255			1830-PHS P. 261	1830-PHM P. 261	1830-PHL P. 261	1830-PHX P. 261	
	1820-DH P. 252		1820-NH P. 255			1820-PHS P. 261	1820-PHM P. 261	1820-PHL P. 261	1820-PHX P. 261	
	15-1810 P. 251	15-1810 P. 253	15-1810 P. 253			15-1810 P. 259	15-1810 P. 259	15-1810 P. 259	15-1810 P. 259	
1520-MM P. 250	1520-DH P. 252	1520-NL P. 254		1520-NS P. 256	1520-M P. 258	1520-PHS P. 260	1520-PHM P. 260	1520-PHL P. 260	1520-PHX P. 261	1520-PC P. 262
1510-MM P. 250	1510-DH P. 251 1510-DH3 P. 251	1510-NL P. 254 1510-NL3 P. 254	1510-NH P. 254 1510-NH3 P. 254	1510-NS P. 256	1510-M P. 257	1510-PH P. 259 1510-PH3 P. 259	1510-PH P. 259 1510-PH3 P. 259	1510-PH P. 259 1510-PH3 P. 259	1510-PH P. 259 1510-PH3 P. 259	1510-PC P. 262
	15-1805 P. 250	15-1805 P. 253	15-1805 P. 253			15-1805 P. 258	15-1805 P. 258	15-1805 P. 258	15-1805 P. 258	

The weight capacity varies according to each vehicle's capabilities.
Please consult your vehicle's manual for weight capacity.

LADDER RACKS



BOX TRUCK & TRAILER



Box Truck & Trailer
Access Pro, Inside Ladder Carrier

Aluminum

1050-FS	10+, 14+	Standard	96" W	9 lbs			1 hr



CHEVROLET CITY EXPRESS



Chevrolet City Express
Cargo rack

Aluminum

1505-NS	115"	Standard	54" W	480 lbs	23 lbs		0.8 hr



Chevrolet City Express
Standard ladder rack

Aluminum

1510-NS	115"	Standard	54" W	400 lbs	24 lbs		0.9 hr



Chevrolet City Express
Single clamp ladder rack

Aluminum

1520-NS	115"	Standard	54" W	400 lbs	32 lbs	24 ft	1.2 hrs

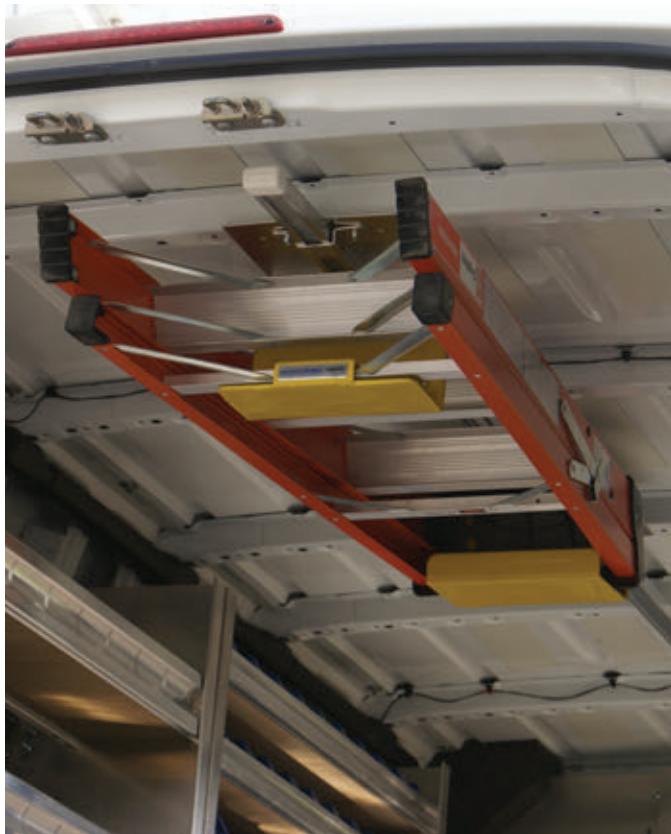

LADDER RACKS



Chevrolet City Express
Combination ladder rack

Aluminum

1525-NS	115"	Standard	54" W	400 lbs	47 lbs	24 ft	1.7 hrs



Chevrolet City Express
Combination ladder rack

Aluminum

1525-NSX	115"	Standard	54" W	450 lbs	52 lbs	28 ft	2.1 hrs



Chevrolet City Express
Double clamp ladder rack

Aluminum

1530-NS	115"	Standard	54" W	400 lbs	40 lbs	24 ft	1.7 hrs



Chevrolet City Express
Double clamp ladder rack

Aluminum

1530-NSX	115"	Standard	54" W	450 lbs	54 lbs	28 ft	2 hrs



Chevrolet City Express
Access Pro, Inside Ladder Carrier

Aluminum

1050-M	115"	Standard	60" W		9 lbs		1 hr



Chevrolet City Express
Ladder rack accessory

Aluminum

1127	115"	Standard	23" W		18 lbs		0.5 hr

LADDER RACKS



CHEVROLET EXPRESS



Chevrolet Express
Cargo rack

Aluminum

1505-GS	135", 155"	Standard	68" W	480 lbs	23 lbs		0.8 hr



Chevrolet Express
Cargo rack

Aluminum

1505-GS3	135", 155"	Standard	68" W	720 lbs	35 lbs		1.2 hrs



Chevrolet Express
Standard ladder rack

Aluminum

1510-FS	135", 155"	Standard	68" W	400 lbs	21 lbs		0.9 hr



Chevrolet Express
Standard ladder rack

Aluminum

1510-FS3	135", 155"	Standard	68" W	600 lbs	29 lbs		1.3 hrs



Chevrolet Express
Single clamp ladder rack

Aluminum

1520-FS	135", 155"	Standard	68" W	400 lbs	28 lbs	32 ft	1.2 hrs



Chevrolet Express
Combination ladder rack

Aluminum

1525-FS	135", 155"	Standard	68" W	400 lbs	49 lbs	32 ft	1.7 hrs

LADDER RACKS



Chevrolet Express
Combination ladder rack

Aluminum



1525-FS3	135", 155"	Standard	68" W	600 lbs	57 lbs	32 ft	2.1 hrs
-----------------	------------	----------	-------	---------	--------	-------	---------



Chevrolet Express
Double clamp ladder rack

Aluminum



1530-FS	135", 155"	Standard	68" W	400 lbs	50 lbs	32 ft	1.7 hrs
----------------	------------	----------	-------	---------	--------	-------	---------



Chevrolet Express
Double clamp ladder rack

Aluminum



1530-FS3	135", 155"	Standard	68" W	600 lbs	58 lbs	32 ft	2.1 hrs
-----------------	------------	----------	-------	---------	--------	-------	---------



Chevrolet Express
Access Pro, Inside Ladder Carrier

Aluminum



1050-FS	135", 155"	Standard	96" W	9 lbs			1 hr
----------------	------------	----------	-------	-------	--	--	------



Chevrolet Express
Ladder rack accessory

Aluminum



1127	135", 155"	Standard	23" W	18 lbs			0.5 hr
-------------	------------	----------	-------	--------	--	--	--------



**FORD
E-SERIES**

LADDER RACKS



Ford E-Series
Cargo rack

Aluminum



1505-FE	138", 138" Ext	Standard	68" W	480 lbs	22 lbs		0.8 hr
----------------	-------------------	----------	-------	---------	--------	--	--------

LEGEND

Wheelbase Roof Height Dimensions Weight Capacity Weight Estimated Install Time

LADDER RACKS



Ford E-Series
Cargo rack

Aluminum

1505-FE3	138", 138" Ext	Standard	68" W	720 lbs	32 lbs		1.2 hrs



Ford E-Series
Single clamp ladder rack

Aluminum

1520-FS	138", 138" Ext	Standard	68" W	400 lbs	28 lbs	32 ft	1.2 hrs



Ford E-Series
Standard ladder rack

Aluminum

1510-FS	138", 138" Ext	Standard	68" W	400 lbs	21 lbs		0.9 hr



Ford E-Series
Combination ladder rack

Aluminum

1525-FS	138", 138" Ext	Standard	68" W	400 lbs	49 lbs	32 ft	1.7 hrs



Ford E-Series
Standard ladder rack

Aluminum

1510-FS3	138", 138" Ext	Standard	68" W	600 lbs	29 lbs		1.3 hrs



Ford E-Series
Combination ladder rack

Aluminum

1525-FS3	138", 138" Ext	Standard	68" W	600 lbs	57 lbs	32 ft	2.1 hrs

LADDER RACKS



Ford E-Series
Double clamp ladder rack

Aluminum

1530-FS	138", 138" Ext	Standard	68" W	400 lbs	50 lbs	32 ft	1.7 hrs



Ford E-Series
Double clamp ladder rack

Aluminum

1530-FS3	138", 138" Ext	Standard	68" W	600 lbs	58 lbs	32 ft	2.1 hrs



Ford E-Series
Access Pro, Inside Ladder Carrier

Aluminum

1050-FS	138", 138" Ext	Standard	96" W	9 lbs			1 hr



Ford E-Series
Ladder rack accessory

Aluminum

1127	138", 138" Ext	Standard	23" W	18 lbs			0.5 hr



**FORD
TRANSIT**



Ford Transit
Third bar crossbow kit for Max Rack

Aluminum

15-1805	130", 148", 148" Ext	Low, Medium, High	72" W	200 lbs	10 lbs		0.5 hr



Ford Transit
Passenger Side Retrofit kit

Aluminum

15-1810	130", 148", 148" Ext	Low, Medium, High			57 lbs		1 hr

LADDER RACKS



Ford Transit
Driver Side Retrofit kit

Aluminum

15-1815	130", 148", 148" Ext	Low, Medium, High				57 lbs	1 hr



Ford Transit
Cargo rack

Aluminum

1505-FTR	130"	Low, Medium	72" W	480 lbs	18 lbs		0.8 hr
1505-FTL	148", 148" Ext	Low, Medium, High	72" W	480 lbs	18 lbs		0.8 hr



Ford Transit
Cargo rack

Aluminum

1505-FTR3	130"	Low, Medium	72" W	720 lbs	27 lbs		1.2 hrs
1505-FTL3	148", 148" Ext	Low, Medium, High	72" W	720 lbs	27 lbs		1.3 hrs



Ford Transit
Standard ladder rack

Aluminum

1510-FTR	130"	Low, Medium	72" W	400 lbs	21 lbs		0.8 hr
1510-FTL	148", 148" Ext	Low, Medium, High	72" W	400 lbs	21 lbs		0.8 hr



Ford Transit
Standard ladder rack

Aluminum

1510-FTR3	130"	Low, Medium	72" W		60 lbs		1.2 hrs
1510-FTL3	148", 148" Ext	Low, Medium, High	72" W		52 lbs		1.2 hrs



Ford Transit
Single clamp ladder rack

Aluminum

1520-FTR	130"	Low, Medium	72" W	400 lbs	34 lbs	32 ft	1.2 hrs
1520-FTL	148", 148" Ext	Low, Medium, High	72" W	400 lbs	34 lbs	32 ft	1.2 hrs



Ford Transit
Combination ladder rack

Aluminum							
1525-FTR	130"	Low, Medium	72" W	400 lbs	49 lbs	32 ft	1.7 hrs
1525-FTL	148", 148" Ext	Low, Medium, High	72" W	400 lbs	49 lbs	32 ft	1.7 hrs



Ford Transit
Combination ladder rack

Aluminum							
1525-FTR3	130"	Low, Medium	72" W	600 lbs	57 lbs	32 ft	2.1 hrs
1525-FTL3	148", 148" Ext	Low, Medium, High	72" W	600 lbs	57 lbs	32 ft	2.1 hrs



Ford Transit
Double clamp ladder rack

Aluminum							
1530-FTR	130"	Low, Medium	72" W	400 lbs	50 lbs	32 ft	1.7 hrs
1530-FTL	148", 148" Ext	Low, Medium, High	72" W	400 lbs	50 lbs	32 ft	1.7 hrs



Ford Transit
Double clamp ladder rack

Aluminum							
1530-FTR3	130"	Low, Medium	72" W	600 lbs	58 lbs	32 ft	2.1 hrs
1530-FTL3	148", 148" Ext	Low, Medium, High	72" W	600 lbs	58 lbs	32 ft	2.1 hrs



Ford Transit
Max Rack, Single side ladder rack

Aluminum							
1820-FTR	130"	Low, Medium	72" W	100 lbs	82 lbs	24 ft	2 hrs
1820-FTL	148", 148" Ext	Low, Medium, High	72" W	100 lbs	82 lbs	32 ft	2 hrs



Ford Transit
Max Rack, Double side ladder rack

Aluminum							
1830-FTR	130"	Low, Medium	72" W	200 lbs	139 lbs	24 ft	3 hrs
1830-FTL	148", 148" Ext	Low, Medium, High	72" W	200 lbs	139 lbs	32 ft	3 hrs

LADDER RACKS



Ford Transit
Access Pro, Inside Ladder Carrier

Aluminum

1050-FS	130", 148", 148" Ext	Low, Medium, High	96" W	9 lbs		1 hr	



Ford Transit
Ladder rack accessory

Aluminum

1127	130", 148", 148" Ext	Low, Medium, High	23" W	18 lbs		0.5 hr	



FORD TRANSIT CONNECT



Ford Transit Connect
Cargo rack

Aluminum

1505-TC	105", 120.5"	Standard	60" W	480 lbs	18 lbs		0.8 hr



Ford Transit Connect
Standard ladder rack

Aluminum

1510-TC	105", 120.5"	Standard	60" W	400 lbs	18 lbs		0.9 hr



Ford Transit Connect
Single clamp ladder rack

Aluminum

1520-TC	105", 120.5"	Standard	60" W	400 lbs	28 lbs	24 ft	1.2 hrs



Ford Transit Connect
Combination ladder rack

Aluminum



1525-TC	105", 120.5"	Standard	60" W	400 lbs	47 lbs	24 ft	1.7 hrs
----------------	--------------	----------	-------	---------	--------	-------	---------



Ford Transit Connect
Double clamp ladder rack

Aluminum



1530-TCX	105", 120.5"	Standard	60" W	400 lbs	36 lbs	28 ft	1.7 hrs
-----------------	--------------	----------	-------	---------	--------	-------	---------



Ford Transit Connect
Combination ladder rack

Aluminum



1525-TCX	105", 120.5"	Standard	60" W	400 lbs	52 lbs	28 ft	1.7 hrs
-----------------	--------------	----------	-------	---------	--------	-------	---------



Ford Transit Connect
Access Pro, Inside Ladder Carrier

Aluminum



1050-M	120.5"	Standard	60" W	9 lbs			1 hr
---------------	--------	----------	-------	-------	--	--	------



Ford Transit Connect
Double clamp ladder rack

Aluminum



1530-TC	105", 120.5"	Standard	60" W	400 lbs	36 lbs	24 ft	1.7 hrs
----------------	--------------	----------	-------	---------	--------	-------	---------



Ford Transit Connect
Ladder rack accessory

Aluminum



1127	105", 120.5"	Standard	23" W	18 lbs			0.5 hr
-------------	--------------	----------	-------	--------	--	--	--------

LADDER RACKS



**GMC
SAVANA**



GMC Savana
Cargo rack

Aluminum

1505-GS	135", 155"	Standard	68" W	480 lbs	23 lbs		0.8 hr



GMC Savana
Cargo rack

Aluminum

1505-GS3	135", 155"	Standard	68" W	720 lbs	35 lbs		1.2 hrs



GMC Savana
Standard ladder rack

Aluminum

1510-FS	135", 155"	Standard	68" W	400 lbs	21 lbs		0.9 hr



GMC Savana
Standard ladder rack

Aluminum

1510-FS3	135", 155"	Standard	68" W	600 lbs	29 lbs		1.3 hrs



GMC Savana
Single clamp ladder rack

Aluminum

1520-FS	135", 155"	Standard	68" W	400 lbs	28 lbs	32 ft	1.2 hrs



GMC Savana
Combination ladder rack

Aluminum

1525-FS	135", 155"	Standard	68" W	400 lbs	49 lbs	32 ft	1.7 hrs

LADDER RACKS



GMC Savana
Combination ladder rack

Aluminum



1525-FS3	135", 155"	Standard	68" W	600 lbs	57 lbs	32 ft	2.1 hrs
-----------------	------------	----------	-------	---------	--------	-------	---------



GMC Savana
Double clamp ladder rack

Aluminum



1530-FS	135", 155"	Standard	68" W	400 lbs	50 lbs	32 ft	1.7 hrs
----------------	------------	----------	-------	---------	--------	-------	---------



GMC Savana
Double clamp ladder rack

Aluminum



1530-FS3	135", 155"	Standard	68" W	600 lbs	58 lbs	32 ft	2.1 hrs
-----------------	------------	----------	-------	---------	--------	-------	---------



GMC Savana
Access Pro, Inside Ladder Carrier

Aluminum



1050-FS	135", 155"	Standard	96" W	9 lbs			1 hr
----------------	------------	----------	-------	-------	--	--	------



GMC Savana
Ladder rack accessory

Aluminum



1127	135", 155"	Standard	23" W	18 lbs			0.5 hr
-------------	------------	----------	-------	--------	--	--	--------



MERCEDES-BENZ METRIS



Mercedes-Benz Metris
Cargo rack

Aluminum



1505-MM	126"	Standard	64" W	480 lbs	33 lbs		0.8 hr
----------------	------	----------	-------	---------	--------	--	--------

LADDER RACKS



Mercedes-Benz Metris
Standard ladder rack

Aluminum

1510-MM	126"	Standard	64" W	400 lbs	33 lbs		0.9 hr



Mercedes-Benz Metris
Double clamp ladder rack

Aluminum

1530-MM	126"	Standard	64" W	400 lbs	56 lbs	28 ft	1.7 hrs



Mercedes-Benz Metris
Single clamp ladder rack

Aluminum

1520-MM	126"	Standard	64" W	400 lbs	43 lbs	28 ft	1.2 hrs



Mercedes-Benz Metris
Ladder rack accessory

Aluminum

1127	126"	Standard	23" W		18 lbs		0.5 hr



**MERCEDES-BENZ
SPRINTER**



Mercedes-Benz Metris
Combination ladder rack

Aluminum

1525-MM	126"	Standard	64" W	400 lbs	64 lbs	28 ft	1.7 hrs



Mercedes-Benz Sprinter
Third bar crossbow kit for Max Rack

Aluminum

15-1805	144", 170", 170" Ext	Low, High	72" W	200 lbs	10 lbs		0.5 hr

LADDER RACKS



Mercedes-Benz Sprinter
Passenger Side Retrofit kit

Aluminum

15-1810	144", 170", 170" Ext	Low, High		57 lbs		1 hr



Mercedes-Benz Sprinter
Driver Side Retrofit kit

Aluminum

15-1815	144", 170", 170" Ext	Low, High		57 lbs		1 hr



Mercedes-Benz Sprinter
Cargo rack

Aluminum

1505-DH	144", 170", 170" Ext	High	68" W	480 lbs	20 lbs	0.8 hr



Mercedes-Benz Sprinter
Cargo rack

Aluminum

1505-DH3	144", 170", 170" Ext	High	68" W	720 lbs	30 lbs	1.2 hrs



Mercedes-Benz Sprinter
Standard ladder rack

Aluminum

1510-DH	144", 170", 170" Ext	High	68" W	400 lbs	21 lbs	0.9 hr



Mercedes-Benz Sprinter
Standard ladder rack

Aluminum

1510-DH3	144", 170", 170" Ext	High	68" W	600 lbs	30 lbs	1.3 hrs

LEGEND

Wheelbase Roof Height Dimensions Weight Capacity Weight Estimated Install Time

LADDER RACKS



Mercedes-Benz Sprinter
Single clamp ladder rack

Aluminum

1520-DH	144", 170", 170" Ext	High	68" W	400 lbs	30 lbs	32 ft	1.2 hrs



Mercedes-Benz Sprinter
Double clamp ladder rack

Aluminum

1530-DH	144", 170", 170" Ext	High	68" W	400 lbs	49 lbs	32 ft	1.7 hrs



Mercedes-Benz Sprinter
Combination ladder rack

Aluminum

1525-DH	144", 170", 170" Ext	High	68" W	400 lbs	48 lbs	32 ft	1.7 hrs



Mercedes-Benz Sprinter
Double clamp ladder rack

Aluminum

1530-DH3	144", 170", 170" Ext	High	68" W	600 lbs	58 lbs	32 ft	2.1 hrs



Mercedes-Benz Sprinter
Combination ladder rack

Aluminum

1525-DH3	144", 170", 170" Ext	High	68" W	600 lbs	57 lbs	32 ft	2.1 hrs



Mercedes-Benz Sprinter
Max Rack, Single side ladder rack

Aluminum

1820-DH	144", 170", 170" Ext	High	72" W	82 lbs	32 ft	2 hrs	

LADDER RACKS



Mercedes-Benz Sprinter
Max Rack, Double side ladder rack

Aluminum

1830-DH	144", 170", 170" Ext	High	72" W	139 lbs	32 ft	3 hrs	



Mercedes-Benz Sprinter
Access Pro, Inside Ladder Carrier

Aluminum

1050-FS	144", 170", 170" Ext	Low, High	96" W	9 lbs		1 hr	



Mercedes-Benz Sprinter
Ladder rack accessory

Aluminum

1127	144", 170", 170" Ext	Low, High	23" W	18 lbs		0.5 hr	



**NISSAN
NV**



Nissan NV
Third bar crossbow kit for Max Rack

Aluminum

15-1805	146"	Low, High	72" W	200 lbs	10 lbs		0.5 hr



Nissan NV
Passenger Side Retrofit kit

Aluminum

15-1810	146"	Low, High		57 lbs			1.6 hrs



Nissan NV
Driver Side Retrofit kit

Aluminum

15-1815	146"	Low, High		57 lbs			1.6 hrs

LADDER RACKS



Nissan NV
Cargo rack

Aluminum							
1505-NL	146"	Low	72" W	480 lbs	33 lbs		0.8 hr
1505-NH	146"	High	72" W	480 lbs	28 lbs		0.8 hr



Nissan NV
Cargo rack

Aluminum							
1505-NL3	146"	Low	72" W	720 lbs	43 lbs		1.2 hrs
1505-NH3	146"	High	72" W	720 lbs	37 lbs		1.2 hrs



Nissan NV
Standard ladder rack

Aluminum							
1510-NL	146"	Low	72" W	400 lbs	33 lbs		0.9 hr
1510-NH	146"	High	72" W	400 lbs	28 lbs		0.9 hr



Nissan NV
Standard ladder rack

Aluminum							
1510-NL3	146"	Low	72" W	600 lbs	43 lbs		1.3 hrs
1510-NH3	146"	High	72" W	600 lbs	39 lbs		1.3 hrs



Nissan NV
Single clamp ladder rack

Aluminum							
1520-NL	146"	Low	72" W	400 lbs	42 lbs	32 ft	1.2 hrs



Nissan NV
Combination ladder rack

Aluminum							
1525-NL	146"	Low	72" W	400 lbs	61 lbs	32 ft	1.7 hrs

LADDER RACKS



Nissan NV
Combination ladder rack

Aluminum

1525-NL3	146"	Low	72" W	600 lbs	71 lbs	32 ft	2.1 hrs



Nissan NV
Max Rack, Single side ladder rack

Aluminum

1820-NH	146"	High	72" W	82 lbs	24 ft	3.2 hrs	



Nissan NV
Double clamp ladder rack

Aluminum

1530-NL	146"	Low	72" W	400 lbs	53 lbs	32 ft	1.7 hrs



Nissan NV
Max Rack, Double side ladder rack

Aluminum

1830-NH	146"	High	72" W	139 lbs	24 ft	4.4 hrs	



Nissan NV
Double clamp ladder rack

Aluminum

1530-NL3	146"	Low	72" W	600 lbs	63 lbs	32 ft	2.1 hrs



Nissan NV
Access Pro, Inside Ladder Carrier

Aluminum

1050-FS	146"	Low, High	96" W	9 lbs	1 hr		

LEGEND

Wheelbase Roof Height Dimensions Weight Capacity Weight Estimated Install Time

LADDER RACKS



Nissan NV
Ladder rack accessory

Aluminum

1127	146"	Low, High	23" W	18 lbs			0.5 hr



Nissan NV200
Single clamp ladder rack

Aluminum

1520-NS	115"	Standard	54" W	400 lbs	32 lbs	24 ft	1.2 hrs



**NISSAN
NV200**



Nissan NV200
Cargo rack

Aluminum

1505-NS	115"	Standard	54" W	480 lbs	23 lbs		0.8 hr



Nissan NV200
Combination ladder rack

Aluminum

1525-NS	115"	Standard	54" W	400 lbs	47 lbs	24 ft	1.7 hrs



Nissan NV200
Standard ladder rack

Aluminum

1510-NS	115"	Standard	54" W	400 lbs	24 lbs		0.9 hr



Nissan NV200
Combination ladder rack

Aluminum

1525-NSX	115"	Standard	54" W	450 lbs	52 lbs	28 ft	2.1 hrs

LADDER RACKS



Nissan NV200
Double clamp ladder rack

Aluminum

1530-NS	115"	Standard	54" W	400 lbs	40 lbs	24 ft	1.7 hrs



Nissan NV200
Ladder rack accessory

Aluminum

1127	115"	Standard	23" W	18 lbs			0.5 hr



Nissan NV200
Double clamp ladder rack

Aluminum

1530-NSX	115"	Standard	54" W	450 lbs	54 lbs	28 ft	2 hrs



**RAM
C/V**



Ram C/V
Cargo rack

Aluminum

1505-M	121"	Standard	60" W	480 lbs	18 lbs		0.8 hr



Nissan NV200
Access Pro, Inside Ladder Carrier

Aluminum

1050-M	115"	Standard	60" W	9 lbs			1 hr



Ram C/V
Standard ladder rack

Aluminum

1510-M	121"	Standard	60" W	400 lbs	19 lbs		0.9 hr

LADDER RACKS



Ram C/V
Single clamp ladder rack

Aluminum

1520-M	121"	Standard	60" W	400 lbs	29 lbs	24 ft	1.2 hrs



Ram C/V
Combination ladder rack

Aluminum

1525-M	121"	Standard	60" W	400 lbs	42 lbs	24 ft	1.7 hrs



Ram C/V
Double clamp ladder rack

Aluminum

1530-M	121"	Standard	60" W	400 lbs	43 lbs	24 ft	1.7 hrs



Ram C/V
Access Pro, Inside Ladder Carrier

Aluminum

1050-M	121"	Standard	60" W		9 lbs		1 hr



Ram C/V
Ladder rack accessory

Aluminum

1127	121"	Standard	23" W		18 lbs		0.5 hr



RAM
PROMASTER



Ram ProMaster
Third bar crossbow kit for Max Rack

Aluminum

15-1805	118", 136", 159", 159" Ext	Standard, High	72" W	200 lbs	10 lbs		0.5 hr

LADDER RACKS

LADDER RACKS



Ram ProMaster
Passenger Side Retrofit kit

Aluminum

15-1810	118", 136", 159", 159" Ext	Standard, High		57 lbs		1.6 hrs



Ram ProMaster
Cargo rack

Aluminum

1505-PH3	118", 136", 159", 159" Ext	Standard, High	72" W	720 lbs	27 lbs	1.2 hrs



Ram ProMaster
Driver Side Retrofit kit

Aluminum

15-1815	118", 136", 159", 159" Ext	Standard, High		57 lbs		1.6 hrs



Ram ProMaster
Standard ladder rack

Aluminum

1510-PH	118", 136", 159", 159" Ext	Standard, High	72" W	400 lbs	25 lbs	0.9 hr



Ram ProMaster
Cargo rack

Aluminum

1505-PH	118", 136", 159", 159" Ext	Standard, High	72" W	480 lbs	18 lbs	0.8 hr



Ram ProMaster
Standard ladder rack

Aluminum

1510-PH3	118", 136", 159", 159" Ext	Standard, High	72" W		27 lbs	1.2 hrs

LADDER RACKS

LEGEND

Wheelbase Roof Height Dimensions Weight Capacity Weight Estimated Install Time

LADDER RACKS



Ram ProMaster
Single clamp ladder rack

Aluminum							
1520-PHS	118"	Standard	72" W	400 lbs	46 lbs	28 ft	1.2 hrs
1520-PHM	136"	Standard, High	72" W	400 lbs	48 lbs	32 ft	1.2 hrs
1520-PHL	159"	High	72" W	400 lbs	43 lbs	32 ft	1.2 hrs
1520-PHX	159" Ext	High	72" W	400 lbs	43 lbs	32 ft	1.2 hrs



Ram ProMaster
Combination ladder rack

Aluminum							
1525-PHS	118"	Standard	72" W	400 lbs	69 lbs	28 ft	1.7 hrs
1525-PHM	136"	Standard, High	72" W	400 lbs	70 lbs	32 ft	1.7 hrs
1525-PHL	159"	High	72" W	400 lbs	66 lbs	32 ft	1.7 hrs
1525-PHX	159" Ext	High	72" W	400 lbs	66 lbs	32 ft	1.7 hrs



Ram ProMaster
Combination ladder rack

Aluminum							
1525-PH3S	118"	Standard	72" W	600 lbs	52 lbs	28 ft	2.1 hrs
1525-PH3M	136"	Standard, High	72" W	600 lbs	52 lbs	32 ft	2.1 hrs
1525-PH3L	159"	High	72" W	600 lbs	52 lbs	32 ft	2.1 hrs
1525-PH3X	159" Ext	High	72" W	600 lbs	52 lbs	32 ft	2.1 hrs



Ram ProMaster
Double clamp ladder rack

Aluminum							
1530-PHS	118"	Standard	72" W	400 lbs	60 lbs	28 ft	1.7 hrs
1530-PHM	136"	Standard, High	72" W	400 lbs	61 lbs	32 ft	1.7 hrs
1530-PHL	159"	High	72" W	400 lbs	57 lbs	32 ft	1.7 hrs
1530-PHX	159" Ext	High	72" W	400 lbs	57 lbs	32 ft	1.7 hrs

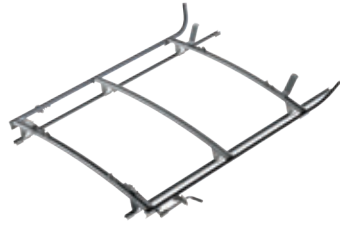

Ram ProMaster
Double clamp ladder rack

Aluminum

1530-PH3S	118"	Standard	72" W	600 lbs	45 lbs	28 ft	2.1 hrs
1530-PH3M	136"	Standard, High	72" W	600 lbs	45 lbs	32 ft	2.1 hrs
1530-PH3L	159"	High	72" W	600 lbs	45 lbs	32 ft	2.1 hrs
1530-PH3X	159" Ext	High	72" W	600 lbs	45 lbs	32 ft	2.1 hrs



Ram ProMaster
Max Rack, Single side ladder rack

Aluminum

1820-PHS	118"	Standard	72" W	100 lbs	86 lbs	28 ft	3.2 hrs
1820-PHM	136"	Standard, High	72" W	100 lbs	89 lbs	32 ft	3.2 hrs
1820-PHL	159"	High	72" W	100 lbs	90 lbs	32 ft	3.2 hrs
1820-PHX	159" Ext	High	72" W	100 lbs	94 lbs	32 ft	3.2 hrs



Ram ProMaster
Max Rack, Double side ladder rack

Aluminum

1830-PHS	118"	Standard	72" W	200 lbs	139 lbs	28 ft	4.4 hrs
1830-PHM	136"	Standard, High	72" W	200 lbs	141 lbs	32 ft	4.4 hrs
1830-PHL	159"	High	72" W	200 lbs	143 lbs	32 ft	4.4 hrs
1830-PHX	159" Ext	High	72" W	200 lbs	147 lbs	32 ft	4.4 hrs



Ram ProMaster
Access Pro, Inside Ladder Carrier

Aluminum

1050-FS	118", 136", 159", 159" Ext	Standard, High	96" W	9 lbs			1 hr



Ram ProMaster
Ladder rack accessory

Aluminum

1127	118", 136", 159", 159" Ext	Standard, High	23" W	18 lbs			0.5 hr

LADDER RACKS



RAM PROMASTER CITY



Ram ProMaster City
Cargo rack

Aluminum

1505-PC	122"	Standard	60" W	480 lbs	28 lbs		0.8 hr



Ram ProMaster City
Standard ladder rack

Aluminum

1510-PC	122"	Standard	60" W	400 lbs	28 lbs		0.9 hr



Ram ProMaster City
Single clamp ladder rack

Aluminum

1520-PC	122"	Standard	60" W	400 lbs	40 lbs	24 ft	1.2 hrs



Ram ProMaster City
Combination ladder rack

Aluminum

1525-PC	122"	Standard	60" W	400 lbs	60 lbs	24 ft	1.7 hrs



Ram ProMaster City
Combination ladder rack

Aluminum

1525-PCX	122"	Standard	60" W	400 lbs	69 lbs	28 ft	2.1 hrs



Ram ProMaster City
Double clamp ladder rack

Aluminum

1530-PC	122"	Standard	60" W	400 lbs	52 lbs	24 ft	1.7 hrs

LADDER RACKS



Ram ProMaster City
Double clamp ladder rack

Aluminum

1530-PCX	122"	Standard	60" W	450 lbs	61 lbs	28 ft	2 hrs



Ram ProMaster City
Access Pro, Inside Ladder Carrier

Aluminum

1050-M	122"	Standard	60" W	9 lbs			1 hr



Ram ProMaster City
Ladder rack accessory

Aluminum

1127	122"	Standard	23" W	18 lbs			0.5 hr

RANGER DESIGN MAX RACK



LADDER RACKS



MAX RACK

DESIGNED FOR HIGH ROOF VANS

SAFE & EASY TO USE

50" OF TRAVEL

The Max Rack drops lower in one movement than any other rack in the industry.

- Max Rack
- Competitor's rack

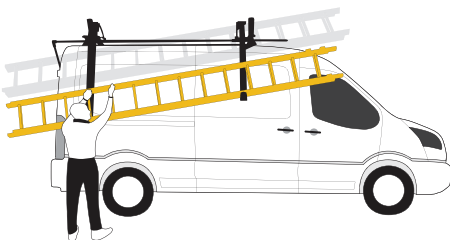

- › Two pressurized gas shocks support the weight of the ladder, assist in lifting and lowering the ladder and also hold it in the closed position.
- › Max Rack is adjustable to fit most ladders.

LOW PROFILE

There is less chances of the Max Rack hitting low hanging objects.



- › Ladders only touch composite materials, reducing ladder wear.
- › Comes down in one single motion.

EXTREME WEATHER PROOF

The Max Rack was put through extreme weather testing.



CYCLE TESTING

The Max Rack completed over 4300 cycles, which represents approximately 15 years of normal use.

MAX RACK IS FAST AND EASY TO OPERATE

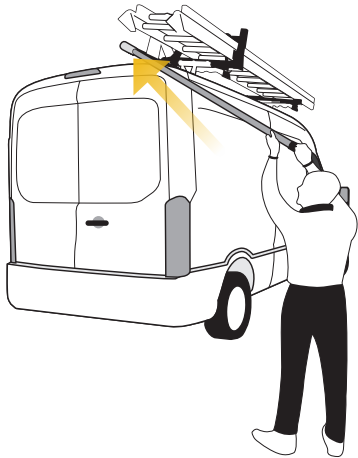

1

STEP ONE

With both hands, insert the control arm into the Max Rack.

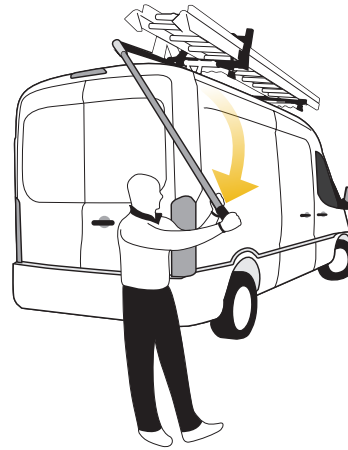

2

STEP TWO

Pull the control arm down towards you.

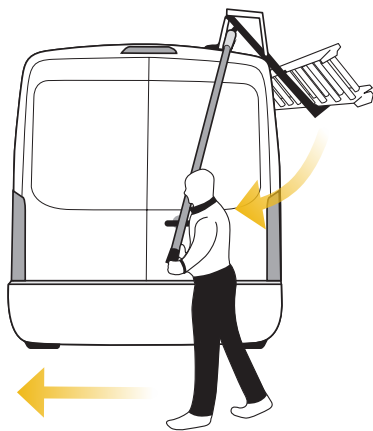

3

STEP THREE

Turn around. Push the control arm forward.

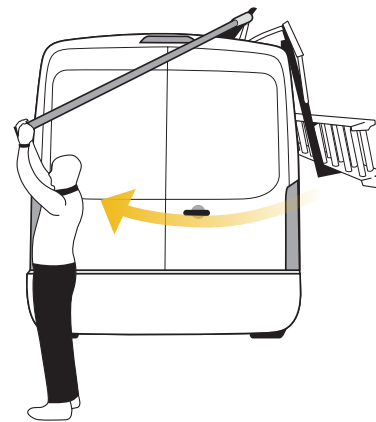

4

STEP FOUR

Continue to push the control arm until the Max Rack has finished its descent.

RACK CAPACITY



STEP LADDERS
8' AND 10'

Fits all Max Racks
Must have the 3rd bar crossbow on the Max Rack



The Max Rack can carry extension ladders for the standard and high roof vans, with a third bar option #15-1805.

Please see each vehicle specific description for height.

The weight capacity per single Max Rack is 100lbs.

INSTALL KITS



Product #	Transit Regular Wheelbase, Low Roof	Transit Long Wheelbase, Low Roof	Transit Regular Wheelbase, Medium Roof	Transit Long Wheelbase Medium/High Roof	Transit Long Wheelbase Extended High Roof
5025, 5020, X02-A	6473 (5020, X02-A) 6474 (5025)	6473 (5020, X02-A) 6474 (5025)	6473 (5020, X02-A) 6474 (5025)	6473 (5020, X02-A) 6474 (5025)	6473 (5020, X02-A) 6474 (5025)
All Shelving, Lockers and Drawers Driver side	6430	6432	6434	6436	6438
All Shelving Passenger side	6431	6433	6435	6437	6439
All Fold-Away Shelving Driver side	84-7119	84-7121	84-7123	84-7125	84-7127
All Fold-Away Shelving Passenger side	84-7120	84-7122	84-7124	84-7126	84-7128



Product #	NV	ProMaster Short Wheel Base	ProMaster Medium Wheel Base	ProMaster Long Wheel Base	ProMaster Extended Wheel Base
5025, 5020, X02-A	-	-	-	-	-
All Shelving, Lockers and Drawers Driver side	6401	6412	6414	6416	6418
All Shelving Passenger side	6402	6413	6415	6417	6419
All Fold-Away Shelving Driver side	84-7105	84-7109	84-7111	84-7113	84-7115
All Fold-Away Shelving Passenger side	84-7106	84-7110	84-7112	84-7114	84-7116



Product #	Transit Connect Short Wheelbase	Transit Connect Long Wheelbase	ProMaster City	RAM C/V	City Express/NV200
5025, 5020, X02-A	–	6428	6428	–	–
32" Shelving Driver side	–	–	–	–	–
32" Shelving Passenger side	–	–	–	–	–
36" Shelving Driver side	6426	6424	6480	–	–
36" Shelving Passenger side	6425	6421	6480	–	–
All 56" Shelving	–	–	–	–	–
60" Shelving Driver side	–	6429	6479	–	–
60" Shelving Passenger side	–	–	6479	–	–
Axess Tray	6472	6472	6400	–	6471
Fold Away Shelving Driver side	–	84-7117	84-7130	–	84-7107
Fold Away Shelving Passenger side	–	84-7118	84-7130	–	84-7108

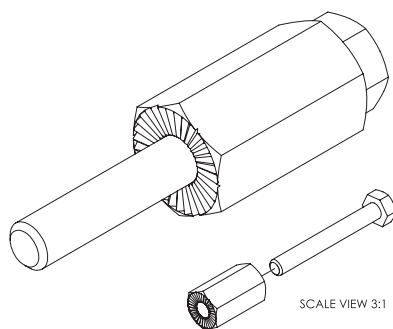

The Plus Nut/Riv-Nut tool (#6490) is available at no charge upon request.

INDEX

1050-FS 238	1505-GS 248	1520-NS. 238	1530-FTL 245	3010-NL 41
1050-FS 241	1505-GS3 240	1520-NS. 256	1530-FTL3 245	3010-NS. 28
1050-FS 243	1505-GS3 248	1520-PC. 262	1530-FTR 245	3010-NS. 43
1050-FS 246	1505-M 257	1520-PHL 260	1530-FTR3 245	3010-PC 46
1050-FS 249	1505-MM 249	1520-PHM 260	1530-M 258	3010-RP 45
1050-FS 253	1505-NH 254	1520-PHS 260	1530-MM 250	3010-TC 34
1050-FS 255	1505-NH3 254	1520-PHX 260	1530-NL 255	3015-DH 38
1050-FS 261	1505-NL 254	1520-TC 246	1530-NL3 255	3020-DH 38
1050-M 239	1505-NL3 254	1525-DH 252	1530-NS 239	3020-DL 38
1050-M 247	1505-NS 238	1525-DH3 252	1530-NS 257	3020-FTH 31
1050-M 257	1505-NS 256	1525-FS 240	1530-NSX 239	3020-FTL 31
1050-M 258	1505-PC 262	1525-FS 242	1530-NSX 257	3020-FTM 31
1050-M 263	1505-PH 259	1525-FS 248	1530-PC 262	3020-GS 29
1127 239	1505-PH3 259	1525-FS3 241	1530-PCX 263	3020-GS 36
1127 241	1505-TC 246	1525-FS3 242	1530-PH3L 261	3020-NH 42
1127 243	1510-DH 251	1525-FS3 249	1530-PH3M 261	3020-NL 42
1127 246	1510-DH3 251	1525-FTL 245	1530-PH3S 261	3020-NS 28
1127 247	1510-FS 240	1525-FTL3 245	1530-PH3X 261	3020-NS 43
1127 249	1510-FS 242	1525-FTR 245	1530-PHL 260	3020-PC 47
1127 250	1510-FS 248	1525-FTR3 245	1530-PHM 260	3020-RP 45
1127 253	1510-FS3 240	1525-M 258	1530-PHS 260	3020-TC 34
1127 256	1510-FS3 242	1525-MM 250	1530-PHX 260	3024 232
1127 257	1510-FS3 248	1525-NL 254	1530-TC 247	3025-DH 38
1127 258	1510-FTL 244	1525-NL3 255	1530-TCX 247	3044 232
1127 261	1510-FTL3 244	1525-NS. 239	1820-DH 252	3060-DH 38
1127 263	1510-FTR 244	1525-NS. 256	1820-FTL 245	3060-DL 39
1130 228	1510-FTR3 244	1525-NSX 239	1820-FTR 245	3064-DH 39
15-1805 243	1510-M 257	1525-NSX 256	1820-NH 255	3064-DL 39
15-1805 250	1510-MM 250	1525-PC 262	1820-PHL 261	3068-DH 39
15-1805 253	1510-NH 254	1525-PCX 262	1820-PHM 261	3068-DL 39
15-1805 258	1510-NH3 254	1525-PH3L 260	1820-PHS 261	3068-FTH 32
15-1810 243	1510-NL 254	1525-PH3M 260	1820-PHX 261	3068-FTM 32
15-1810 251	1510-NL3 254	1525-PH3S 260	1830-DH 253	3068-RP 45
15-1810 253	1510-NS 238	1525-PH3X 260	1830-FTL 245	3310-PC 47
15-1810 259	1510-NS 256	1525-PHL 260	1830-FTR 245	3320-FTL 32
15-1815 244	1510-PC 262	1525-PHM 260	1830-NH 255	3320-MM 37
15-1815 251	1510-PH 259	1525-PHS 260	1830-PHL 261	3320-PC 47
15-1815 253	1510-PH3 259	1525-PHX 260	1830-PHM 261	3320-TC 35
15-1815 259	1510-TC 246	1525-TC 247	1830-PHS 261	4036-3 185
1505-DH 251	1520-DH 252	1525-TCX 247	1830-PHX 261	4036-4 185
1505-DH3 251	1520-FS 240	1530-DH 252	3010-DH 37	4048-3 185
1505-FE 241	1520-FS 242	1530-DH3 252	3010-DL 38	4048-4 185
1505-FE3 242	1520-FS 248	1530-FS 241	3010-FTH 30	4060-3 185
1505-FTL 244	1520-FTL 244	1530-FS 243	3010-FTL 30	4060-4 185
1505-FTL3 244	1520-FTR 244	1530-FS 249	3010-FTM 31	4072-3 185
1505-FTR 244	1520-M 258	1530-FS3 241	3010-GS 29	4072-4 186
1505-FTR3 244	1520-MM 250	1530-FS3 243	3010-GS 36	4084-3 185
1505-GS 240	1520-NL 254	1530-FS3 249	3010-NH 41	4084-4 186

4096-3	185	5037-2	215	6010	227	6205	226	8348-2	197
4096-4	186	5037-3	215	6020	227	6211	226	84-1830	197
4136-4	186	5037-A	216	6030	227	6212	226	84-1836	197
4136-5	186	5037-F	216	6035	227	6221	226	84-1848	197
4148-4	186	5040	216	6040	227	6222	226	84-1858	197
4148-5	186	5041	216	6041	227	6231	226	84-1872	197
4160-4	186	5044	216	6049	227	6232	226	84-2130	197
4160-5	186	5045	216	6050	228	7108	176	84-2136	197
4172-4	186	5047	217	6052	228	7109	176	84-2148	197
4172-5	187	5048	217	6054	229	7111	208	84-2158	197
4184-4	186	5049	218	6057	229	7115	208	84-2172	197
4184-5	187	5050	218	6061	230	7118	208	84-3033	198
4196-4	186	5051	218	6063	230	7119	208	84-3039	198
4196-5	187	5052	218	6066	230	7120	208	84-3051	198
4336-2	203	5053	219	6067	230	7124	230	84-3061	198
4348-2	203	5057	219	6068	230	7207	208	84-3075	198
4360-2	203	5058	217	6069	230	7208	209	84-7045	199
4372-2	203	5060-5	219	6070	228	7209	209	84-7051	199
4536-3	203	5060-6	219	6072	228	7210	209	84-7063	199
4548-3	203	5060-8	219	6073	228	7211	209	8436-2	197
4560-3	203	5065-8	219	6075	229	7247	209	8448-2	197
4848-4	203	5066-8	220	6078	229	7248	209	8448-3	198
4848-5	203	5067-6	220	6079	229	7336	199	8458-2	197
4860-4	203	5068-3	220	6082	229	7348	199	8458-3	198
4860-5	203	5069-2	220	6086	228	7360	199	8472-2	197
4872-4	204	5070	221	6088	228	7720	207	8472-3	198
4872-5	204	5072	221	6090	229	7722	207	8548-2	198
4884-4	204	5078	221	6091	229	7723	207	8558-2	198
4884-5	204	5079	222	6092	229	7724	207	8572-2	198
4896-4	204	5082	222	6093	229	7725	207	8636-2	198
4896-5	204	5083	222	6095	230	7727	207	8658-2	198
5010	217	5086	222	6096	230	7728	207	8748	182
5011	217	5136	199	6097	231	7729	207	8760	182
5014	217	5148	199	6098	231	7730	207	8848-5	187
5020	222	5160	199	6106	231	7731	207	8848-6	187
5021	223	5236	176	6107	232	7732	207	8860-5	187
5025	223	5248	176	6111	231	7733	207	8860-6	187
5026	223	5260	176	6117	232	7734	207	8872-5	187
5028	223	5448	181	6118	232	7735	207	8872-6	188
5029	223	5460	181	6119	232	7737	207	8884-5	187
5032-0	214	5748	181	6120	231	7738	207	8884-6	188
5032-1	214	5760	181	6121	231	7739	207	8896-5	187
5032-2	214	6001	226	6122	231	7740	207	8896-6	188
5032-3	214	6002	226	6123	231	7848	199	8936-7	177
5032-A	214	6003	226	6124	231	7936	176	8936-8	177
5032-F	214	6006	227	6126	232	7948	176	8948-7	177
5037-0	215	6007	227	6134	232	7960	176	8948-8	177
5037-1	215	6008	227	6135	232	8330-2	197	8960-7	177

INDEX

8960-8.....	177	A117.....	75	C12-W.....	28	E212.....	160	F60-H.....	190
9048-4.....	204	A117.....	114	C12-W.....	44	E219.....	156	F60-L.....	190
9048-5.....	204	A119.....	70	C13-E.....	35	E311.....	158	F70-A.....	189
9060-4.....	204	A119.....	109	C13-MM.....	37	E312.....	160	F70-G.....	205
9060-5.....	204	B110.....	50	C13-PC.....	47	E319.....	156	F70-R.....	206
9072-4.....	205	B111.....	53	C13-W.....	28	F111.....	83	F70-T.....	196
9072-5.....	205	B115.....	54	C13-W.....	44	F112.....	85	F70-X.....	206
9084-4.....	205	B116.....	55	C20-DH.....	40	F116.....	90	F72-L.....	190
9084-5.....	205	B117.....	56	C20-DL.....	40	F119.....	80	F87-A.....	189
9096-4.....	205	B119.....	52	C20-FTH.....	32	F211.....	83	F87-R.....	206
9096-5.....	205	B210.....	50	C20-FTL.....	33	F212.....	86	F87-T.....	196
9148.....	200	B211.....	53	C20-FTM.....	33	F216.....	90	F87-X.....	206
9160.....	200	B215.....	54	C20-NH.....	42	F219.....	81	G210.....	123
9536-3.....	188	B216.....	55	C20-NL.....	42	F311.....	84	G211.....	128
9536-4.....	188	B217.....	56	C20-X.....	45	F312.....	86	G212.....	129
9548-3.....	188	B219.....	52	C24-DH.....	40	F316.....	91	G215.....	130
9548-4.....	188	BB36.....	177	C24-DL.....	41	F319.....	81	G216.....	131
9560-3.....	188	BB48.....	177	C24-FTH.....	33	F32-W.....	190	G217.....	132
9560-4.....	188	BB60.....	177	C24-FTL.....	33	F36-E.....	189	G219.....	127
9572-3.....	188	BC36.....	178	C24-FTM.....	33	F36-F.....	190	G710.....	123
9572-4.....	189	BC36-5.....	178	C24-NH.....	43	F36-H.....	190	G711.....	128
9584-3.....	188	BC48.....	178	C24-NL.....	42	F36-L.....	190	G712.....	129
9584-4.....	189	BC48-5.....	178	C24-X.....	45	F38-A.....	189	G715.....	130
9596-3.....	188	BC60.....	178	C30-DH.....	41	F38-G.....	205	G716.....	131
9596-4.....	189	BC60-5.....	178	C30-DL.....	41	F38-R.....	206	G717.....	132
9636.....	177	BD36.....	178	C30-FTH.....	34	F38-T.....	196	G719.....	127
9648.....	177	BE36.....	178	C30-FTL.....	34	F38-X.....	206	H311.....	167
9660.....	177	BH36.....	179	C30-FTM.....	34	F411.....	84	H312.....	168
A011.....	70	BH48.....	179	C30-GS.....	29	F412.....	87	H316.....	169
A011.....	109	BH60.....	179	C30-GS.....	36	F416.....	91	H319.....	166
A012.....	71	BL36.....	179	C30-NH.....	43	F419.....	82	H32-W.....	181
A012.....	110	BL48.....	179	C30-NL.....	43	F42-A.....	189	H36-E.....	180
A015.....	72	BL60.....	179	C30-X.....	46	F42-G.....	205	H36-F.....	180
A015.....	111	C10-B.....	30	C410.....	97	F42-R.....	206	H36-H.....	180
A016.....	73	C10-E.....	35	C411.....	103	F42-T.....	196	H36-L.....	180
A016.....	112	C10-FTL.....	32	C416.....	105	F42-X.....	206	H38-A.....	179
A017.....	74	C10-H.....	29	C419.....	101	F48-L.....	190	H38-G.....	200
A017.....	113	C10-H.....	36	C510.....	97	F511.....	85	H38-R.....	200
A019.....	69	C10-MM.....	37	C511.....	103	F512.....	87	H38-T.....	195
A019.....	108	C10-PC.....	47	C516.....	105	F516.....	94	H38-X.....	201
A111.....	71	C10-Q.....	44	C519.....	101	F519.....	82	H411.....	167
A111.....	110	C10-W.....	28	E011.....	157	F56-A.....	189	H412.....	168
A112.....	72	C10-W.....	44	E012.....	159	F56-G.....	205	H416.....	169
A112.....	111	C12-E.....	35	E019.....	155	F56-R.....	206	H419.....	166
A115.....	73	C12-FTL.....	32	E111.....	157	F56-T.....	196	H42-A.....	179
A115.....	112	C12-H.....	29	E112.....	159	F56-W.....	190	H42-G.....	200
A116.....	74	C12-H.....	36	E119.....	155	F56-X.....	206	H42-R.....	200
A116.....	113	C12-PC.....	47	E211.....	158	F60-F.....	190	H42-T.....	195

H42-X	201	L56-A	183	SC36-4	192	X50-B	220	Z11-BW	64
H48-L	180	L56-G	201	SC36-5	192	X50-C	220	Z11-BW	147
H56-A	179	L56-R	202	SC48-4	192	X51-F	221	Z11-C4	104
H56-G	200	L56-T	195	SC48-5	192	Y10-C	207	Z11-C5	104
H56-R	200	L56-W	185	SC60-4	192	Y10-D	207	Z11-DW	64
H56-T	195	L56-X	202	SC60-5	192	Y10-F	207	Z11-DW	147
H56-X	201	L60-F	184	SC72-4	192	Y10-H	207	Z16-BW	67
H60-L	180	L60-H	184	SC72-5	193	Y10-J	207	Z16-BW	150
H70-A	179	L60-L	184	SC84-4	192	Y10-M	207	Z16-C4	106
H70-G	200	L70-A	183	SC84-5	193	Y11-C	207	Z16-C5	106
H70-R	200	L70-G	201	SC96-4	192	Y11-D	207	Z16-DW	67
H70-T	195	L70-R	202	SC96-5	193	Y11-E	207	Z16-DW	150
H70-X	201	L70-T	195	SD36-3	193	Y11-F	207	Z16-E0	161
H72-L	181	L70-X	202	SD60-3	193	Y11-J	207	Z16-E1	161
H87-A	179	L72-L	184	SE36-3	193	Y11-M	207	Z16-E2	162
H87-R	200	L87-A	183	SF36-3	193	Y12-C	207	Z16-E3	162
H87-T	195	L87-R	202	SF60-3	193	Y12-D	207	Z16-F1	94
H87-X	201	L87-T	196	SH36-3	194	Y12-F	207	Z16-F2	95
J48-X	210	L87-X	202	SH36-4	194	Y12-J	207	Z16-F3	95
K011	137	M011	119	SH48-3	194	Y12-M	207	Z16-F4	96
K012	138	M012	120	SH48-4	194	Y30-C	228	Z16-F5	96
K015	139	M016	121	SH60-3	194	Y31-A	230	Z16-G2	133
K016	140	M019	118	SH60-4	194	Z05-H	68	Z16-G7	133
K017	141	M111	119	SL36-3	194	Z05-H	107	Z16-H3	170
K019	136	M112	120	SL48-3	194	Z10-BW	60	Z16-H4	170
K111	137	M116	121	SL60-3	194	Z10-BW	143	Z16-M0	122
K112	138	M119	118	SL72-3	194	Z10-C4	100	Z16-M1	122
K115	139	RB48	182	W010	57	Z10-C5	100	Z19-BW	62
K116	140	RB60	182	W010	142	Z10-D	51	Z19-BW	145
K117	141	RC48	182	W011	63	Z10-DW	60	Z19-C4	102
K119	136	RC60	182	W011	146	Z10-DW	143	Z19-C5	102
K48-X	210	RD36	182	W012	65	Z10-E0	151	Z19-DW	62
L32-W	185	RH36	183	W012	148	Z10-E1	151	Z19-DW	145
L36-E	184	RH48	183	W016	66	Z10-E2	154	Z30-D	51
L36-F	184	RH60	183	W016	149	Z10-E3	154	Z30-H	69
L36-H	184	RL36	183	W019	61	Z10-F1	78	Z30-H	108
L36-L	184	SB36-3	191	W019	144	Z10-F2	78		
L38-A	183	SB36-4	191	W110	57	Z10-F3	79		
L38-G	201	SB48-3	191	W110	142	Z10-F4	79		
L38-R	202	SB48-4	191	W111	63	Z10-F5	80		
L38-T	195	SB60-3	191	W111	146	Z10-G2	126		
L38-X	202	SB60-4	191	W112	65	Z10-G7	126		
L42-A	183	SB72-3	191	W112	148	Z10-H	68		
L42-G	201	SB72-4	191	W116	66	Z10-H	107		
L42-R	202	SB84-3	191	W116	149	Z10-H3	163		
L42-T	195	SB84-4	191	W119	61	Z10-H4	163		
L42-X	202	SB96-3	191	W119	144	Z10-M0	115		
L48-L	184	SB96-4	191	X02-A	223	Z10-M1	115		

Maximize Cargo Capacity & Vehicle Performance With Contractor Grade, Organized Storage Systems

When you want the perfect upfit solution for your work vehicle, turn to Ranger Design. Crash-tested for toughness, Ranger's shelving and upfits will take whatever abuse you can dish out. Their unsurpassed craftsmanship, combined with ideal fit and finish, provide a quiet ride with no rattles.



CUSTOMER SERVICE

cs@rangerdesign.com
1-800-565-5321
rangerdesign.com



THE PERFECT FIT FOR YOUR TOUGHEST JOBS